

# ADKINS



Adkins DTF Inline Compact 600

Shaker Cure Unit

User Manual

Revision 1.0

<b>Introduction</b> .....	III
Caution .....	III
Requests .....	III
Product Appearance .....	III
Safety Precautions .....	IV
Symbols.....	IV-V
Unboxing and installation.....	VII-VIII
Working Environment .....	VIII
Place of installation .....	VIII
Temperature of working environment.....	VIII

## Chapter 1 - Before use

Part Names and Functions .....	1-1
Fronts.....	1-2
Rear side .....	1-3
Operating panel.....	1-4,5
Front & Rear Sensor .....	1-6
Powder box .....	1-6
Powder shaking blade .....	1-6
Lamp .....	1-6
Tension sensor .....	1-6

## Chapter 2 - Basic Operations

Workflow .....	2-2
Turning the Power On/OFF .....	2-3
Turning the power on .....	2-3
Turning the power o .....	2-3
Loading Media .....	2-4
Adjusting Sensor height.....	2-4
Loading roll media .....	2-4
Pouring power.....	2-5
Pouring power.....	2-5
Auto mode .....	2-5
Switch to auto mode .....	2-5
Conditions of AM.....	2-6
Stick the media .....	2-6
Link mode.....	2-7

## Chapter 3 - Maintenance Guidelines

Routine Maintenance .....	3-1
Before use.....	3-2
After use .....	3-2
Oven cleaning .....	3-2
filter box .....	3-2
Regularly replace the filter.....	3-3
How to replace filter box .....	3-3
Replacement cycle.....	3-3
Kind tips .....	3-3

## Chapter 4 - Warranty and Declaration

Warranty and Declaration .....	4-1
Design Change .....	4-2
Warranty .....	4-3
Declaration of Conformity.....	4-4
Installation Risk Assessment .....	4-5
Machine Risk Assessment .....	4-6
Parts Diagram .....	4-7,8

## Introduction

Thank you for purchasing the Adkins Inline Compact 600 Powder Shaker Cure Unit (hereafter called, "the machine").

Unauthorized reproduction of any portion of this document is strictly prohibited.

© Adkins

All Rights Reserved. Copyright

### Caution

Adkins is in no way liable for any damages whatsoever (including but not limited to lost profit, indirect damage, special damage, or other monetary damage) arising from using or inability to use the machine, except as provided in Adkins warranty provisions.

This applies even if Adkins has been informed of the possibility of such damages.

For example, we cannot be held liable for any loss of media or other materials from using the machine, nor are we liable for any indirect loss caused by printed materials.

Please note that we are not liable for any financial damage or lost profits resulting from the use of the machine, or for any claims from third parties.

### Requests

- This manual describes the operations and maintenance of the machine.
- Illustrations in the manual may be different from the appearance of some models.
- Read this manual carefully and make sure you understand it before use.
- Although every effort has been made to ensure the accuracy of the information in this manual, if you find any issues, contact your dealer.
- This manual is subject to change without notice for improvement.

### CE Statement

This equipment has been tested and found compliant with the requirements set forth in the declaration of conformity.

### Product Appearance

Please note that the descriptions of the product appearance in the operating manual are primarily based on the product you actually receive.

While ensuring the main functionality of the product remains unaffected, we continuously make subtle adjustments to the product appearance to achieve optimal design. These adjustments aim to enhance the overall look and feel of the product, providing you with an improved user experience.

In the case of significant changes, we will promptly notify you through the appropriate channels, ensuring that you stay informed about the latest product information.

### Machines Intended Use

Automatic powdering and fixation machine for direct-to-film transfer medias. Applying and melting the fixing powder to the ink on the transfer film to produce a garment decoration transfer.

The machine has built-in filtration and extraction for the removal of any by-products produced through the heating process. All components of the direct-to-film process is suitable for commercial use.

The machine is only for the intended use stated above.

Any misuse of the machine outside of being used for the powdering and fixation of direct to film powder or to direct to film medias is strictly ill-advised and not covered within the manufacturers warranty.

Inserting anything other than direct to film powder or direct to film media into the machine could lead to damage to the machine and injury to users of the machine.

### Airbourne Sound Emission

During use the A-Weighted Sound

Emission is 70db(A) or lower

**Do not** leave this machine unattended whilst in operation









**Do not** let unauthorised, unqualified or untrained people use machinery – never allow children to operate or help at the machine.

## Safety Precautions

### Symbols

In this manual, symbols indicate and explain precautions. The indicated symbol varies depending on the nature of the precaution. Make sure you understand the meaning of each symbol and use the machine safely and correctly.

### Example of symbols

	Meaning
	Failure to observe the instructions given with this symbol may result in death or serious injuries to personnel. Be sure to read the precaution carefully and use the machine
	Failure to observe the instructions given with this symbol may result in injury to personnel or damage to property.
	Important notes regarding use of the machine are given with this symbol. Use as reference information.
	Useful information is given with this symbol. Use as reference information.
	Indicates the corresponding page for related information.
	Indicates a precaution requiring attention (including cases of danger or warnings). Specific precautions are shown in the figure.
	Indicates a prohibited action. Specifically prohibited actions are shown in the figure.
	Indicates an action that must be taken or instructions that must be followed. Specific instructions are shown in the figure.

### Warnings and precautions in use

#### **WARNING**



The set of power cables provided with the machine is for use only with the machine and cannot be used with other electrical devices. Do not use any power cables other than the ones provided with the machine. Failure to observe these instructions may result in fire or electric shock.

- Do not attempt to modify the cable, and avoid damaging or breaking it. Placing heavy objects on, heating, or pulling the cable may damage it, which may result in fire or electric shock.
- Avoid use in humid places. Additionally, do not pour water on the machine. Failure to observe these instructions may result in fire, electric shock, or failure.
- Use of the machine under an abnormal condition, as when it is emitting smoke or fumes, may result in fire or electric shock. Turn off the power switch immediately, and then be sure to unplug the machine from the outlet. Once you have confirmed that smoke is no longer being emitted, request repair from your dealer. Never attempt to repair the machine yourself. Doing so is hazardous.

Never disassemble or modify the machine. Failure to observe these instructions may result in electric shock or failure.

- Do not use extension cords. Failure to observe these instructions may result in fire or electric shock.
- Keep foreign objects such as pieces of metal away from the power plug prongs. Failure to observe these instructions may result in fire or electric shock.
- Do not overload electrical outlets by using too many pieces of equipment. Failure to observe these instructions may result in fire or electric shock.
- If the power cable is damaged or the core wire is exposed or broken, ask your service representative to replace it. Using it as is may result in fire or electric shock.

Do not handle the power plug with wet hands. Failure to observe these instructions may result in electric shock.

- Always hold the power cable by the plug when unplugging the machine. Do not unplug by holding the power cable. Failure to observe these instructions may damage the cable or result in fire or electric shock.

Do not use a voltage other than the indicated voltage. Failure to observe these instructions may result in fire or electric shock.

- Do not use a power frequency other than the indicated frequency. Failure to observe these instructions may result in fire or electric shock.

If metal, water, liquid, or other foreign objects enter the machine, turn it off immediately. After that, be sure to unplug the machine and contact your service representative. Using it as is may result in fire or electric shock.

- If ink leaks, turn off the main power switch, unplug the machine, and contact your dealer, service office, or call center.

Keep the heater on the media transport surface free of dust and debris. Failure to observe these instructions may result in sparks or fires.

- Keep children away from this machine.



Do not use a flammable spray or solvent inside or around the machine. Failure to observe these instructions may result in fire or electric shock from ignition.

- Do not place vases, pot plants, cups, cosmetics, containers of chemicals or water, or small metal objects on top of the machine. Liquid or foreign objects may get inside the machine, leading to fire or electric shock.

## Precautions in use

### CAUTION

#### Handling of the power cable



- Plug into a polarized electrical outlet.
- Always plug the power cable into an outlet near the machine, and make sure the power cable can be easily unplugged.
- Regularly (at least once a year) unplug the cable and remove any dust on or near the power plug. Failure to remove dust may result in fire.
- Do not use a voltage other than the indicated voltage.
- Before plugging in the machine, check the outlet supply voltage and circuit breaker capacity. Plug each cable into a power source with an independent breaker. If you plug more than one power cable into outlets that share the same circuit breaker, it may trip the



#### Notes on maintenance



- Pay close attention to ventilation and be sure to wear safety glasses, gloves, and a mask when dealing with unused hot melt powder, airborne particles may enter the eyes or mouth. Please take precautions.



#### Moving part precaution



- Keep fingers and other body parts away from hazardous moving parts.
- Do not touch the dusting roller when it is rolling. Failure to observe these instructions may result in finger injury such as torn skin or fingernails.
- Keep your head and hands away from moving parts during operation. Failure to observe these instructions may result in injury such as your hair becoming caught in the machine.
- Wear suitable clothes. (Do not wear loose-fitting clothes or accessories.) Keep long hair bound.



### CAUTION

#### Heater



- Do not pour liquid on the media transport surface. Failure to observe these instructions may result in heater failure or sparks.
- Do not touch the media transport surface with bare hands while the heater is hot. Failure to observe these instructions may result in burns.

## Precautions and notes

### WARNING

#### Consumable items



- Machine consumables, including hot melt powder and transfer film.
- The machine's safety level is based on the use of Adkins recommended transfer film. To ensure operational safety, please use the transfer film recommended by Adkins.
- If hot melt powder is brought from a cold place to a warm place, please let it sit at room temperature for at least three hours before use (refer to product info for full details).
- Do not leave consumables exposed to the air for an extended period; if left open for a long time, they may not transfer properly. If not in use, seal and store them.
- Store consumables in a cool, dark place.
- Keep consumables out of reach of children.
- Once consumable packaging is opened, please use it within half a month. After a certain period of time, the transfer quality may decline. Refer to specific product details.
- Please hand over unused consumables to your dealer or service representative. If handling them yourself, comply with the requirements of industrial waste disposal facilities and local regulations.

#### Components requiring periodic replacement



- Some parts of the machine require regular replacement.

#### Machine disposal



- Contact your dealer or service representative for assistance when disposing of the machine. If you will dispose it by yourself, request assistance from an industrial waste disposer.

## WARNING

### Notes on maintenance

- Use in a room with as little dust as possible.
- Use in a room with as much ventilation as possible.
- **Important:** Regularly wipe the oil tank to keep it clean and prevent oil accumulation.
- Store transfer film in a bag. Wiping off dust accumulated on the media will adversely affect the media due to static electricity.
- When leaving the workshop after working hours, do not leave any media on the roll hanger. Dust will adhere to the media.

## WARNING

### Handling of Media

- Use recommended media. Please use the media recommended by Adkins to ensure reliable, high-quality transfers.
- Be aware of media expansion and contraction. Do not use media that has just been opened. The media may expand or contract depending on the room temperature and humidity. Open the package and allow it to adjust to the place of use for at least 30 minutes before loading it in the machine.
- Do not use curled media. Not only does this cause media jamming, but it also affects transfer quality. Straighten any media that is significantly curled before use. When rolling up regular-sized coated media for storage, make sure the coated side is facing outward.
- Set the heater temperature to suit media characteristics.
- Do not leave media loaded over extended periods with the heater on.
- With some types of media, under high temperature and humidity, it may affect the transfer. Be careful about where media is stored.
- With some types of media, if the media is left exposed to air, the ink-receiving layer may change, causing image defects such as blurred colors and bleeding.

## Warning signs and Mandatory signs

### Warning Signs



“Warning; electricity” and it is used to warn people about the risk of coming into contact with electricity (e.g. electric shock, electrocution hazard, hazardous voltage).



“Hot Surface” and it is used to warn people to take care to avoid coming into contact with a hot surface.



“Crushing Hazard” and it is used to warn people to take care to avoid coming into contact with moving parts during operation.

## Installation precautions

places exposed to direct sunlight

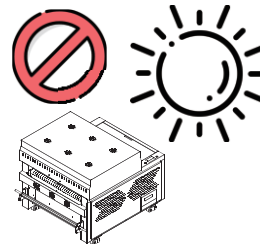

places with uneven surfaces

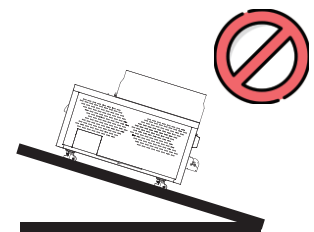

places where vibration is generated

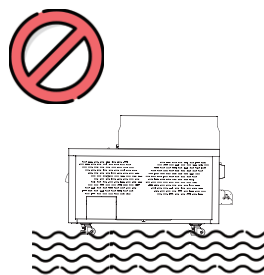

Places directly exposed to air conditioning

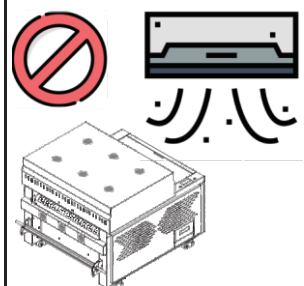

Places subject to significant changes in temperature or humidity

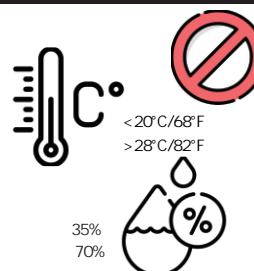

Places where open flames are present

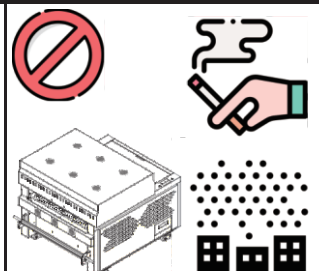

## Unboxing and installation

### Unboxing

Before installing the machine, ensure that the required amount of space is available in the place under consideration. The place of installation must have enough space for the machine as well as transferring tasks. See overleaf.

When moving the boxed item, only insert and lift where the markings are instructing.



Place the box in a position that is flat and level, and that you have sufficient space to unbox and remove the machine from the pallet.

Remove the securing transport screws. It is recommended that 4 people lift the sides and lid upwards and over the machine, taking care not to damaged/scratch the outer surfaces.

The protective wrapper can be removed from the machine.

Within the packaging are two ramps which can be used to allow the machine to be maneuvered off the pallet. It is recommended that 4 people maneuver the machine off the pallet and into position.

### Installation

The heater side panels are fixed by screws for transportation and need to be removed, and the filter door connection checked.

- 1 Remove the screw marked (A) that is securing the side panel. Once the screw is removed, gently lift the side panel (C) upwards to remove the panel



- 2 Proceed to remove the side panel from the opposite side, by removing the screw (B).



- 3 Once both sides are removed, remove the two screws that are holding the hood cover in place. There is one screw either side located as below.





## Unboxing and installation

### Installation

- 4 Position the machine in front of the printer to be used. The printer and machine has to be perfectly aligned for the film to run true.

If there is any mis-alignment the media can move or track off while in operation causing issues.

Use a tape measure to check that the front of the machine is aligned to your printer.

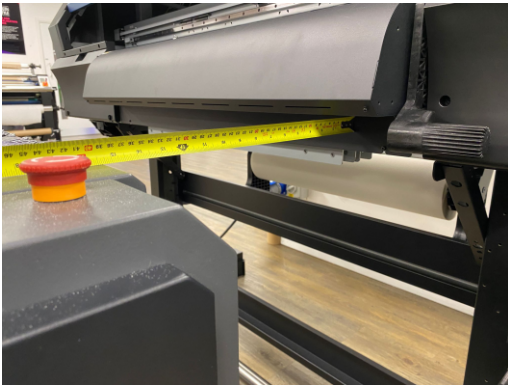

- 5 Using a spirit level, if possible (with adjustable feet) ensure the printer is level first. Then level the machine by lowering the rubber feet, via the red adjuster cog.

- 6 Connect the plug to a suitable plug socket (do not use an extension lead) and switch on via the green on/off button. If the system does not turn on, make sure that the emergency stop is not engaged.

Ensure the power lead is not going to come in to contact with any moving parts or any heat source and does not constitute a trip hazard.

## Working Environment

### Places of installation

Before installing the machine, ensure that the required amount of space is available in the place under consideration. The place of installation must have enough space for the machine as well as transferring tasks.

Width	Depth	Height	Total Weight
980mm	1140mm	1430mm	192kg

### Top View

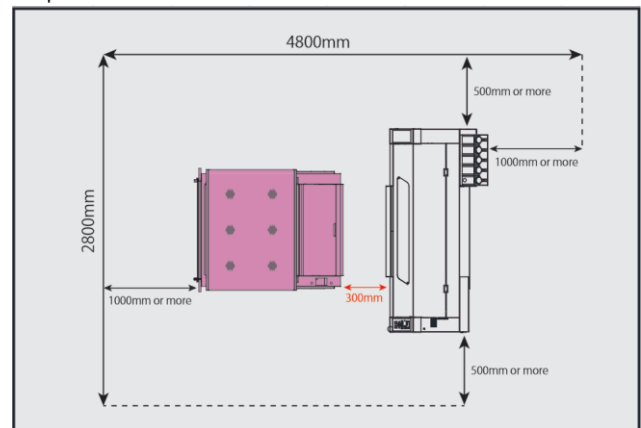

### Side View

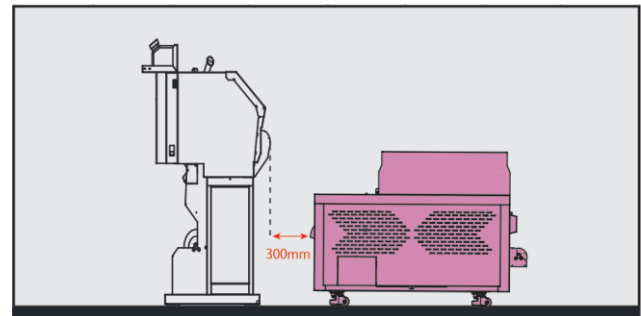

### Temperature of working environment

To ensure reliable transferring, use the machine in an environment of 20-28°C.

### Airbourne Sound Emission

During use the A-Weighted Sound Emission is 70db(A) or lower

# Chapter 1

## Before Use



### About this chapter

This chapter describes information to know before use, such as part names and installation instructions.

Part Names and Functions .....	1-1
Front .....	1-2
Rear .....	1-3
Operating panel .....	1-4,5
Front & Rear Sensor .....	1-6
Powder box .....	1-6
Powder shaking blade .....	1-6
Lamp .....	1-6
Tension sensor .....	1-6

# Part Names and Functions

## Front

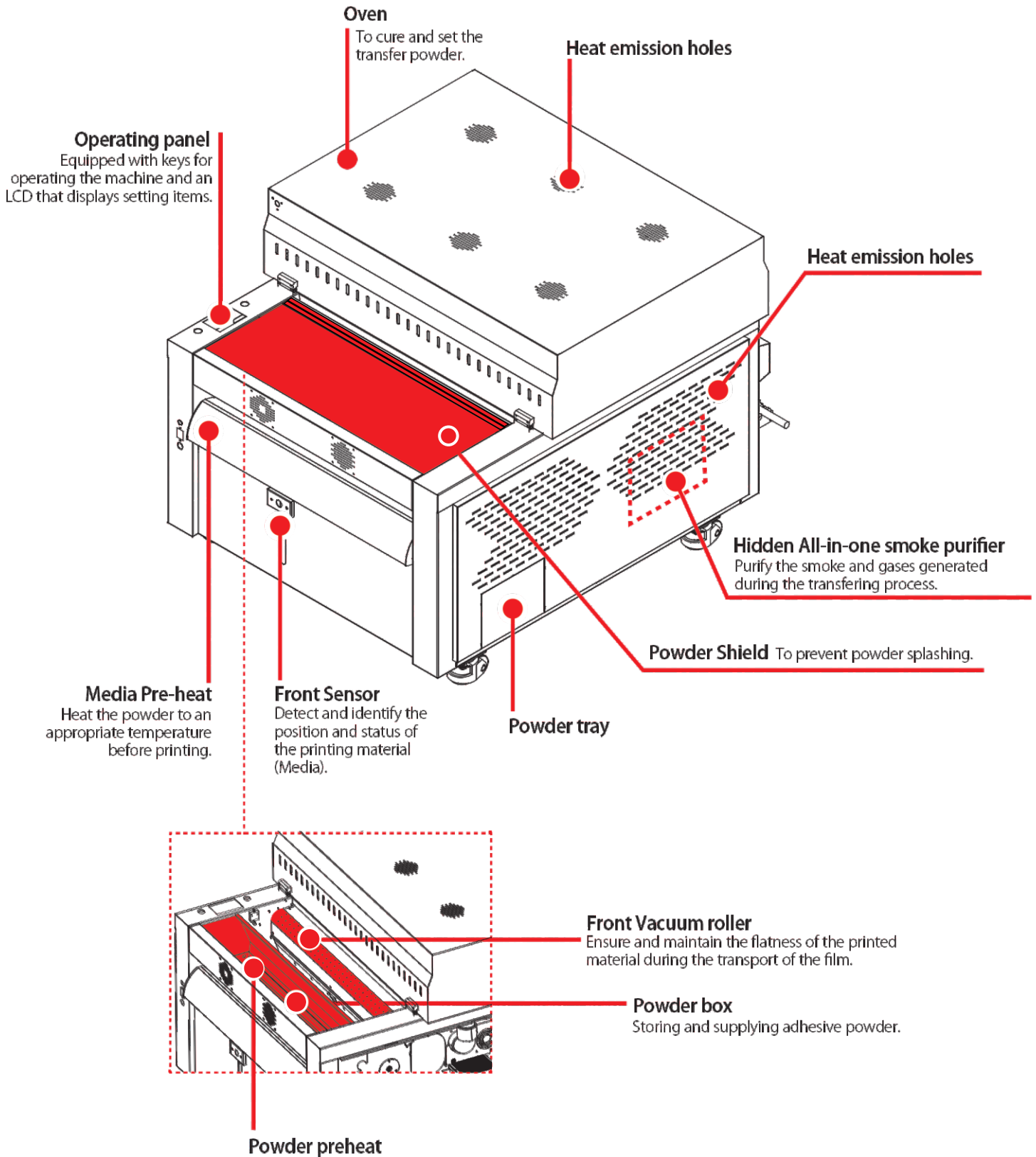

## Rear

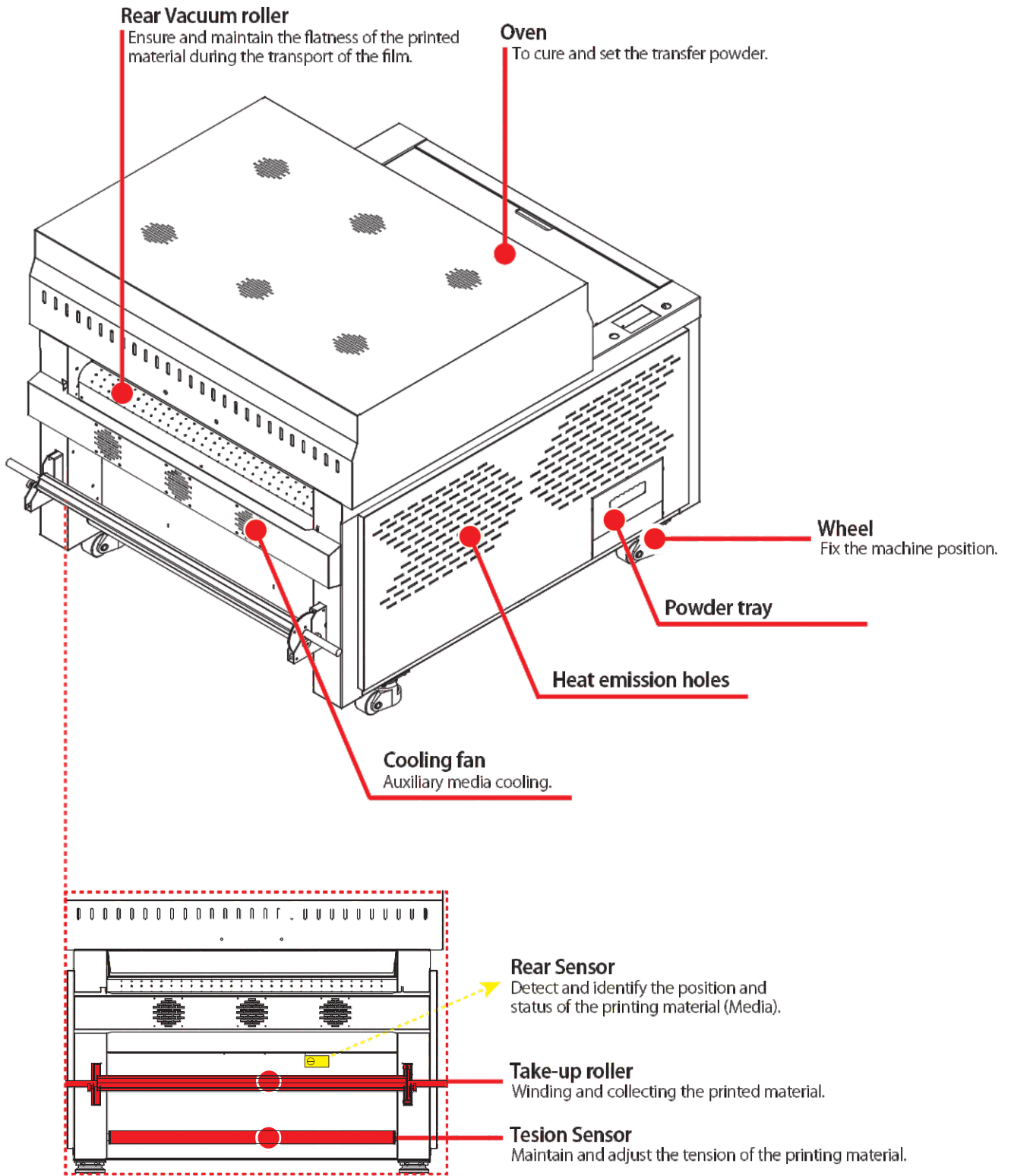

## Operating Panel

Use the operating panel to specify print settings or operate the machine.

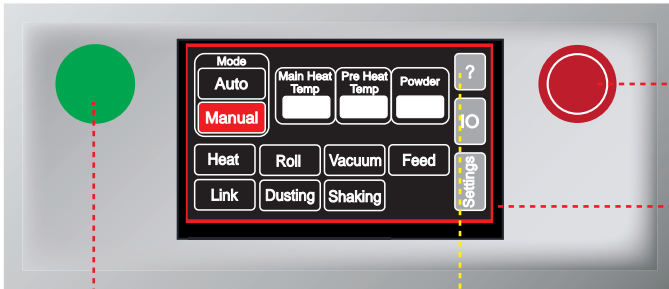

**Main Power**  
Press to turn on / turn off the machine

**Information**  
The detailed introduction of each interface

**Emergency Stop**  
Press to quickly and immediately halt the operation of the machine in case of an emergency or potential hazard

**Intelligent touch display**  
Shows the following items:  
Seven functions  
Auto/manual mode  
Heat temperature (flashes with target temp whilst heating)  
Pre temperature (flashes with target temp whilst heating)  
Powder- Powder weight  
(IO) Input/Output setting  
Setting  
Main menu

## 1. Function introduction

Icon	Details
	<p>"LINK mode", <b>can only be activated in the machine's automatic mode.</b> Link mode turns the film sensor off and instructs the machine to pull the film through the dryer, whether or not there is film in front of the sensor. This is used at the end of a job.</p>
	To activate the machine's heating function.
	To initiate the powder box roller to dust powder on to the film.
	To start the operation/suction of the Vacuum roller.
	To initiate the take up motor and tension system.
	To activate the powder shaking function (to remove excess powder from film).
	To start the vacuum movement, initiating the paper feeding movement of the machine when in manual and partial auto mode.

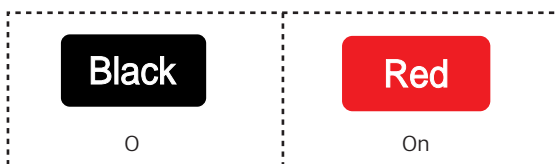

## 2. Temperature

Icon	Details
Heat Temp	Show the current temperature of oven (flashes with target temp whilst heating).
Pre Temp	Show the current temperature of pre-heater (flashes with target temp whilst heating).
Powder	Show the current capacity of powder in the weight sensor, display showing a minimum value of 0 and a maximum value of 100 (0-100).

## 3. Settings



The parameters may require adjusting depending on the film, powder and print settings you use. Suggested initial settings given below as a guideline:

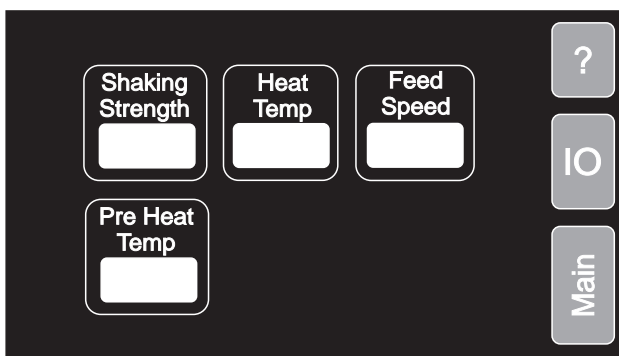

- 1) Shaking Strength  
Frequency of the powder blade intensity.
- 2) Heat Temperature  
Operating/target temperature of the oven.
- 3) Feed Speed  
The speed of media feeding when in manual mode and partial auto mode.
- 4) Pre Temperature  
Operating temperature of the pre heating area.

## 4. Input/output settings

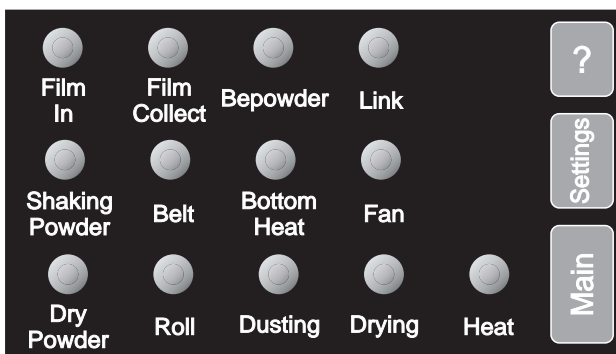

The displayed parameters here correspond to the working status of their respective names and do not support manual adjustment.

Icon color varies depending on the function working status.  
Red: Working status not met/sensed  
Grey: Working status met/sensed

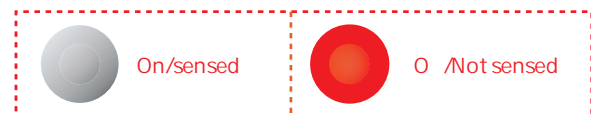

To determine the specific working status, please contact your dealer or press the "?" button to know more.

## 5. Auto/Manual mode

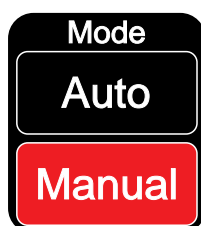

Switch to choose Auto mode or Manual mode of the machine.



Auto mode:

When the powder capacity value reaches **approx 80** and the oven temperature conditions have reached the specified temperature, and the Front sensor has sensed the film the machine can initiate the automatic transfer mode, allowing one person to operate multiple machines simultaneously.

The machine will automatically feed the media at the speed of the printer, cure and take up the film on to the take up core.

Manual mode:

In manual mode, the machine allows adjustment of various parameters, enabling real-time monitoring and adjustment of machine operations giving full manual control.

## Front & Rear Sensor

The front sensor is used to detect whether the machine has fed in media. The machine is equipped with one front sensor, located beneath the media pre-heat.

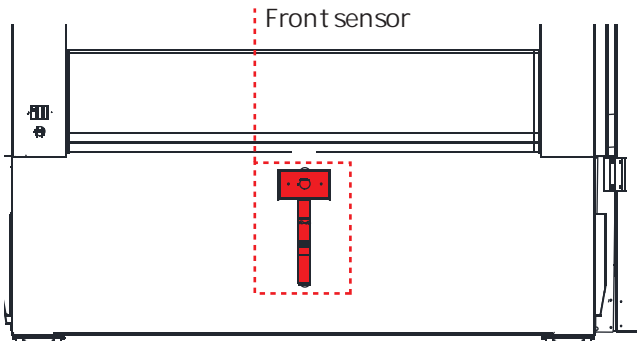

The front sensor has adjustable height levels, allowing users to adjust it to the appropriate position based on their needs.

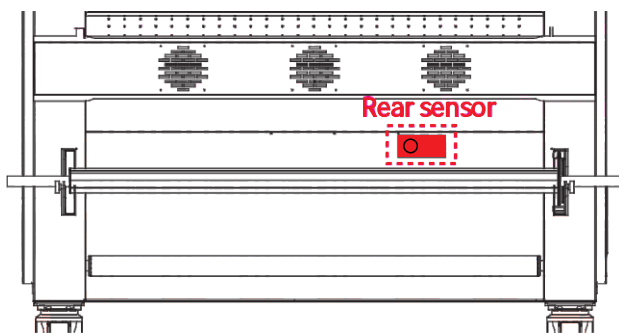

After the transfer film is finished baking, it will exit the oven. The rear sensor is used to detect whether the transfer film has completed baking and emerged from the back.

## Powder Box

The powder box's main functions include Powder Storage, powder supply and convenient powder replacement, ensuring a continuous supply of powder and high-quality printing results.

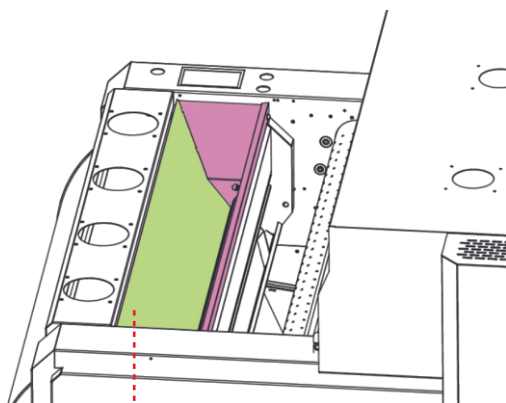

### Powder preheat

Its purpose is to maintain a high level of dryness for the hot-melt powder inside the box, preventing it from absorbing moisture.

## Heat Lamps

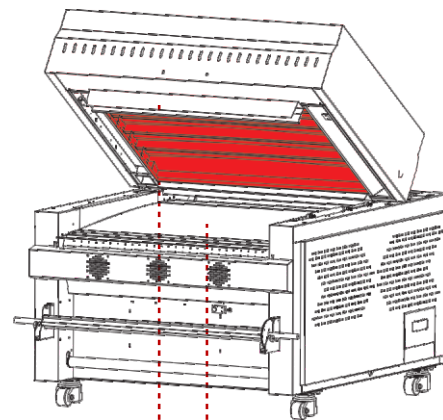

The upper and lower double rows of high-efficiency heating lamps (lower row is under the feeding belt)

Combined with our unique intelligent heating solution, which offers efficient power consumption.

## Tension Sensor

The tension sensor is used to maintain and adjust the tension of the printing material, besides it helps maintain print quality, facilitate powder transfer, and ensure accurate printing positioning by adjusting the tension of the printing material.

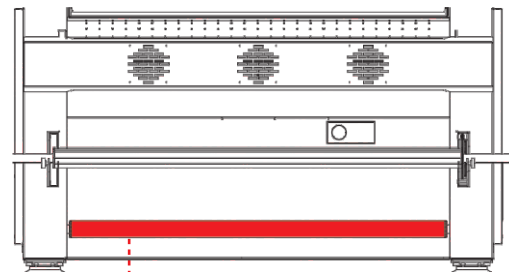

Tension sensor  
Located beneath the take-up roller.

## Powder Shaking Blades

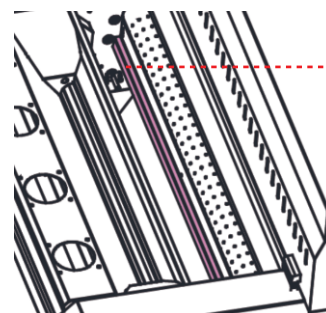

### Powder shaking blade

Contributing to the uniform distribution of transfer powder through vibrational motion, thereby ensuring high-quality and consistent printing results, located beneath the vacuum roller.

## Dual Vacuum Rollers

Through dual suction from the front and back, the paper feeding accuracy is ensured during the film transportation process, allowing it to better adhere to the conveyor belt. This ensures even baking of the transfer film.

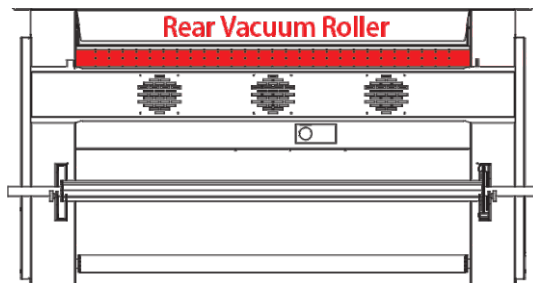
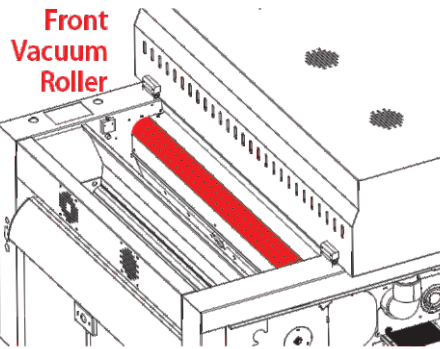

Once the film is detected by the rear sensor, the front vacuum roller will stop suction but continue to transport the film, while the rear vacuum roller will maintain both suction and transport functions.

## Powder Shield

**Powder Shield**

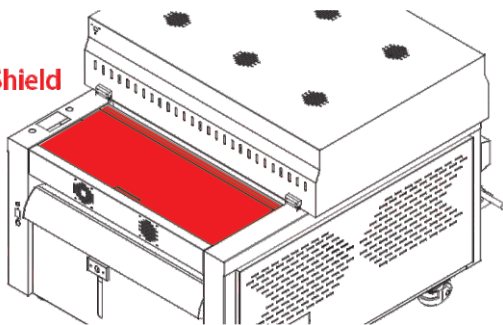

The powder shield's function is to prevent powder from splashing. If it is opened while the machine is running, the powder shaking function will stop. Once it is closed, the powder shaking function will resume.



# Chapter 2

## Basic operation



### About this chapter

This chapter describes information about basic operation, such as how to load printing media, how to use auto mode and link mode correctly.

Workflow .....	2-2	Auto mode .....	2-5
Turning the Power On/OFF.....	2-3	Switch to auto mode.....	2-5
Turning the power on.....	2-3	Conditions of auto mode.....	2-5,6
Turning the power o .....	2-3	Stick the media.....	2-6
Emergency stop.....	2-3	Link mode .....	2-7
Loading Media .....	2-4		
Adjusting Sensor height.....	2-4		
Loading roll media.....	2-4		
Pouring power.....	2-5		
Pouring power.....	2-5		

## Workflow

1

Turning the power on/o

See [ turning the power on/o ]  
Page 2-3.

2

Loading media

See [ Loading power ] Page 2-4.

3

Pouring powder

See [ Loading powder ] Page 2-5.

4

Auto mode

See [Auto mode ] Page 2-5,2-6.

5

Link mode

See [Auto mode ] Page 2-7.



Please notice

The machine used to demonstrate the workflow in this section differs from the actual model, but the overall workflow sequence remains the same.

## Turning the power on/o

### Turning the power on

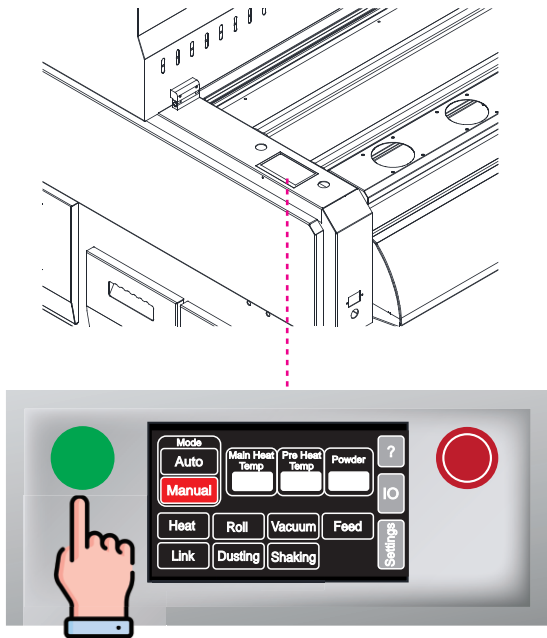

Press to turn on the machine

### Turning the power o

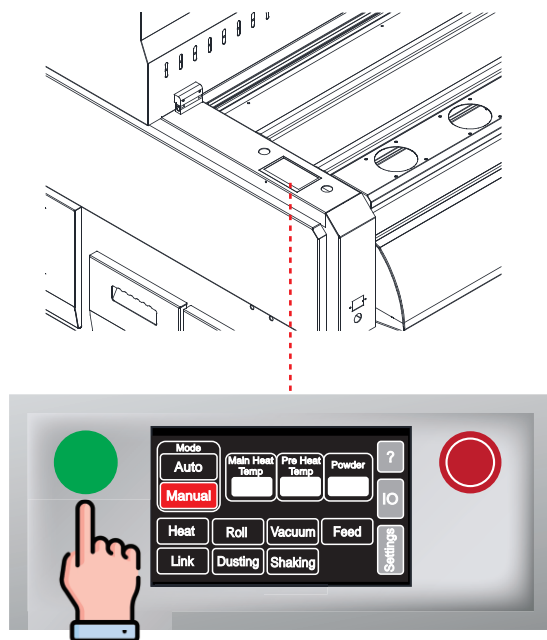

Press to turn o the machine



Please ensure that the machine completes the transfer operation before turning o the power

### Emergency stop

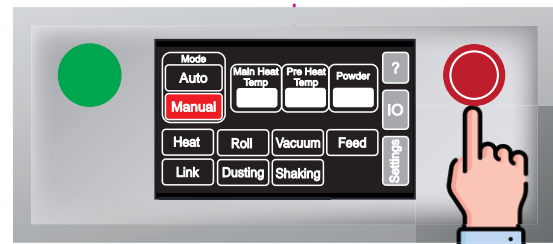
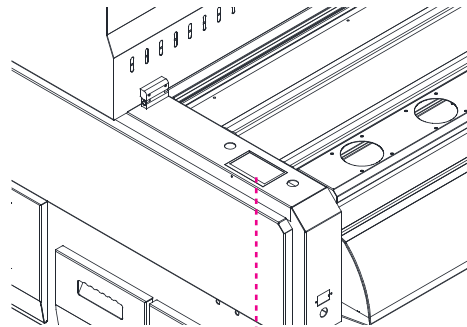

- 1) Press to activate
- 2) Rotate the button to the right to exit the emergency stop state



### WARNING

#### Emergency Stop



Emergency stop can be activated only in the following situations:

- Emergency Scenarios: In case of emergencies or potential hazards, the emergency stop button or switch is used to quickly initiate the emergency stop. This rapidly halts all movements of the machine to prevent injuries or equipment damage.
- Loss of Control: If the operator loses control of the machine and is unable to handle unforeseen circumstances, the emergency stop is employed to swiftly halt the machine operations.
- Equipment Malfunction: When there is a malfunction or abnormal operation of the equipment, the emergency stop helps prevent further damage and protects both operators and the equipment.
- Safety Checks: During maintenance or safety checks, it may be necessary to activate the emergency stop to ensure the safety of personnel.



It's important to note that the emergency stop is intended for responding to urgent situations or ensuring safety, so it should be used sparingly under normal circumstances. After activating the emergency stop, a proper inspection and maintenance of the machine are usually required to ensure its safety and normal operation.

## Loading Media

### Adjusting the sensor height

**1** Adjusting the sensor height

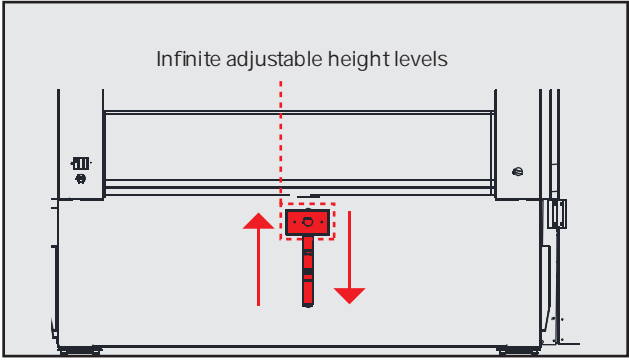

### Loading the film/media

**1** Wait until the media is long enough  
The media length should generally reach close to the ground see below.

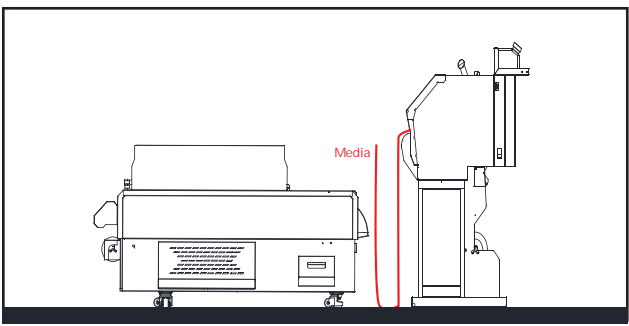

**2** Feed the media into the shaker  
The entrance is as shown in the diagram, above the preheating plate.

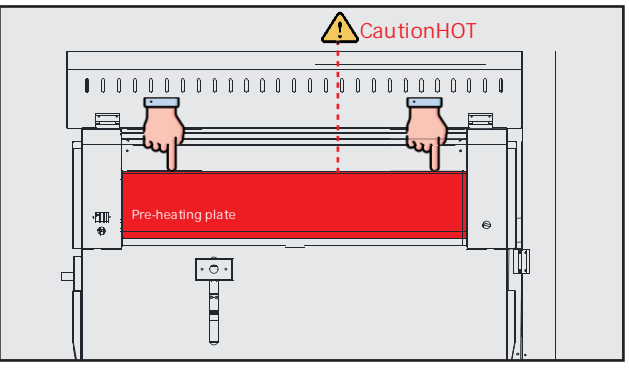

### Loading the film/media

**3** Feed the media through to the vacuum roller

Ensure that the media is placed over the vacuum roller, keeping it fed straight, and hold in place.

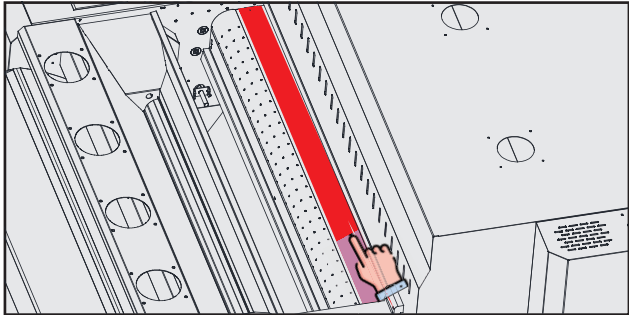

**4** Turn on the Vacuum function  
Activate the vacuum roller to hold the film in place.

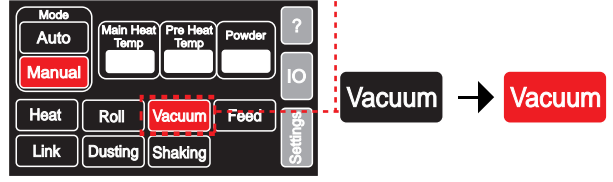
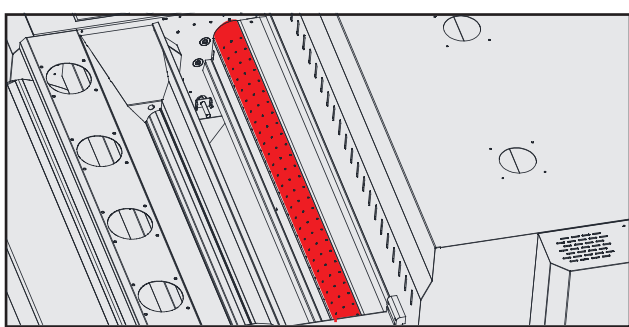

**5** Adjust the position of the powder holders  
With the media holders pushed close to the media, this ensures Minimal powder will fall outside or on the film, reducing the interval for replenishing powder.

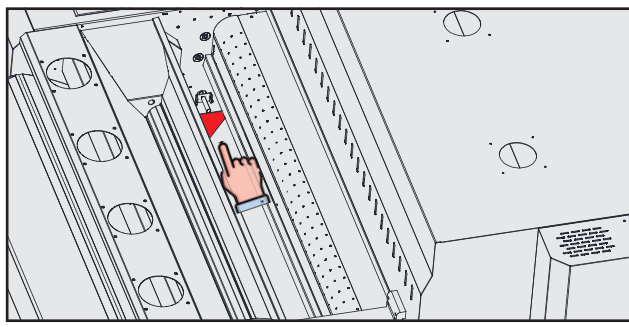

## Pouring powder

### Pouring powder

- 1 Adding powder in to the powder box

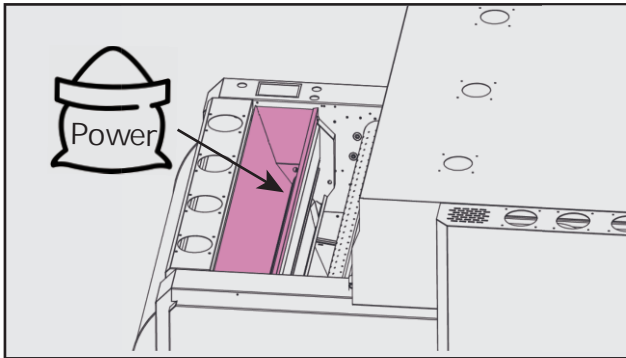

- 2 Powder tray  
Opened adhesive powder can be stored in the powder tray to facilitate easy extraction for the next powder addition.

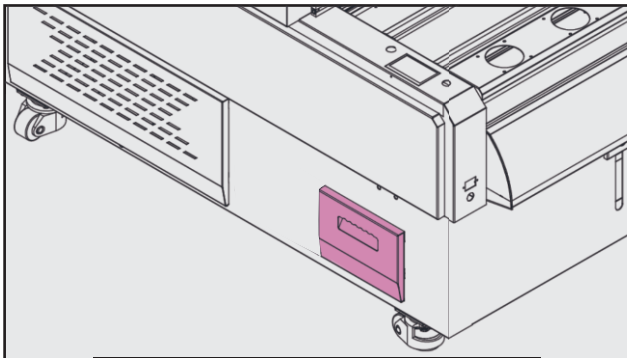

## Auto mode

### Switch to Auto Mode

- 1 Turn the "Heat" function on. (15 minutes of preheating is recommended before moving to step 2).

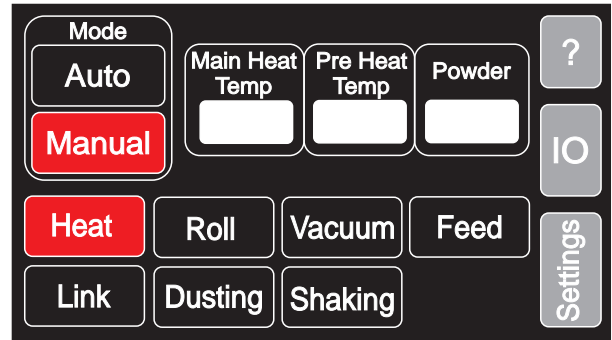

- 2 Switch the auto function on

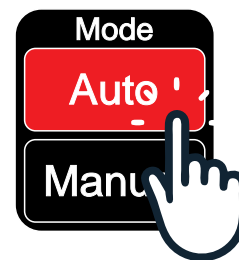

### Conditions of Auto Mode

- ! For Auto Mode to function the following conditions are required.

- 1 The machine needs to sense film is present (at the front film sensor)

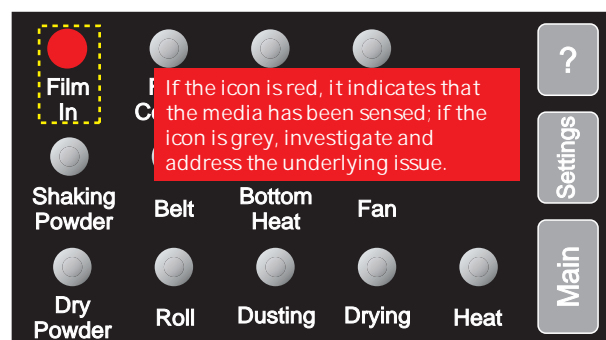

## Conditions of Auto Mode

- The powder weight sensor has reached approx 80% or more

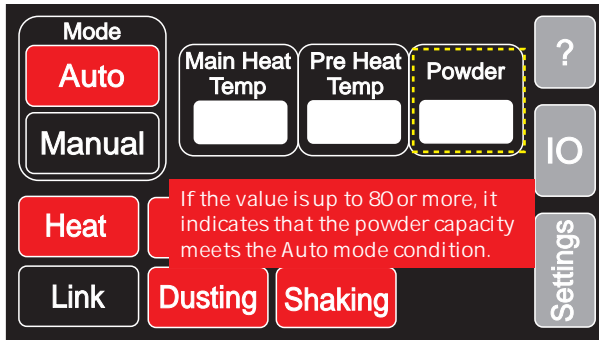

- The temperature has reached the target/set temperature

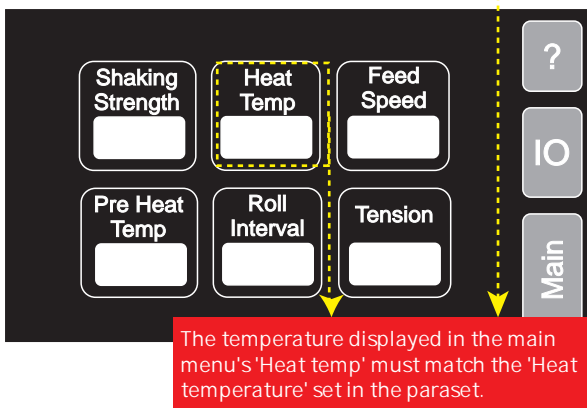
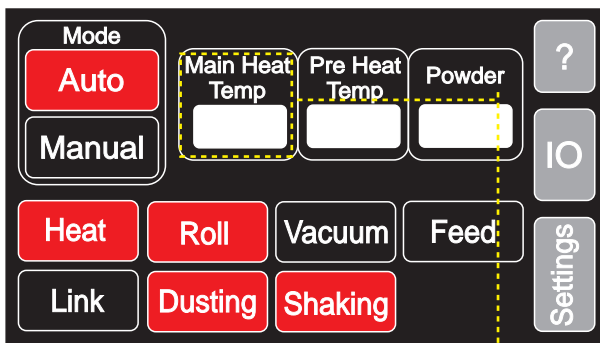

- The machine is now in partial auto mode

After the machine meets the above three conditions, it enters the semi-automatic mode status, allowing for the next step in the operation.

## Loading film/media to take up

- Wait for the film to pass through the oven.

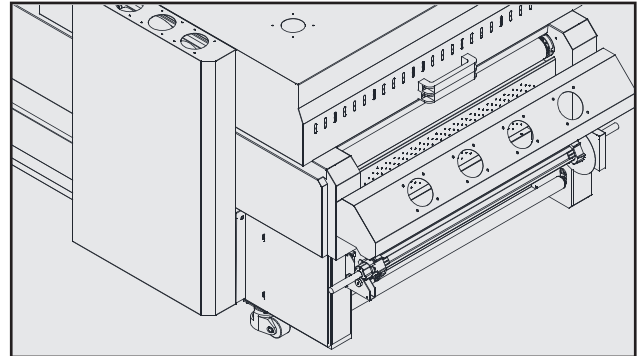

- Allow enough slack on the film

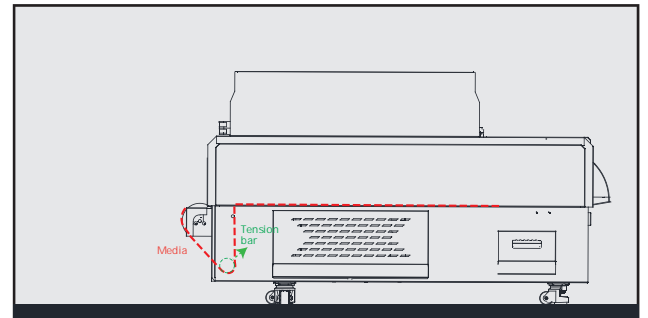

- Attach to the a cardboard take up core.

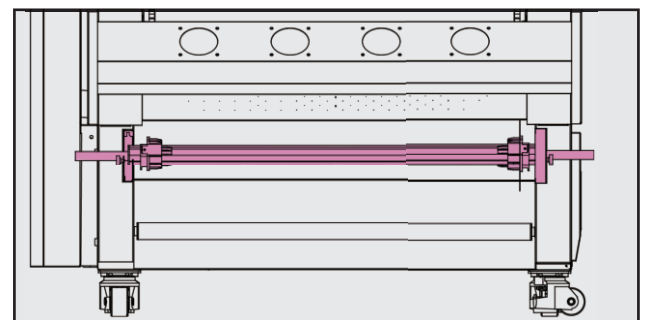

- The machine is now in full Auto Mode.

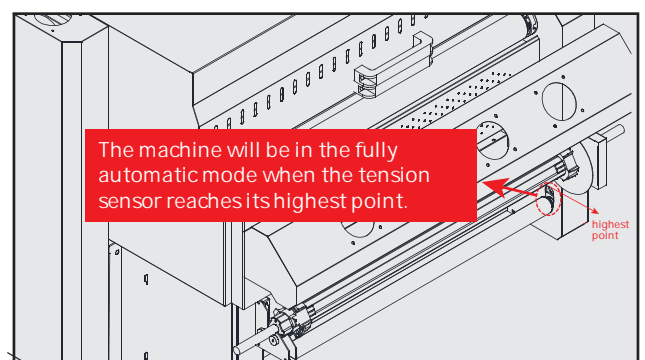

## When the machine is in full Automatic Mode



After the full automatic mode is activated, the feeding belt starts moving backward, the vacuum roller stops operating, and the tension take-up system gradually pulls and tightens the media through the oven.

The belt moving in reverse ensures no wrinkles or creases appear in the film.

The vacuum roller operates intermittently allowing for the film to self align and ensure straight feeding.

## Link mode

### Link mode



Link mode can only be activated upon completion of the transfer operation in auto mode.

1

Turn on Link Mode

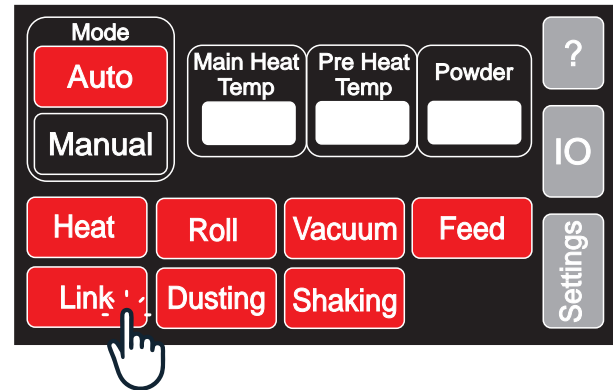

2

After the print has finished roll off 500mm then cut the film.

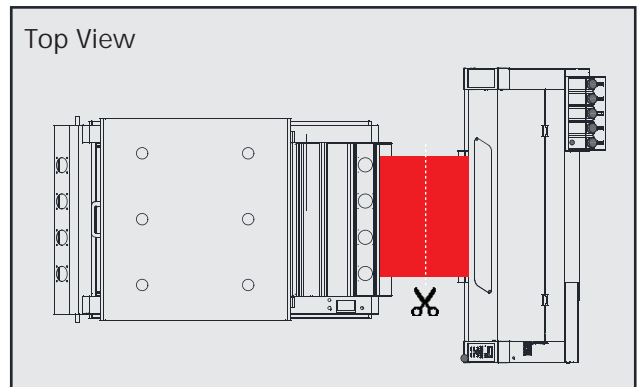

3

Allow the film to feed through and cure



After initiating the link mode, the machine will automatically complete the final heating work, ensuring the last media in the oven is fully baked until there is no media left inside.

The system continues to pull the media through as the front sensor is deactivated in link mode.

# Chapter 3 Maintenance Guidelines



## About this chapter

This chapter is about some daily maintenance guidelines of the machine, properly maintaining the machine can extend its lifespan.

Routine Maintenance .....	3-1
Before use.....	3-2
After use .....	3-2
Oven cleaning .....	3-2
Replace the filter regularly.....	3-3
How to replace the filter box .....	3-3
Replacement cycle .....	3-3
Tips .....	3-3





Due to the large amount of glycerin in the composition of DTF white ink, it is normal for oil and water condensation to appear on the metal surface after the machine is used. In order to prevent condensation from accumulating on the machine during long-term use, please follow the maintenance instructions below.

## Before use

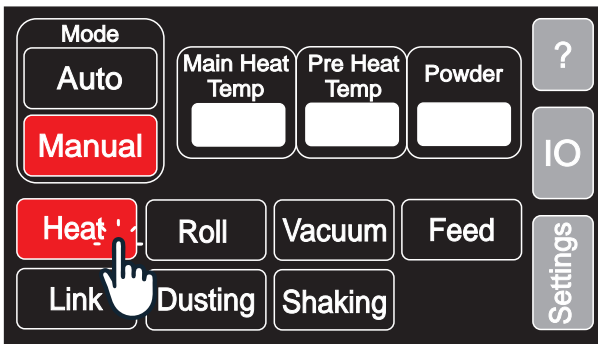

It is recommended to turn on the Heat function for 15 min before starting each work session to enhance the curing effectiveness.

## After use

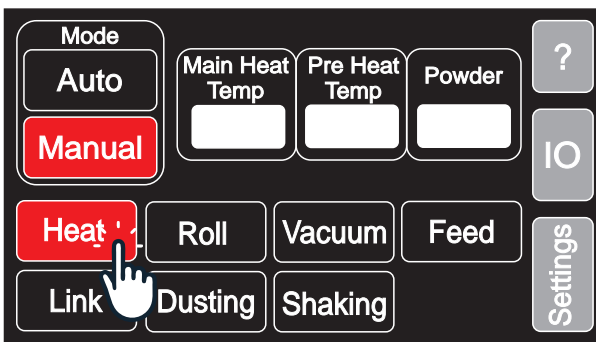

After each day's work, be sure to activate the Heat function for 15 minutes to reduce water and oil condensation.

## Oven cleaning

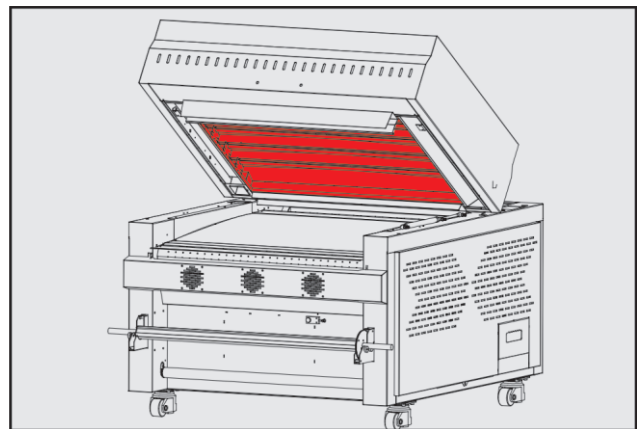
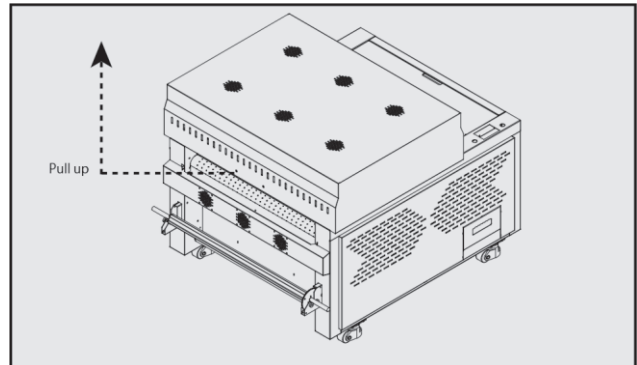

Open the machine oven and wipe off the oil inside the oil guide groove, and all internal surfaces.



Due to the build up of glycerin/oil which comes from DTF ink it is extremely important that time is taken at each day to thoroughly clean excess oil from all surfaces (including inside the lid/hood).

The oil residue cannot be fully eradicated due to the oil particles becoming airborne, which forms condensation on various parts of the machine.

Failure to clean the surfaces daily can result in oil build up and leakages from various parts of the system and can contribute possibly faults.

## Replace the filter regularly

Replace the filter cartridge regularly according to the working condition, refer to the filter cartridge replacement guideline (as below):

### 1. How to replace the filter box



**1** Open the Smoke purifier.

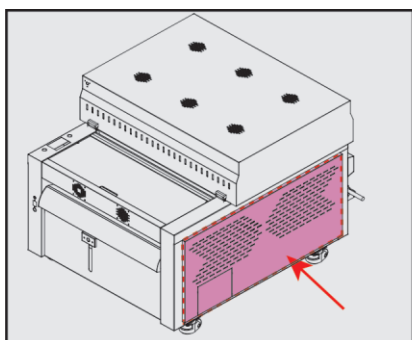

**2** Loosen the screws securing the filter, box panel then to reveal the filters

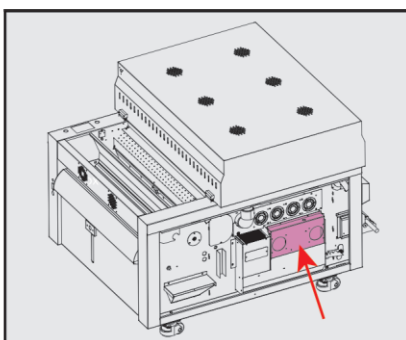

**3** Pull the old filters out and install the new filters (Carbon at the bottom).

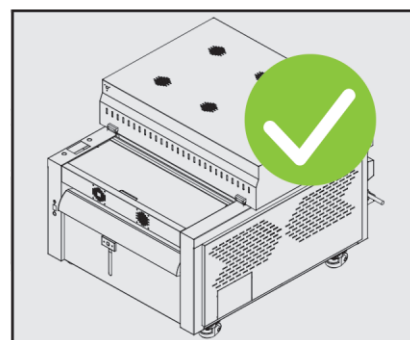

### 2. Replacement cycle

Use status	Suggested replacement cycle
High frequency use	1.5 months
Low frequency use	3 months
If there is smoke	Replace the filter immediately



### 3. Tips

- 1** The filter element is a consumable item and needs to be replaced regularly.
- 2** The filter element replacement cycle is not the quality shelf life of the product.
- 3** Due to different use scenarios and frequency of use, the filter element replacement cycle varies. The specific use is based on the actual use.
- 4** Replace the filter element in a timely manner to ensure that the smoke filter reaches the best working state.

# Chapter 4

## Warranty and Declaration



### About this chapter

This chapter is about the warranty and declaration of the machine

Warranty and Declaration.....	4-1
Design Change .....	4-2
Warranty .....	4-3
Declaration of Conformity.....	4-4
Installation Risk Assessment.....	4-5
Machine Risk Assessment.....	4-6
Parts Diagram .....	4-7,8

## 1. Design Change

---

With the policy of constant improvement and/or modification to meet changing conditions, the right is reserved to change the design and/or specifications at any time without prior notification, and therefore specifications may vary and not be in accordance with this manual.

## 1. Guarantee (Limited Warranty)

---

Adkins warrants that the machine is free from defects in material and workmanship for a period of 12 months from the date of supply. The machine comes with a one-year warranty on parts.

This warranty covers all parts to repair the defects, except when damage results from misuse or abuse, accident, alteration or negligence or when a machine has been improperly installed.

If a machine is covered by warranty should need to be returned to the factory for examination and repair, if on-site component replacement is not possible Adkins will make every effort to repair the customers machine. The warranty will only be effective when Adkins authorises the original purchaser to return the machine to the factory and only when the product upon examination has proven to be defective.

Should in our opinion any part of this machine be defective in materials or workmanship, it will be replaced or repaired free of charge, provided that the press has been installed and operated in the correct manner and not subjected to misuse. In exceptional circumstances If Adkins authorise a replacement machine, the warranty of the replacement machine shall expire on the anniversary date of the original machines invoice to the customer.



In order for this warranty to be effective, no return of machine or parts may be made without prior factory authorisation. (This will exclude any travelling and/or carriage costs which will be charged at our discretion).

This is the sole warranty given by the company; there are no warranties, which extend beyond the description on the face hereof. The seller disclaims any implied warranty of merchantability and/or any implied warranty of fitness for a particular purpose; the buyer agrees that the goods are sold "as is". The sole purpose of the machine is to be used for DTF, outside of this use Adkins does not warrant the machine. The entire risk as to use, quality and performance of the machine lies with the customer. (No claim of any kind shall be greater than the sale price of the product or part to which the claim is made).

In no event will Adkins be liable for any injury, loss or damage, including loss of profits, destruction of goods or any special, incidental, consequential or indirect damages arising from the use of the machine or accompanying materials. This limitation will apply even if Adkins or its authorised agent had been advised of the possibility of such damage.

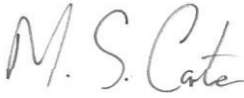

# A. ADKINS AND SONS LIMITED DECLARATION OF CONFORMITY

Application of Council Directives:	European Low Voltage Directive ( <b>LVD</b> ), European Machinery Directive ( <b>MD</b> ), Electro Magnetic Conformity ( <b>EMC</b> )
Standards to which Conformity is Declared:	( <b>LVD</b> ): EN 60204-1:2018 ( <b>MD</b> ): EN ISO 12100:2010 2006/42/EC Annex1 ( <b>EMC</b> ): EN 61000-6-2:2019
Manufacturer's Name:	<b>Charterhouse Holdings Plc</b>
Manufacturer's Address:	Oakridge Park, Trent Lane, Castle Donington, Derby DE74 2PY United Kingdom.
Type of Equipment:	DTF Inline Shaker Cure Unit
Standards Compliance:	 
Model Number:	..... DTF Inline Compact 600 Shaker Cure Unit
Serial Number:	.....
Year of Manufacture:	.....
I, the undersigned, hereby declare that the equipment specified above conforms to the above directives and standards.	
Place: Castle Donington, United Kingdom	Signature: 
Date: 15th June 2023	Full Name: Miles Carter Position: Chief Executive

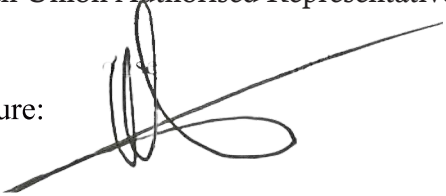
European Union Authorised Representative.	Address: LGI Netherlands B.V Kappstadweg 34A 1047 HG Amsterdam
Signature: 	
Full Name: Olej c'Loccobs	

## INSTALLATION RISK ASSESSMENT

Area / Task for assessment: Installation of Adkins Inline compact 600 DTF powder shaker with built in extraction

The guidance contained within this prepared assessment form will provide recommendations and indicate what action should be taken where hazards are identified.

Hazards Identified	Persons at risk and how	Manufacturer recommended control measures	Current risk			Recommended action necessary
			L	C	S	
<b>Trip and slip</b>	Persons installing machine – Could slip, trip, fall when moving/lifting goods	Engineer visually checks environment and has adequate PPE.	1	3	3	Persons receive sufficient training Keep environment around the machine tidy
<b>Manual handling</b>	Persons installing machine – Improper lifting techniques.	Training in manual handling techniques. Weights and dimensions listed within product manual. Recommended personnel required to lift details within user manual. Installation ramps included for ease of removing from pallet.	1	3	3	Persons be trained in manual handling techniques.
<b>Electric shock</b>	Persons installing machine – Shock from electrical circuit boards.	Isolate power supply if needed. Caution signage on display . Screw locked cover for electrics.	1	5	5	Persons be trained sufficiently in electrical safety and locations of highest risk of electric shock.
<b>Exposure to harmful isocyanates</b>	Persons installing machine – use of DTF powder risks exposure to isocyanates.	Training in the risk of exposure to isocyanates and sufficient product knowledge. PPE worn when necessary. Relevant H&S signage in place and/or explained in operator's manual.	2	4	8	Ensure that there is appropriate PPE at all times and that staff adhere to any applicable procedures.
<b>Burns</b>	Persons installing machine – burns from heat element and exposure.	Caution signage on display and explained in operator's manual. Protection from heat elements in place.	2	4	8	Ensure provision of a burns kit.
<b>Moving parts</b>	Persons installing machine – risk of injury or loss of limbs from moving parts.	Majority of moving parts are covered, meaning exposure is minimised.	1	4	4	Persons be trained sufficiently and adhere to any applicable procedures.

Risk Level	LCS Risk Score	Average Risk Score	5.17
LOW	< 8.00		
MEDIUM	8.00-14.99		
HIGH	> 14.99	Overall Risk Rating	LOW

**‘CURRENT RISK’ LCS SCORE SCHEME**

Overall Risk		Likelihood				
Consequence		1 (Improbable)	2 (Unlikely)	3 (Possible)	4 (Likely)	5 (Almost Certain)
1 (Negligible)	LOW	LOW	LOW	LOW	LOW	LOW
2 (Minor)	LOW	LOW	LOW	LOW	MEDIUM	MEDIUM
3 (Moderate)	LOW	LOW	LOW	MEDIUM	MEDIUM	HIGH
4 (Major)	LOW	LOW	MEDIUM	MEDIUM	HIGH	HIGH
5 (Catastrophic)	LOW	LOW	MEDIUM	HIGH	HIGH	HIGH

The overall score (Score (S)) is determined by multiplying the Likelihood (L) and the Consequence (C) for each Hazard Identified and taking the average score. A Score (S) below 8.00 is considered a low overall risk; a Score (S) between 8.00-14.99 is considered a medium overall risk; and a Score (S) above 14.99 is considered a high overall risk.

‘Current risk’ scores and the ‘Current risk’ LSC Score Scheme are only suggested by Adkins\* and encourage all users to perform their own risk assessment based on their specific environment and circumstances.

Adkins\* does not take responsibility for any action (or non-action) taken as a result of adhering or not adhering to recommendations listed in the ‘Recommended further action’ section.

Adkins\* does not take responsibility for any consequence arising from actions in the ‘Recommended further action’ section, including death or injury through negligence.

\*Adkins is a division of and trades as Charterhouse Holdings plc, Oakridge Park, Trent Lane, Castle Donington, DE74 2PY, United Kingdom.



## MACHINE USAGE RISK ASSESSMENT

Machine assessed: Adkins Inline Compact 600 DTF powder shaker with builtin extraction

The guidance contained within this prepared assessment form will provide recommendations and indicate what action should be taken where hazards are identified.

Hazards Identified	Persons at risk and how	Manufacturer-implemented control measures	Current risk			Recommended further action
			L	C	S	
<b>Electric shock</b>	Persons working with machine – Shock from electrical circuit boards.	Emergency Stop Button. Screw locked cover for electrics. Caution signage on display.	1	5	5	Users be trained su ciently in electrical safety and locations of highest risk of electric shock.
<b>Manual handling</b>	Persons working with machine – Improper lifting techniques.	Lockable wheels fitted to aid with movement of machine. Installation ramps included for ease of removing from pallet.	1	3	3	Users be trained in manual handling techniques.
<b>Exposure to harmful isocyanates</b>	Persons working with machine – use of DTF powder risks exposure to isocyanates.	Built-in extraction system for filtration of isocyanates. Cover placed over the powder trough. Outlined the risk of exposure to isocyanates. Relevant H&S signage in place and explained in operator's manual.	2	4	8	Ensure that there is appropriate PPE at all times. Users be trained su ciently and adhere to any applicable procedures.
<b>Burns</b>	Persons working with machine – burns from heat element and exposure.	Caution signage on display and explained in operator's manual. Protection from heat elements in place.	2	4	8	Ensure provision of a burns kit.
<b>Moving parts</b>	Persons working with machine – risk of injury or loss of limbs from moving parts.	Majority of moving parts are covered, meaning exposure is minimised. Caution signage on display and explained in operator's manual.	1	4	4	Users be trained su ciently and adhere to any applicable procedures.

Risk Level	LCS Risk Score	Average Risk Score	5.60
LOW	< 8.00		
MEDIUM	8.00-14.99		
HIGH	> 14.99	Overall Risk Rating	LOW

**‘CURRENT RISK’ LCS SCORE SCHEME**

		Likelihood (L)				
Overall Risk	Score (S)	1 (Improbable)	2 (Unlikely)	3 (Possible)	4 (Likely)	5 (Almost Certain)
Consequence (C)	1 (Negligible)	LOW	LOW	LOW	LOW	LOW
	2 (Minor)	LOW	LOW	LOW	MEDIUM	MEDIUM
	3 (Moderate)	LOW	LOW	MEDIUM	MEDIUM	HIGH
	4 (Major)	LOW	MEDIUM	MEDIUM	HIGH	HIGH
	5 (Catastrophic)	LOW	MEDIUM	HIGH	HIGH	HIGH

The overall score (Score (S)) is determined by multiplying the Likelihood (L) and the Consequence (C) for each Hazard Identified and taking the average score. An Score (S) below 8.00 is considered a low overall risk; a Score (S) between 8.00-14.99 is considered a medium overall risk; and a Score (S) above 14.99 is considered a high overall risk.

‘Current risk’ scores and the ‘Current risk’ LSC Score Scheme are only suggested by Adkins\* and encourage all users to perform their own risk assessment based on their specific environment and circumstances.

Adkins\* does not take responsibility for any action (or non-action) taken as a result of adhering or not adhering to recommendations listed in the ‘Recommended further action’ section.

Adkins\* does not take responsibility for any consequence arising from actions in the ‘Recommended further action’ section, including death or injury through negligence.

\*Adkins is a division of and trades as Charterhouse Holdings plc, Oakridge Park, Trent Lane, Castle Donington, DE74 2PY, United Kingdom.

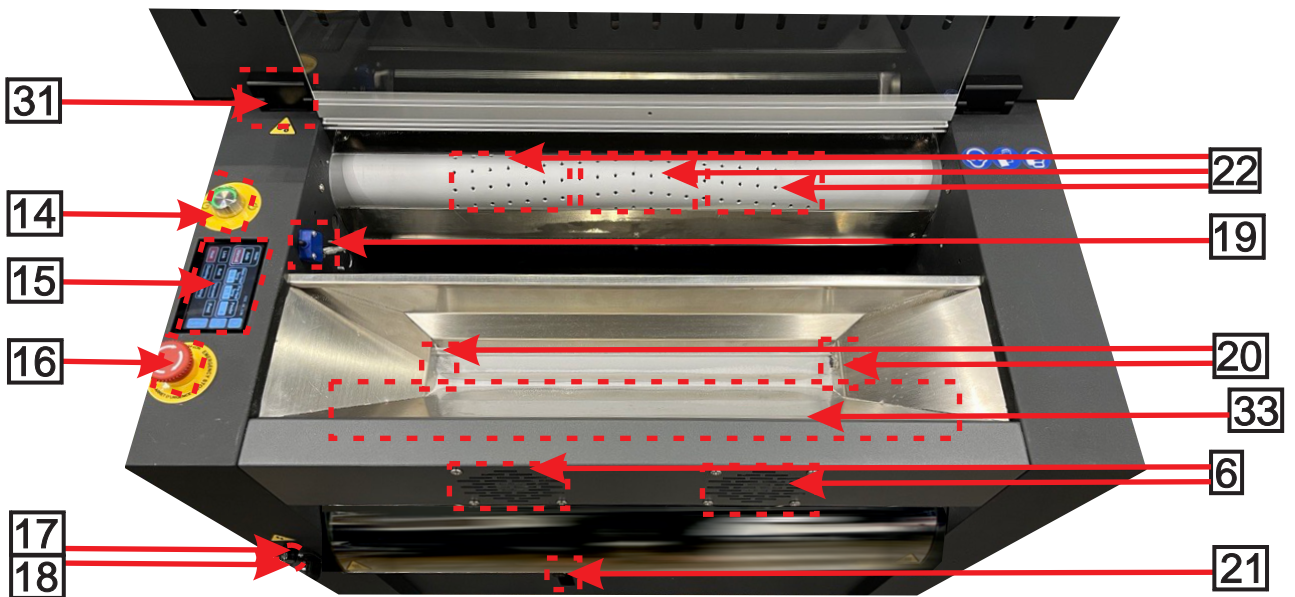
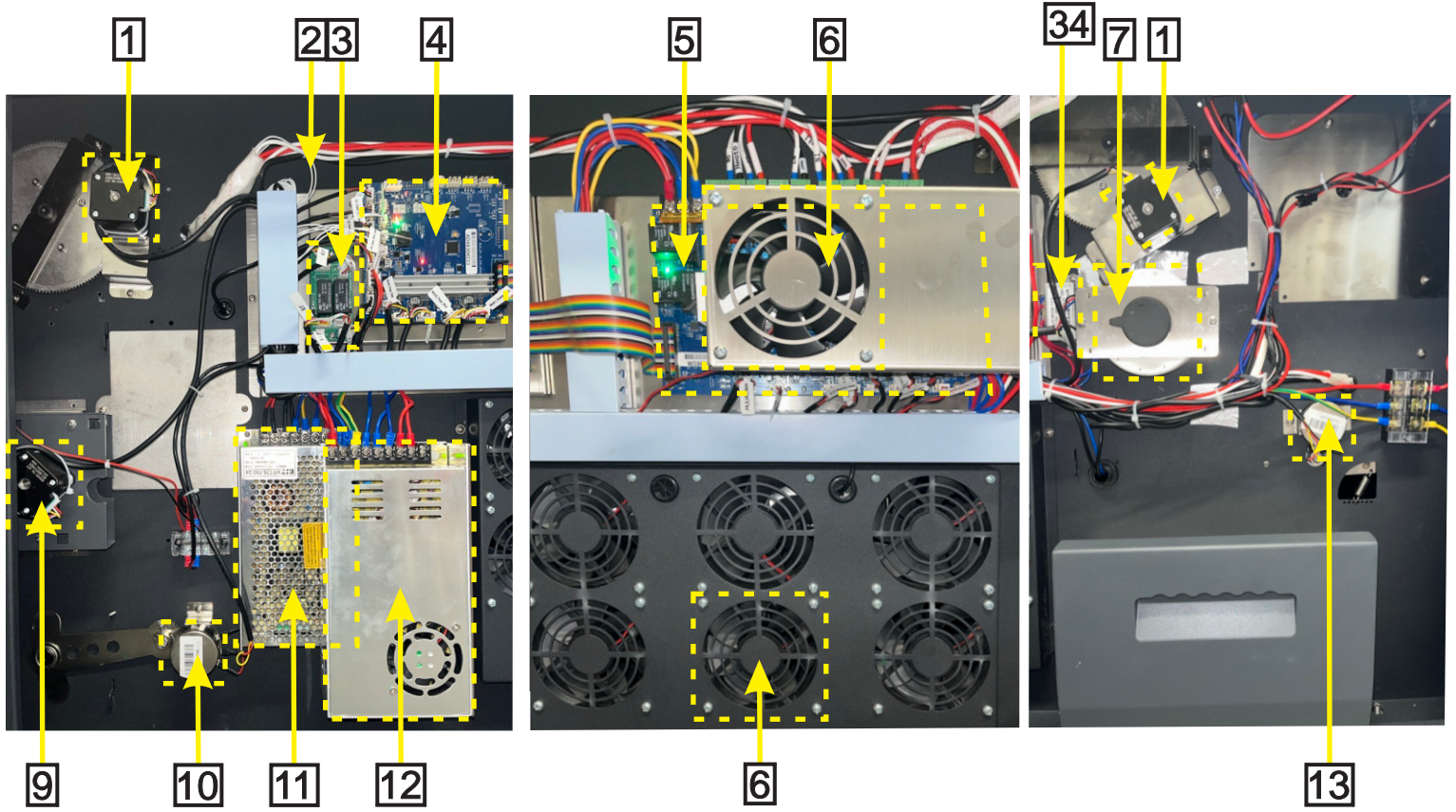

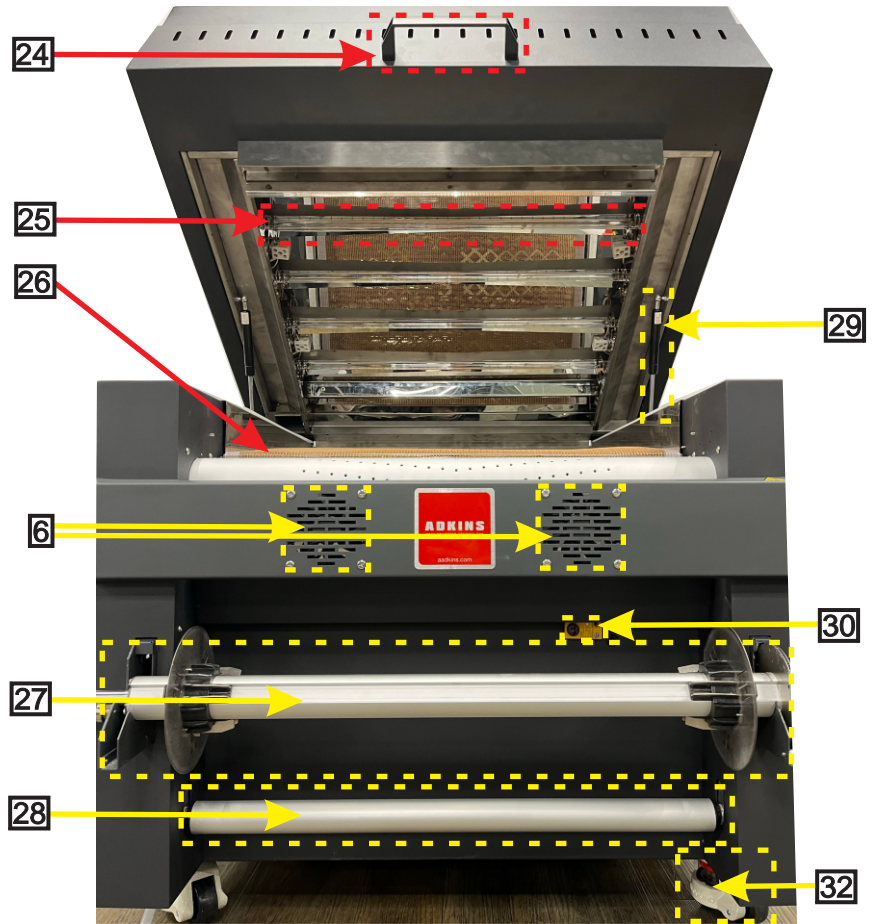
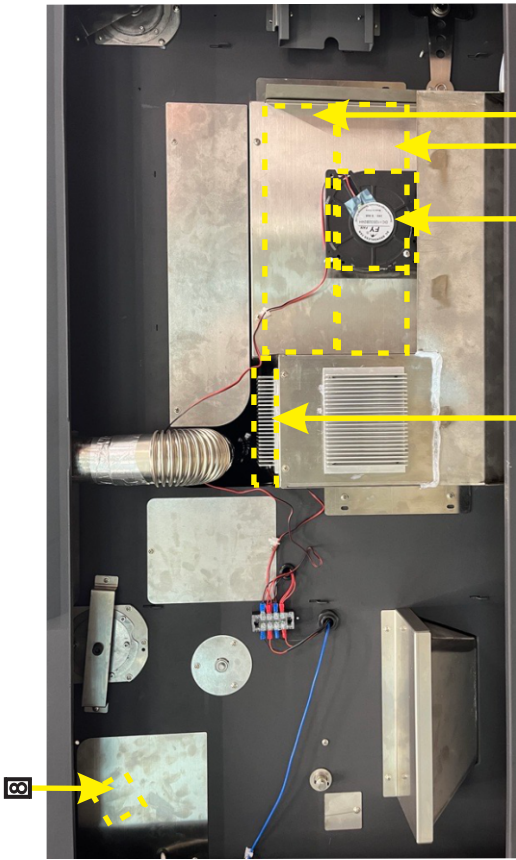

Diagram Number	Adkins Basic/Manual Description	Part code	Amount Per Machine
1	Vacuum Roller Motor	COM600-SUCT	1
2	Temperature Detection Line	1201-05-08-012	1
3	Stepper Switching Board	EE-15-056-A	1
4	Main Control Board	EE-15-047-C-N	1
5	Sixteen-way Thyristor Board	EE-15-049-C-N	1
6	Axial Fan (0.2a)	7101-11-09-003	11
7	Powder Shaking Motor	WZDK13-38G-3	1
8	Dusting Motor	800-600-DUST	1
9	Take Up Motor	800-600-TU	1
10	Tension and Gravity Sensor	AF-20-09-049A	1
11	24v Power Supply (6.5a)	EE-26-003-D	1
12	24v Power Supply (14.5a)	EE-26-003-B	1
13	Shaking Sensor	AF-20-09-049A	1
14	Main Power Switch	AF-22-09-23A	1
15	Touch Screen Display	AF-20-09-023A	1
16	Emergency Stop Button	AF-17-09-339A	1
17	Fuse Holder	EE-51-016-B	1

Diagram Number	Adkins Basic/Manual Description	Part Code	Amount Per Machine
18	Fuse (15amp)	EE-51-016-C	1
19	Shaking Safety Switch	EE-40-001-A	1
20	Powder Sensor and Receiver	EE-23-010-A	1
21	Front Film Sensor	7103-01-021B	1
22	Paper Suction Fan (1.2a)	EE-25-009-A	8
23	DTF Extraction Filters	AF-21-09-003A & AF-21-09-004A	1
24	Hood Handle	AF-16-09-761A	1
25	Top Heating Tube	V16E-17-13-020	4
26	Bottom Heating Tube	V16E-17-13-019	4
27	600mm Take Up Roller	V16A-01-02-84A	1
28	Tension Bar	V16A-04-01-001	1
29	Gas Strut	F2022-10-09-01	2
30	Rear Film Sensor	XR01-094	1
31	Hood / Door Hinge	AF-18-09-077	4
32	Wheel	AF-17-09-358A	4
33	Powder Trough Heat Element	SFJ/300-11-06-002	1
34	Isolation Transformer	AF21-09-009B	1