

ADKINS



Adkins DTF Pro Cure Oven

User Manual

Revision 1.0

Introduction	III
Caution	III
Requests	III
CE Statement	III
Product Appearance	III
Machines intended use	III
Airborne Sound Emission	III
Safety Precautions	IV
Symbols	V-VI
Unboxing and installation	VII
Working Environment	VII
Place of installation	VII
Temperature of working environment	VII
Chapter 1 - Before use	
Part Names and Functions	1-1
Fronts	1-2
Operating panel	1-3,4
Media tray	1-4
Purification	1-4
Chapter 2 - Basic Operations	
Workflow	2-2
Turning the Power On/OFF	2-3
Turning the power on	2-3
Turning the power o	2-3
Emergency Stop	2-3
Loading Media	2-4
Opening the Tray	2-4
Size of media	2-4
Operating Mode	2-5
Auto Mode	2-5,6
Manual Mode	2-7
Timer Hold	2-7

Chapter 3 - Maintenance Guidelines

Routine Maintenance	3-1
Before use.....	3-2
After use	3-2
Oven cleaning	3-2
filter box	3-2
Regularly replace the filter.....	3-3
How to replace filter box	3-3
Replacement cycle.....	3-3
Kind tips	3-3

Chapter 4 - Warranty and Declaration

Warranty and Declaration	4-1
Design Change	4-2
Warranty	4-3
Declaration of Conformity.....	4-4
Installation Risk Assessment	4-5
Machine Risk Assessment	4-7
Parts Diagram	4-9

Introduction

Thank you for purchasing Adkins DTF Pro Cure Oven.
DTF curing oven (Hereafter, "the machine").

Unauthorized reproduction of any portion of this document is strictly prohibited.

© Adkins All Rights Reserved. Copyright

Caution

Adkins is in no way liable for any damages whatsoever (including but not limited to lost profit, indirect damage, special damage, or other monetary damage) arising from using or inability to use the machine, except as provided in Adkins warranty provisions.

This applies even if Adkins has been informed of the possibility of such damages.

For example, we cannot be held liable for any loss of media or other materials from using the machine, nor are we liable for any indirect loss caused by printed materials.

Please note that we are not liable for any financial damage or lost profits resulting from the use of the machine, or for any claims from third parties.

Requests

- This manual describes the operations and maintenance of the machine.
- Illustrations in the manual may be different from the appearance of some models.
- Read this manual carefully and make sure you understand it before use.
- Although every effort has been made to ensure the accuracy of the information in this manual, if you find any issues, contact your dealer.
- This manual is subject to change without notice for improvement.

CE Statement

This equipment has been tested and found compliant with the requirements set forth in the declaration of conformity.

Product Appearance

Please note that the descriptions of the product appearance in the operating manual are primarily based on the product you actually receive. While ensuring the main functionality of the product remains unaffected, we continuously make subtle adjustments to the product appearance to achieve optimal design. These adjustments aim to enhance the overall look and feel of the product, providing you with an improved user experience.

In the case of significant changes, we will promptly notify you through the appropriate channels, ensuring that you stay informed about the latest product information.

Machines Intended Use

Automatic curing and fixation machine for direct-to-film transfer media s. Curing and melting the fixing powder to the ink on the transfer film to produce a garment decoration transfer.

The machine has built-in filtration and extraction for the removal of any by-products produced through the heating process. All components of the direct-to-film process is suitable for commercial use.

The machine is only for the intended use stated above. Any misuse of the machine outside of being used for the powdering and fixation of direct to film powder or to direct to film media s is strictly ill-advised and not covered within the manufacturers warranty.

Inserting anything other than direct to film powder or direct to film media into the machine could lead to damage to the machine and injury to users of the machine.

Airbourne Sound Emission

During use the A-Weighted Sound Emission is 70db(A) or lower

Do not leave this machine unattended whilst in operation









Do not let unauthorised, unqualified or untrained people use machinery never allow children to operate or help at the machine.

Safety Precautions

Symbols

In this manual, symbols indicate and explain precautions. The indicated symbol varies depending on the nature of the precaution. Make sure you understand the meaning of each symbol and use the machine safely and correctly.

Example of symbols

Meaning	
	Failure to observe the instructions given with this symbol may result in death or serious injuries to personnel. Be sure to read the precaution carefully and use the machine
	Failure to observe the instructions given with this symbol may result in injury to personnel or damage to property.
	Important notes regarding use of the machine are given with this symbol. Use as reference information.
	Useful information is given with this symbol. Use as reference information.
	Indicates the corresponding page for related information.
	Indicates a precaution requiring attention (including cases of danger or warnings). Specific precautions are shown in the figure.
	Indicates a prohibited action. Specifically prohibited actions are shown in the figure.
	Indicates an action that must be taken or instructions that must be followed. Specific instructions are shown in the figure.

Warnings and precautions in use

WARNING



The set of power cables provided with the machine is for use only with the machine and cannot be used with other electrical devices. Do not use any power cables other than the ones provided with the machine. Failure to observe these instructions may result in fire or electric shock.

- Do not attempt to modify the cable, and avoid damaging or breaking it. Placing heavy objects on, heating, or pulling the cable may damage it, which may result in fire or electric shock.
- Avoid use in humid places. Additionally, do not pour water on the machine. Failure to observe these instructions may result in fire, electric shock, or failure.
- Use of the machine under an abnormal condition, as when it is emitting smoke or fumes, may result in fire or electric shock. Turn off the power switch immediately, and then be sure to unplug the machine from the outlet. Once you have confirmed that smoke is no longer being emitted, request repair from your dealer. Never attempt to repair the machine yourself. Doing so is hazardous.

- Never disassemble or modify the machine. Failure to observe these instructions may result in electric shock or failure.
- Do not use extension cords. Failure to observe these instructions may result in fire or electric shock.
- Keep foreign objects such as pieces of metal away from the power plug prongs. Failure to observe these instructions may result in fire or electric shock.
- Do not overload electrical outlets by using too many pieces of equipment. Failure to observe these instructions may result in fire or electric shock.
- If the power cable is damaged or the core wire is exposed or broken, ask your service representative to replace it. Using it as is may result in fire or electric shock.
- Do not handle the power plug with wet hands. Failure to observe these instructions may result in electric shock.
- Always hold the power cable by the plug when unplugging the machine. Do not unplug by holding the power cable. Failure to observe these instructions may damage the cable or result in fire or electric shock.
- Do not use a voltage other than the indicated voltage. Failure to observe these instructions may result in fire or electric shock.
- Do not use a power frequency other than the indicated frequency. Failure to observe these instructions may result in fire or electric shock.
- If metal, water, liquid, or other foreign objects enter the machine, turn it off immediately. After that, be sure to unplug the machine and contact your service representative. Using it as is may result in fire or electric shock.
- If ink leaks, turn off the main power switch, unplug the machine, and contact your dealer, service office, or call center.
- Keep the heater on the media transport surface free of dust and debris. Failure to observe these instructions may result in sparks or fires.
- Keep children away from this machine.



- Do not use a flammable spray or solvent inside or around the machine. Failure to observe these instructions may result in fire or electric shock from ignition.
- Do not place vases, pot plants, cups, cosmetics, containers of chemicals or water, or small metal objects on top of the machine. Liquid or foreign objects may get inside the machine, leading to fire or electric shock.

Precautions in use

CAUTION

Handling of the power cable



- Plug into a polarized electrical outlet.
- Always plug the power cable into an outlet near the machine, and make sure the power cable can be easily unplugged.
- Regularly (at least once a year) unplug the cable and remove any dust on or near the power plug. Failure to remove dust may result in fire.
- Do not use a voltage other than the indicated voltage.
- Before plugging in the machine, check the outlet supply voltage and circuit breaker capacity. Plug each cable into a power source with an independent breaker. If you plug more than one power cable into outlets that share the same circuit breaker, it may trip the



Notes on maintenance



- Pay close attention to ventilation and be sure to wear safety glasses, gloves, and a mask when dealing with unused hot melt powder, airborne particles may enter the eyes or mouth. Please take precautions.

Moving part precaution



- Keep fingers and other body parts away from hazardous moving parts.
- Do not touch the dusting roller when it is rolling. Failure to observe these instructions may result in finger injury such as torn skin or fingernails.
- Keep your head and hands away from moving parts during operation. Failure to observe these instructions may result in injury such as your hair becoming caught in the machine.
- Wear suitable clothes. (Do not wear loose-fitting clothes or accessories.) Keep long hair bound.



CAUTION

Heater



- Do not pour liquid on the media transport surface. Failure to observe these instructions may result in heater failure or sparks.
- Do not touch the media transport surface with bare hands while the heater is hot. Failure to observe these instructions may result in burns.

Precautions and notes

WARNING

Consumable items



- Machine consumables, including hot melt powder and transfer film.
- The machine's safety level is based on the use of Adkins recommended transfer film. To ensure operational safety, please use the transfer film recommended by Adkins.
- If hot melt powder is brought from a cold place to a warm place, please let it sit at room temperature for at least three hours before use (refer to product info for full details).
- Do not leave consumables exposed to the air for an extended period; if left open for a long time, they may not transfer properly. If not in use, seal and store them.
- Store consumables in a cool, dark place.
- Keep consumables out of reach of children.
- Once consumable packaging is opened, please use it within half a month. After a certain period of time, the transfer quality may decline. Refer to specific product details.
- Please hand over unused consumables to your dealer or service representative. If handling them yourself, comply with the requirements of industrial waste disposal facilities and local regulations.

Components requiring periodic replacement



- Some parts of the machine require regular replacement.

Machine disposal



- Contact your dealer or service representative for assistance when disposing of the machine. If you will dispose it by yourself, request assistance from an industrial waste disposer.

WARNING

Notes on maintenance

- Use in a room with as little dust as possible.
- Use in a room with as much ventilation as possible.
- **Important:** Regularly wipe the oil tank to keep it clean and prevent oil accumulation.
- Store transfer film in a bag. Wiping off dust accumulated on the media will adversely affect the media due to static electricity.
- When leaving the workshop after working hours, do not leave any media on the roll hanger. Dust will adhere to the media.

WARNING

Handling of Media

- Use recommended media. Please use the media recommended by Adkins to ensure reliable, high-quality transfers.
- Be aware of media expansion and contraction. Do not use media that has just been opened. The media may expand or contract depending on the room temperature and humidity. Open the package and allow it to adjust to the place of use for at least 30 minutes before loading it in the machine.
- Do not use curled media. Not only does this cause media jamming, but it also affects transfer quality. Straighten any media that is significantly curled before use. When rolling up regular-sized coated media for storage, make sure the coated side is facing outward.
- Set the heater temperature to suit media characteristics.
- Do not leave media loaded over extended periods with the heater on.
- With some types of media, under high temperature and humidity, it may affect the transfer. Be careful about where media is stored.
- With some types of media, if the media is left exposed to air, the ink-receiving layer may change, causing image defects such as blurred colors and bleeding.

Warning signs and Mandatory signs

Warning Signs



“Warning; electricity” and it is used to warn people about the risk of coming into contact with electricity (e.g. electric shock, electrocution hazard, hazardous voltage).



“Hot Surface” and it is used to warn people to take care to avoid coming into contact with a hot surface.



“Crushing Hazard” and it is used to warn people to take care to avoid coming into contact with moving parts during operation.

Installation precautions

places exposed to direct sunlight



places with uneven surfaces



places where vibration is generated



Places directly exposed to air conditioning

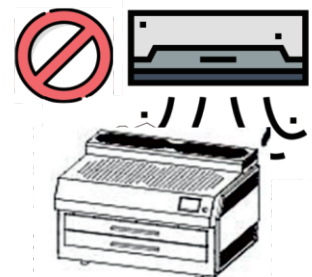

Places subject to significant changes in temperature or humidity

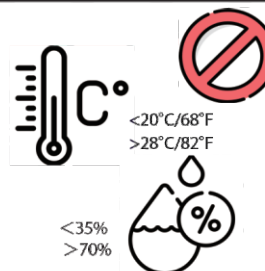

Places where open flames are present

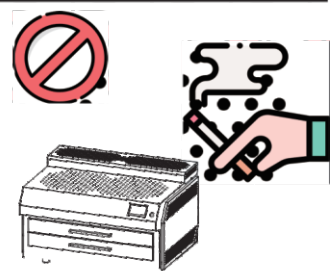

Unboxing and installation

Unboxing

Before installing the machine, ensure that the required amount of space is available in the place under consideration. The place of installation must have enough space for the machine as well as transferring tasks. See overleaf.



Place the box in a position that is flat and level, and that you have sufficient space to unbox and remove the machine from the pallet.

Remove the securing banding. It is recommended that 2 people lift the lid upwards and over the machine, taking care not to damaged/scratch the outer surfaces.



The protective wrapper and packaging can be removed from the machine.

Installation

- 1 Position the machine close to the printer that s to be used.
- 2 Connect the plug to a suitable plug socket (do not use an extension lead) and switch on via the red on/off button. (Right side of machine) If the system does not turn on, make sure that the emergency stop is not engaged.
- 3 Ensure the power lead is not going to come in to contact with any moving parts or any heat source and does not constitute a trip hazard.

Working Environment

Places of installation

Before installing the machine, ensure that the required amount of space is available in the place under consideration. The place of installation must have enough space for the machine as well as transferring tasks.

Width	Depth	Height	Total Weight
850mm	675mm	540mm	85kg

Top View

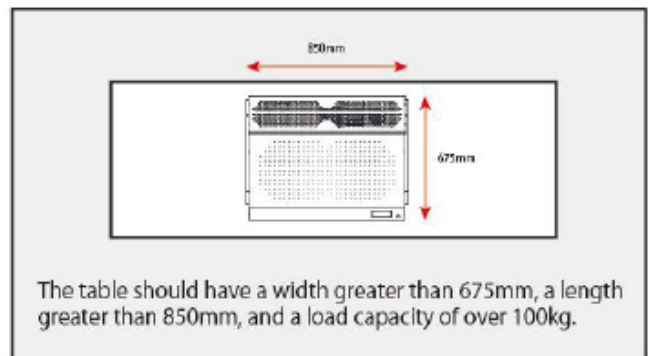

Side View

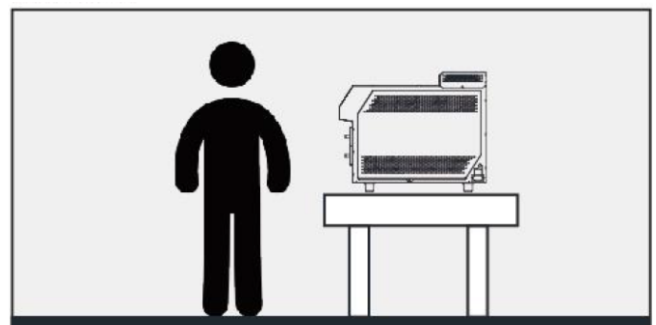

Temperature of working environment

To ensure reliable transferring, use the machine in an environment of 20 - 28°C.

Chapter 1

Before Use



About this chapter

This chapter describes information to know before use, such as part names and installation instructions.

Part Names and Functions	1-1
Fronts	1-2
Operating panel	1-3,4
Media tray	1-4
Purification	1-4

Part Names and Functions

Front

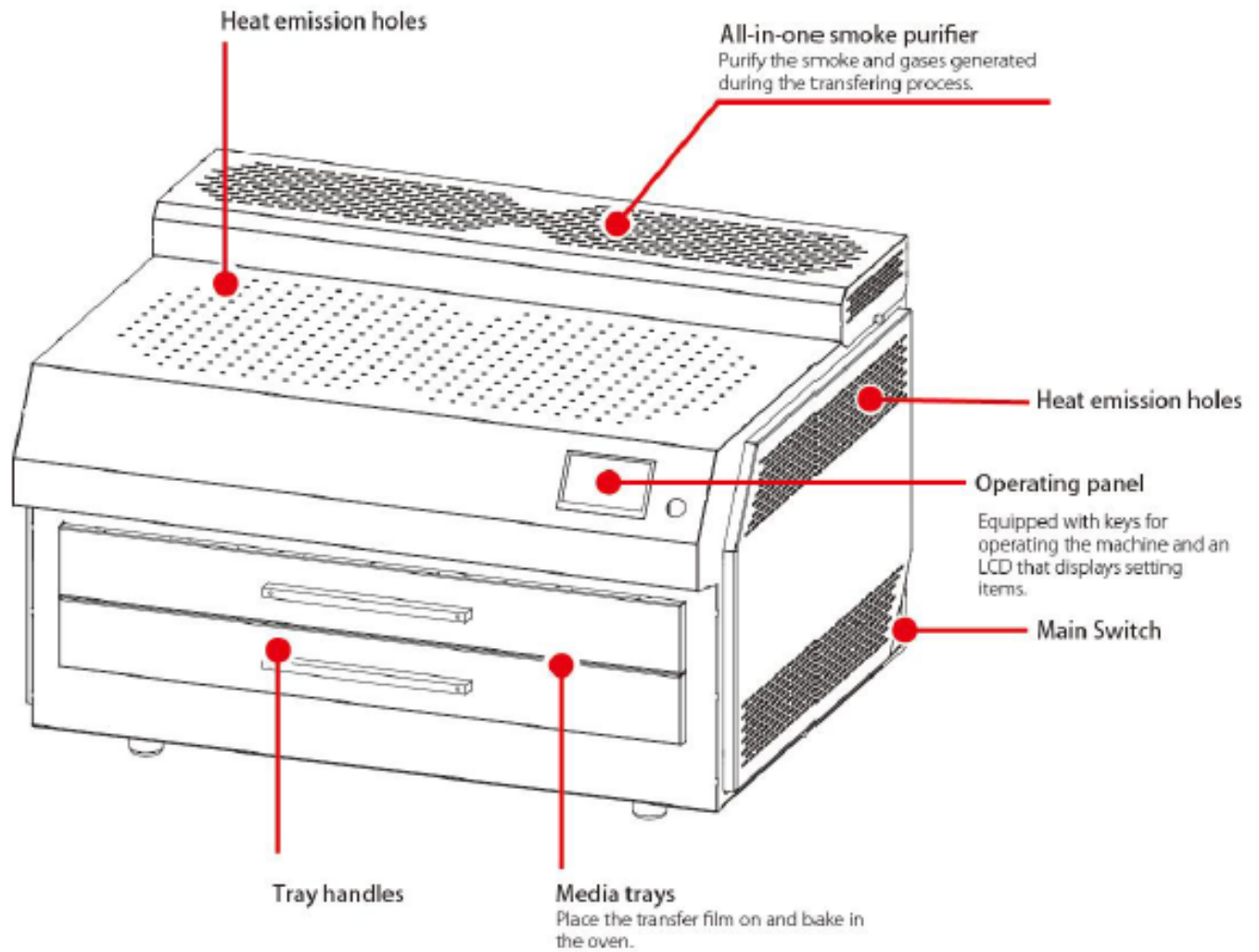

Left surface

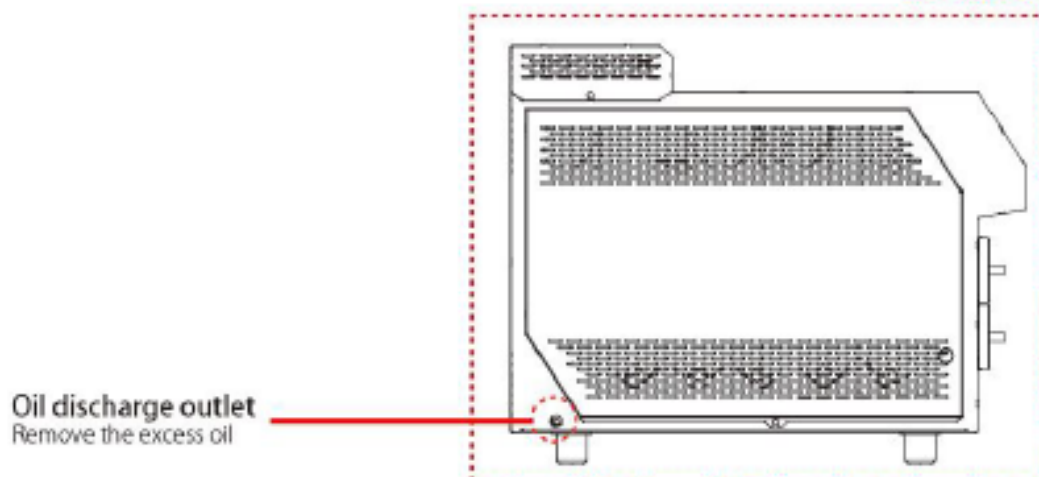

Operating Panel

Use the operating panel to specify print settings or operate the machine.

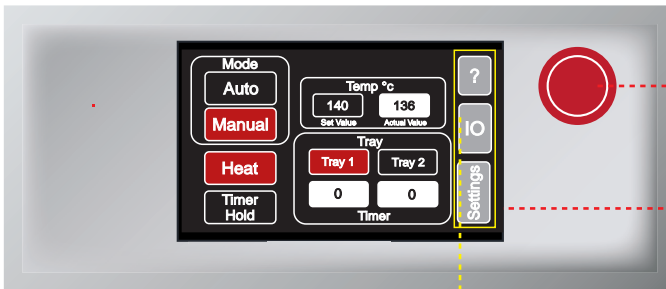

Main Menu Bar
Help / IO / Settings

Emergency Stop

Press to quickly and immediately halt the operation of the machine in case of an emergency or potential hazard

Intelligent touch display

Shows the following items:

- Auto/manual mode
- Oven Temp (Setting Value / Current Value)
- Two Setting Functions (Heat / Timer Hold)
- Tray Timer (Tray 1 / Tray 2)
- (IO) Input/Output setting
- Settings
- Main menu

1. Function introduction

Icon	Details
Heat	To activate the machine's heating function.
Timer Hold	When the trays enter the oven, Press to stop the timer and it will not continue to countdown and keeps the trays inside.
Tray 1	Toggle to control the top tray to open/close (Only in manual mode)
Tray 2	Toggle to control the bottom tray to open/close (Only in manual mode)

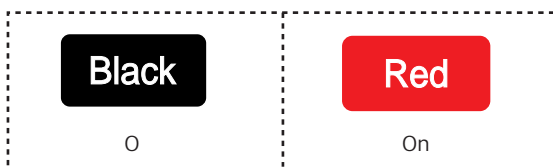

2. Temperature

Icon	Details
Set Value	Show the setting temperature of oven.
Actual Value	Show the current temperature of oven.

3. Auto/Manual mode

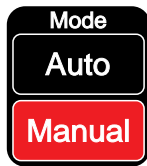

Auto mode:
When set to auto mode the machine

Manual mode:
In manual mode, the machine allows adjustment of various parameters, enabling real-time monitoring and adjustment of machine operations giving full manual control.

4. Settings

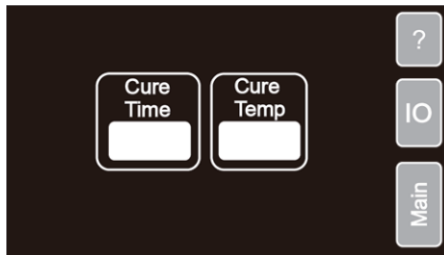

1) Curing Time
Setting the curing time after the tray enters the oven

1) Curing Temperature
Operating temperature of the oven

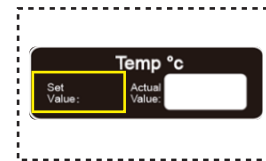
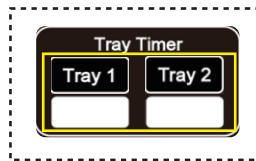

5. Input/output settings

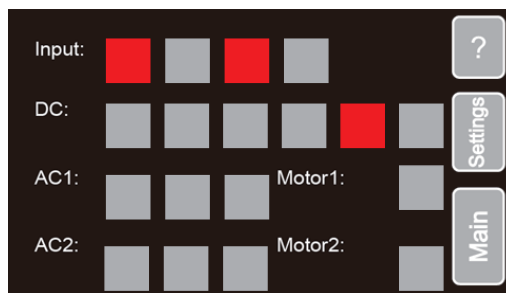

- The displayed parameters here correspond to the working status of their respective names and do not support manual adjustment.
- Icon color varies depending on the function working status.
Red: Working status can not meet the standards
Gray: Working status meets the standards



To determine the specific working status, please contact your dealer or press the "?" button to know more.

Media Tray

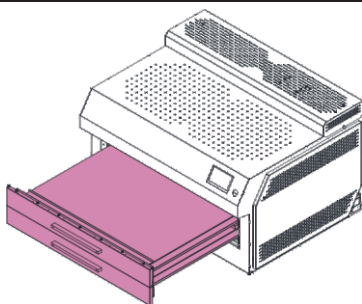

The curing oven is equipped with two trays that can be used alternately, but not simultaneously. The trays can be manually opened and closed or operated by pressing Tray 1, Tray 2 buttons on the control panel.



If you need to open the tray manually, simply pull the tray handle gently, and the tray will open automatically. Similarly to close the tray manually just push the handle lightly. * This only works in manual mode and not in auto.

Purification

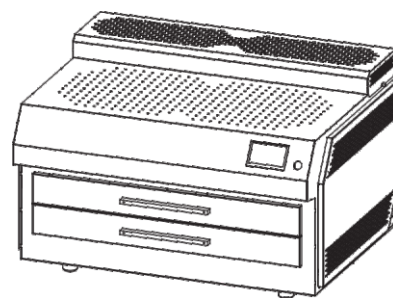

Each curing oven is equipped with a filtration box that purifies the smoke inside the oven during operation. This helps protect the environment and prevents the production of fumes and oil vapours.

Chapter 2

Basic operation



About this chapter

This chapter describes information about basic operation, such as how to load printing media, how to use auto mode and link mode correctly.

Workflow	2-2
Turning the Power On/OFF	2-3
Turning the power on	2-3
Turning the power o	2-3
Emergency Stop	2-3
Loading Media	2-4
Opening the Tray	2-4
Size of media	2-4
Operating Mode	2-5
Auto Mode	2-5,6
Manual Mode	2-7
Timer Hold	2-7

Workflow

1

Turning the power on/o

See [turning the power on/o]
Page 2-3.

2

Loading media

See [Loading Media] Page 2-4.

3

Settings Menu

See [Settings Menu] Page 2-5.

4

Operating Modes

See [Auto mode] Page 2-5,2-6.
See [Manual mode] Page 2-7.
See [Timerhold] Page 2-7.

Turning the power on/o

Turning the power on

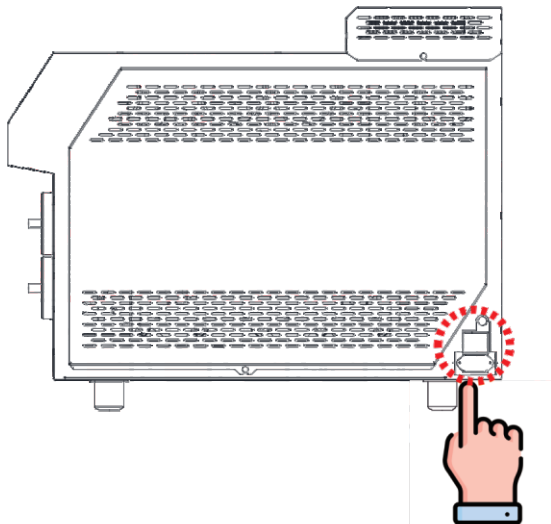

Press to turn on the machine

Turning the power o

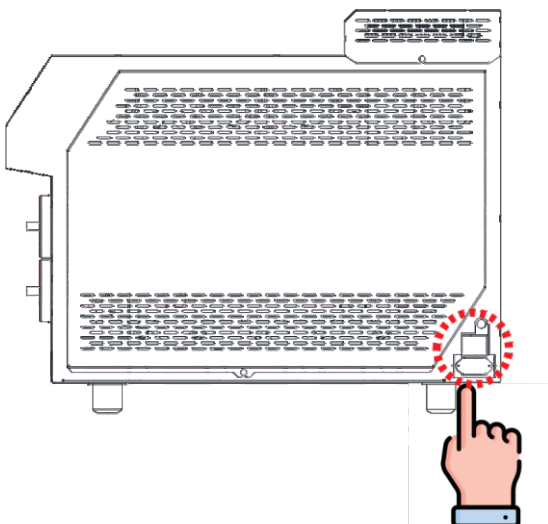

Press to turn off the machine



Please ensure that the machine completes the transfer operation before turning o the power

Emergency stop

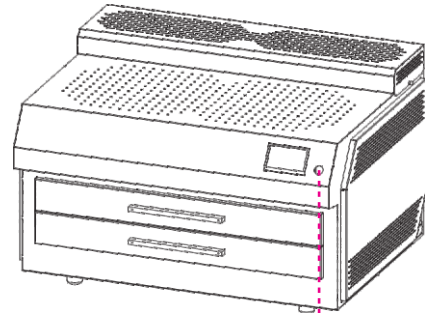

- 1) Press to activate
- 2) Rotate the button to the right to exit the emergency stop state

WARNING

Emergency Stop



Emergency stop can be activated only in the following situations:

- Emergency Scenarios: In case of emergencies or potential hazards, the emergency stop button or switch is used to quickly initiate the emergency stop. This rapidly halts all movements of the machine to prevent injuries or equipment damage.
- Loss of Control: If the operator loses control of the machine and is unable to handle unforeseen circumstances, the emergency stop is employed to swiftly halt the machine operations.
- Equipment Malfunction: When there is a malfunction or abnormal operation of the equipment, the emergency stop helps prevent further damage and protects both operators and the equipment.
- Safety Checks: During maintenance or safety checks, it may be necessary to activate the emergency stop to ensure the safety of personnel.



It's important to note that the emergency stop is intended for responding to urgent situations or ensuring safety, so it should be used sparingly under normal circumstances. After activating the emergency stop, a proper inspection and maintenance of the machine are usually required to ensure its safety and normal operation.

Loading Media

Open the Tray

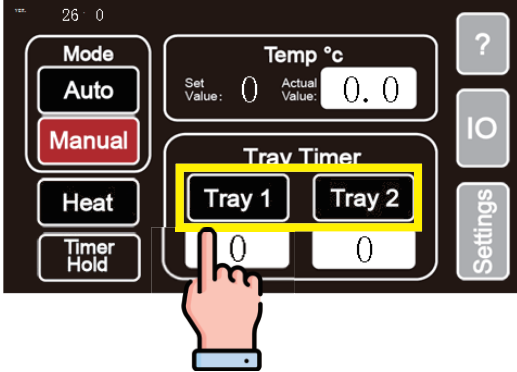

Press "Tray 1" and "Tray 2" to control

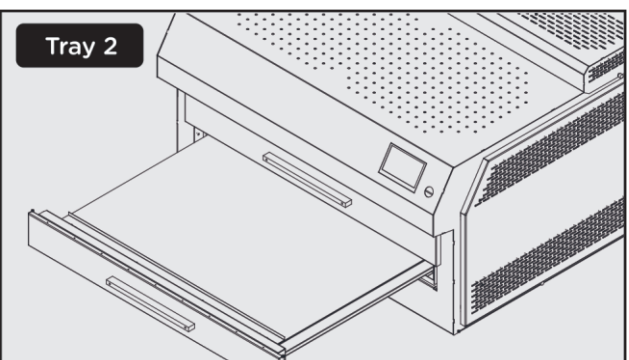
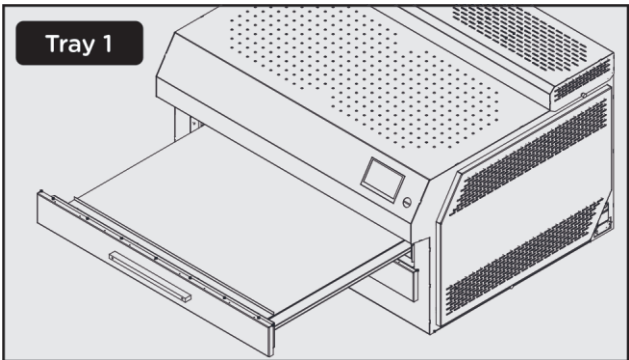

Size of Media

Maximum sheet size 400 x 600mm

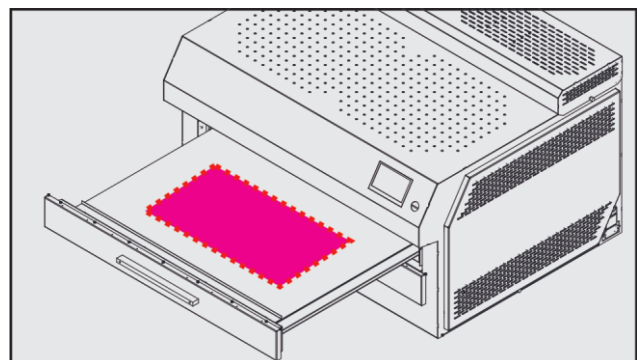

Multiple sheets can be placed on to any of the trays.
i.e two A3 sheets

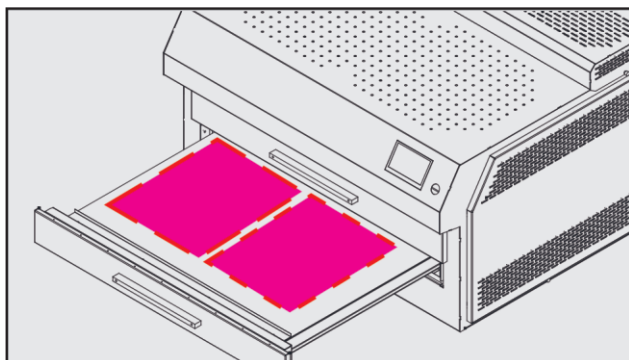

Settings Menu

Curing Time

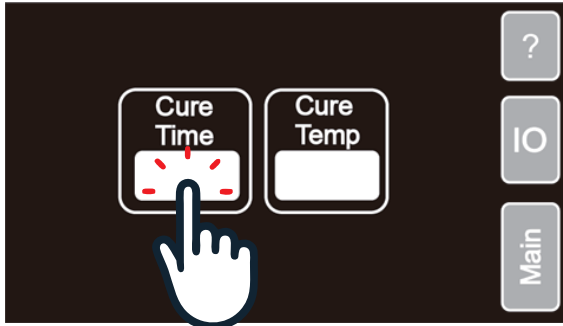

Click the white box under "cure Time" to input the desired curing time.

The unit for the input value is seconds.

Value range 30-900seconds.

Curing Temperature

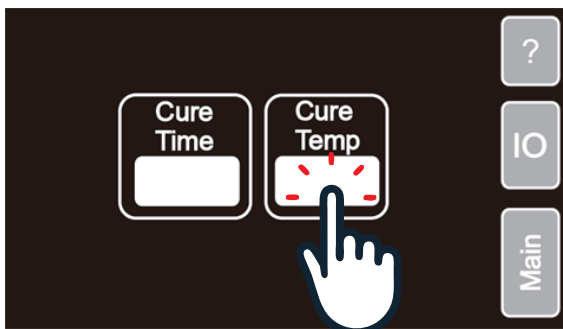

Click the white box under "cure Temp" to input the desired curing temperature.

The unit for the input value is seconds.

Value range 50-140°C.

Operating Mode

Auto Mode

In automatic mode, the machine supports alternating curing of multiple sheets, but not simultaneous curing in both trays. If you need to cure multiple sheets alternately, please follow the steps below.

1 Set time and temp settings.

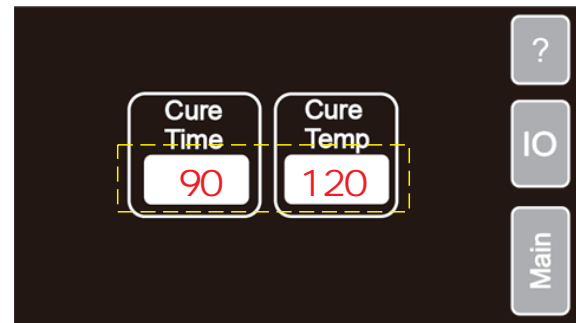

2 Switch to Auto mode.
Turn on "Heat" function

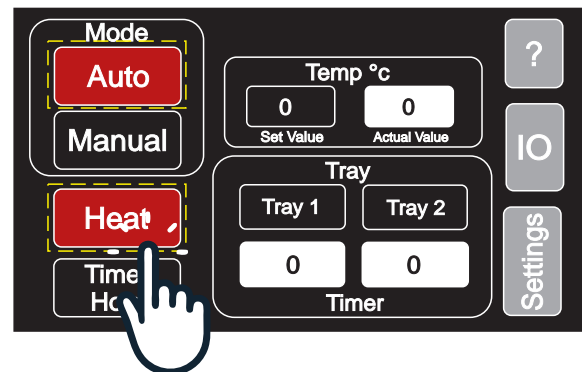

 The values shown in the image are for reference only. Please adjust the values according to your actual needs.

Both trays will now open ready to accept the media.

Now after completing the above two machine setup steps, you need to wait for the machine to meet the following conditions before starting automatic mode.

- 3** Wait until the actual temperature reaches set value.

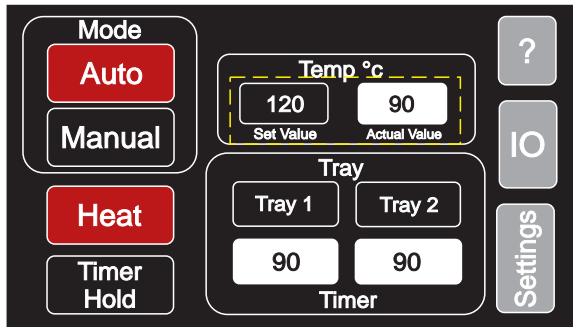

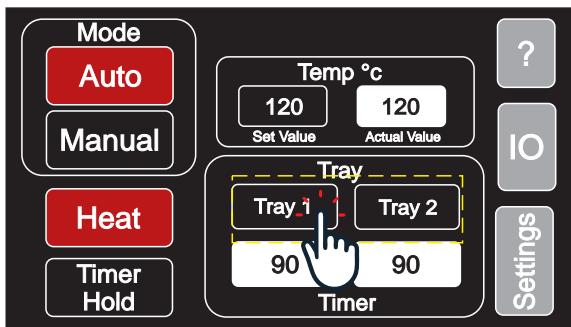

The actual temperature of the oven must reach the set temperature. For example, if the set temp is 120°C, you need to wait until the actual value reaches 120°C.

- 4** Place the media sheet in tray.

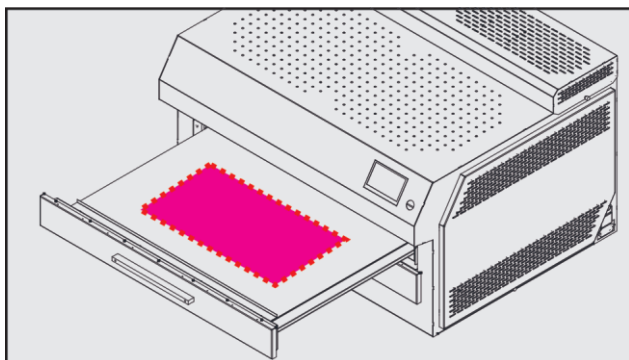

Once the actual temperature is reached, Tray 1 will close and the timer will begin to countdown.



 The trays cannot be opened until the actual temperature of the oven reaches the set temperature.

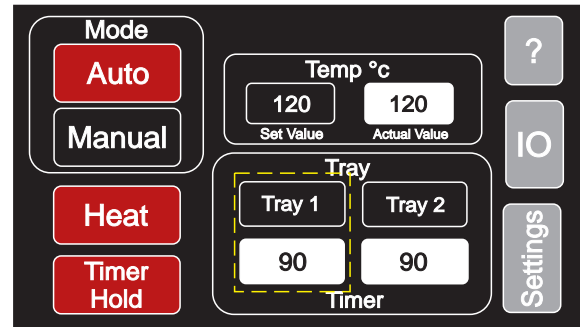

After closing Tray 1, the white box under "Tray 1" on the control panel will start the countdown timer.

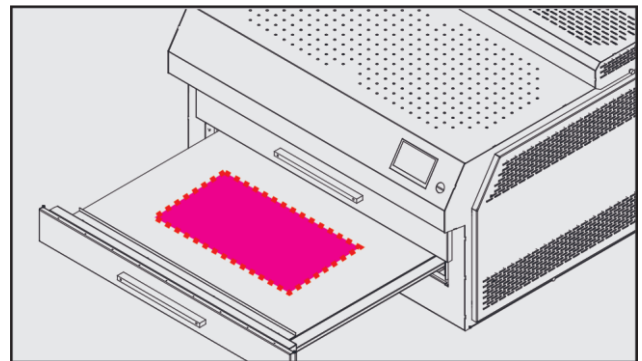

At the same time, Tray 2 will open automatically. You can then place the media on the second tray.



You have 90 seconds to remove the cured media sheet and replace it with a new one. This time is determined by the Curing time you have set. If you set a longer curing time, you will have more time to perform the operation.

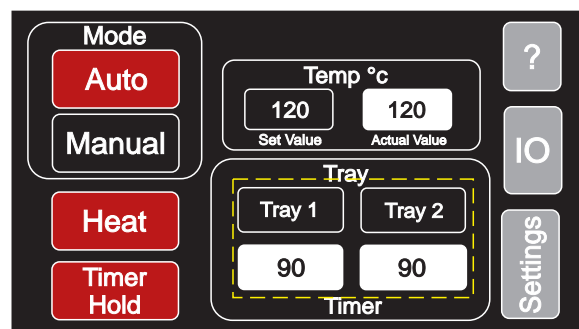

When the countdown for Tray 1 ends, Tray 2 will automatically move into the oven and start curing, with its own timer beginning. At this point the media sheet on Tray 1 will have been cured, replace it with a new media sheet on tray 1, once tray 2 finishes curing and ejects automatically, Tray 1 will move into the oven and start curing.

This process will continue alternately.

Manual Mode

In manual mode, the machine supports alternating curing manually and trays can be opened at any point during curing.

- 1 Switch to Manual mode. Turn on "Heat" function

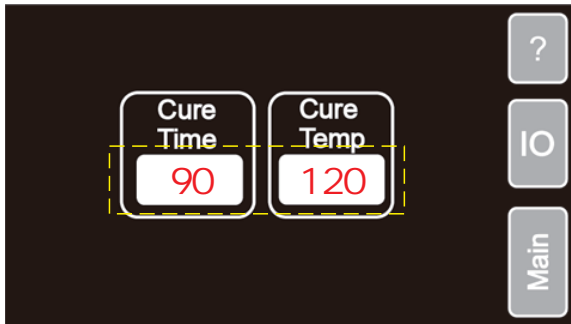

- 2 Set time and temp settings.

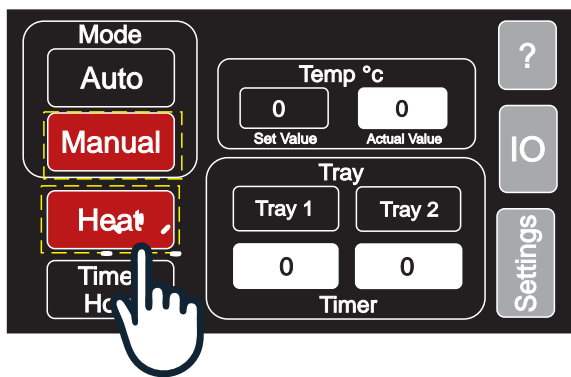

 The values shown in the image are for reference only. Please adjust the values according to your actual needs.

Now after completing the above two machine setup steps, you need to wait for the machine to meet the following conditions before starting.

- 3 Wait until the actual temperature reaches set value.

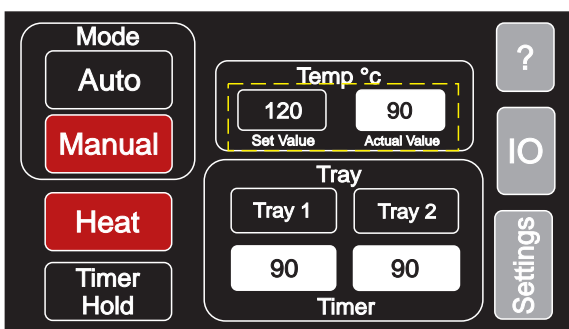

The actual temperature of the oven must reach the set temperature. For example, if the set temp is 120°C, you need to wait until the actual value reaches 120°C.

- 4 Place the media sheet in tray.

Once the actual temperature is reached, you can open either tray. Here we take Tray 1.

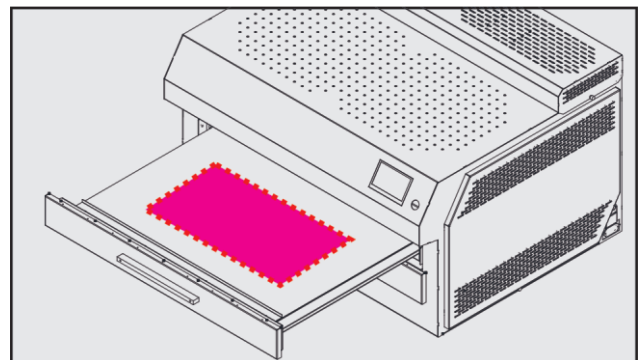
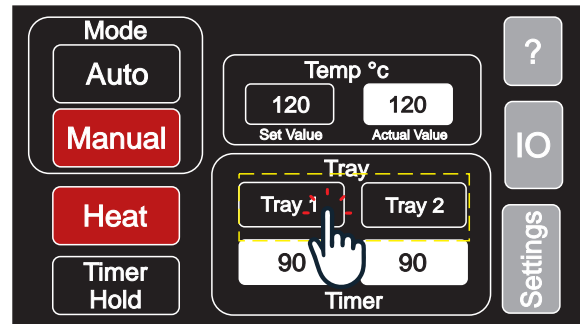

After placing the media, Press "Tray 1" to close it again.

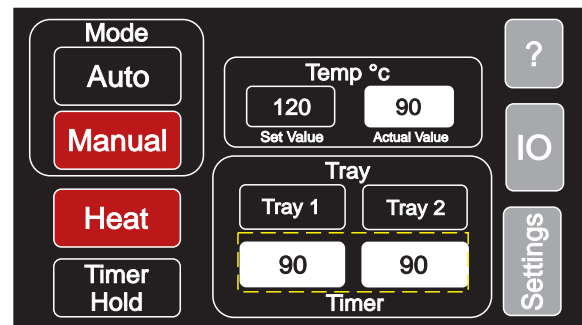

In manual mode after the tray countdown ends it will automatically eject, completing the curing process.

Timer Hold

Timer Hold

The "Timer hold" function key can only be used in manual mode. Its purpose is to accelerate the oven's temperature to reach the set temperature more quickly.

In manual mode after setting the time and temperature in the "settings" menu the tray will still automatically ejects out after the countdown ends. At this point the Timer hold function stops the countdown, preventing the trays from opening. This helps to ensure the oven's temperature does not dissipate allowing the machine to reach the working state more quickly

Chapter 3

Maintenance Guidelines



About this chapter

This chapter is about some daily maintenance guidelines of the machine, properly maintaining the machine can extend

Routine Maintenance	3-1
Before use.....	3-2
After use	3-2
Oven cleaning	3-2
Filter box.....	3-2
Regularly replace the filter.....	3-3
How to replace filter box	3-3
Replacement cycle.....	3-3
Tips	3-3



Due to the large amount of glycerin in the composition of DTF white ink, it is normal for oil and water condensation to appear. In order to prevent condensation from accumulating on the machine during long-term use, please follow the maintenance instructions below.

Before use



It is recommended to turn on the Heat function for 10 mins before starting each work session to enhance the curing effectiveness.

1 Pre-Work Heating

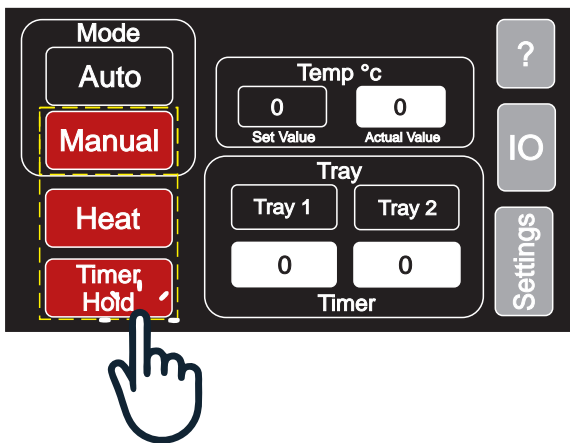

After use



After each day's work, be sure to activate the Heat function for 15 minutes to reduce water and oil condensation.

1 Post-Work Heating

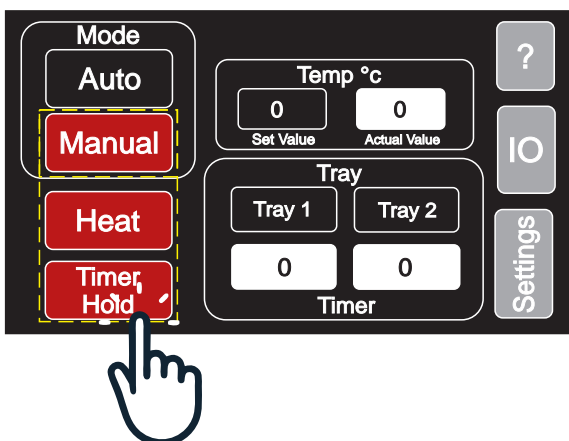

If the weather is humid, an extra 10-15 minutes may be necessary

Oven cleaning

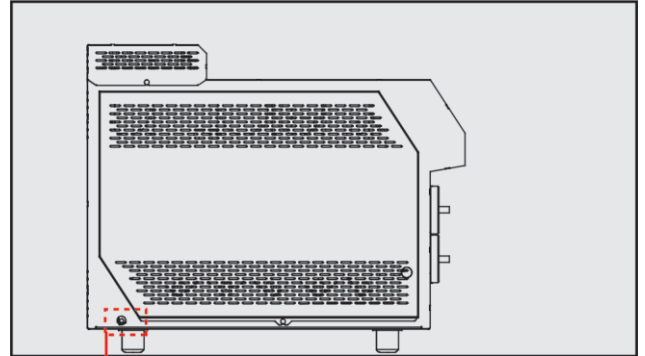

Every two to three weeks, open the bottom valve of the filter to drain the collected oil.



Due to the build up of glycerin/oil which comes from DTF ink it is extremely important that time is taken at each day to thoroughly clean excess oil from all surfaces

The oil residue cannot be fully eradicated due to the oil particles becoming airborne, which forms condensation on various parts of the machine.

Failure to clean the surfaces daily can result in oil build up and leakages from various parts of the system and can contribute possibly faults.

Replace the filter regularly

Replace the filter cartridge regularly according to the working condition, refer to the filter cartridge replacement guideline (as below):

1. How to replace the filter box



1

Open the Smoke purifier.

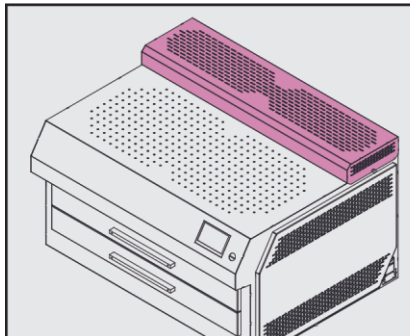

2

Loosen the screws securing the filter, box panel then to reveal the filters

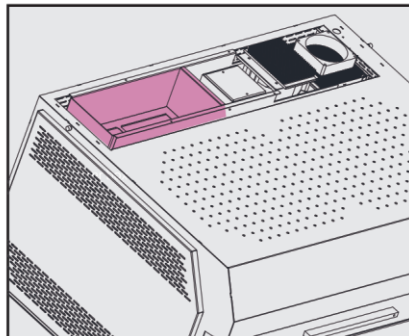

3

Pull the old filters out and install the new filters (Carbon at the bottom).



2. Replacement cycle

Use status	Suggested replacement cycle
High frequency use	1.5 months
Low frequency use	3 months
If there is smoke	Replace the filter immediately



3. Tips

1

The filter element is a consumable item and needs to be replaced regularly.

2

The filter element replacement cycle is not the quality shelf life of the product.

3

Due to different use scenarios and frequency of use, the filter element replacement cycle varies. The specific use is based on the actual use.

4

Replace the filter element in a timely manner to ensure that the smoke filter reaches the best working state.

Chapter 4

Warranty and Declaration



About this chapter

This chapter is about the warranty and declaration of the machine

Warranty and Declaration	4-1
Design Change	4-2
Warranty	4-3
Declaration of Conformity.....	4-4
Installation Risk Assessment.....	4-5
Machine Risk Assessment	4-7
Parts Diagram	4-9

1. Design Change

With the policy of constant improvement and/or modification to meet changing conditions, the right is reserved to change the design and/or specifications at any time without prior notification, and therefore specifications may vary and not be in accordance with this manual.

1. Guarantee (Limited Warranty)

Adkins warrants that the machine is free from defects in material and workmanship for a period of 12 months from the date of supply. The machine comes with a one-year warranty on parts.

This warranty covers all parts to repair the defects, except when damage results from misuse or abuse, accident, alteration or negligence or when a machine has been improperly installed.

If a machine is covered by warranty should need to be returned to the factory for examination and repair, if on-site component replacement is not possible Adkins will make every effort to repair the customers machine. The warranty will only be effective when Adkins authorises the original purchaser to return the machine to the factory and only when the product upon examination has proven to be defective.

Should in our opinion any part of this machine be defective in materials or workmanship, it will be replaced or repaired free of charge, provided that the press has been installed and operated in the correct manner and not subjected to misuse. In exceptional circumstances If Adkins authorise a replacement machine, the warranty of the replacement machine shall expire on the anniversary date of the original machines invoice to the customer.

In order for this warranty to be effective, no return of machine or parts may be made without prior factory authorisation. (This will exclude any travelling and/or carriage costs which will be charged at our discretion).



This is the sole warranty given by the company; there are no warranties, which extend beyond the description on the face hereof. The seller disclaims any implied warranty of merchantability and/or any implied warranty of fitness for a particular purpose; the buyer agrees that the goods are sold "as is". The sole purpose of the machine is to be used for DTF, outside of this use Adkins does not warrant the machine. The entire risk as to use, quality and performance of the machine lies with the customer. (No claim of any kind shall be greater than the sale price of the product or part to which the claim is made).

In no event will Adkins be liable for any injury, loss or damage, including loss of profits, destruction of goods or any special, incidental, consequential or indirect damages arising from the use of the machine or accompanying materials. This limitation will apply even if Adkins or its authorised agent had been advised of the possibility of such damage.



HEAT PRESS TECHNOLOGY

CHARTERHOUSE HOLDINGS PLC DECLARATION OF CONFORMITY

Application of Council Directives:	European Low Voltage Directive (LVD), European Machinery Directive (MD), Electro Magnetic Conformity (EMC)
Standards to which Conformity is Declared:	(LVD): EN 60204-1:2018 (MD): EN ISO 12100:2010 2006/42/EC Annex1 (EMC): EN 61000-6-2:2019
Manufacturer's Name:	Charterhouse Holdings Plc
Manufacturer's Address:	Oakridge Park, Trent Lane, Castle Donington, Derby DE74 2PY United Kingdom.
Type of Equipment:	DTF Curing Oven
Standards Compliance:	 
Model Number:	DTF Pro Cure Oven
Serial Number:
Year of Manufacture:

I, the undersigned, hereby declare that the equipment specified above conforms to the above directives and standards.

Place: Castle Donington, United Kingdom

Signature: *M. S. Carter*

Date: 19th August 2024

Full Name: Miles Carter
Position: Chief Executive

INSTALLATION RISK ASSESSMENT

Area / Task for assessment: Installation of Adkins DTF Pro Cure Oven with built in extraction

The guidance contained within this prepared assessment form will provide recommendations and indicate what action should be taken where hazards are identified.

Hazards Identified	Persons at risk and how	Manufacturer recommended control measures	Current risk			Recommended action necessary
			L	C	S	
Trip and slip	Persons installing machine – Could slip, trip, fall when moving/lifting goods	Engineer visually checks environment and has adequate PPE.	1	3	3	Persons receive sufficient training Keep environment around the machine tidy
Manual handling	Persons installing machine – Improper lifting techniques.	Training in manual handling techniques. Weights and dimensions listed within product manual. Recommended personnel required to lift details within user manual.	1	3	3	Persons be trained in manual handling techniques.
Electric shock	Persons installing machine – Shock from electrical circuit boards.	Isolate power supply if needed. Caution signage on display . Screw locked cover for electrics.	1	5	5	Persons be trained sufficiently in electrical safety and locations of highest risk of electric shock.
Exposure to harmful isocyanates	Persons installing machine – use of DTF powder risks exposure to isocyanates.	Training in the risk of exposure to isocyanates and sufficient product knowledge. PPE worn when necessary. Relevant H&S signage in place and/or explained in operator's manual.	2	4	8	Ensure that there is appropriate PPE at all times and that staff adhere to any applicable procedures.
Burns	Persons installing machine – burns from heat element and exposure.	Caution signage on display and explained in operator's manual. Protection from heat elements in place.	2	4	8	Ensure provision of a burns kit.
Moving parts	Persons installing machine – risk of injury or loss of limbs from moving parts.	Majority of moving parts are covered, meaning exposure is minimised.	1	4	4	Persons be trained sufficiently and adhere to any applicable procedures.

Risk Level	LCS Risk Score	Average Risk Score	5.17
LOW	< 8.00		
MEDIUM	8.00-14.99		
HIGH	> 14.99		
		Overall Risk Rating	LOW

‘CURRENT RISK’ LCS SCORE SCHEME

Overall Risk		Likelihood				
Consequence		1 (Improbable)	2 (Unlikely)	3 (Possible)	4 (Likely)	5 (Almost Certain)
1 (Negligible)	LOW	LOW	LOW	LOW	LOW	LOW
2 (Minor)	LOW	LOW	LOW	LOW	MEDIUM	MEDIUM
3 (Moderate)	LOW	LOW	LOW	MEDIUM	MEDIUM	HIGH
4 (Major)	LOW	LOW	MEDIUM	MEDIUM	HIGH	HIGH
5 (Catastrophic)	LOW	LOW	MEDIUM	HIGH	HIGH	HIGH

The overall score (Score (S)) is determined by multiplying the Likelihood (L) and the Consequence (C) for each Hazard Identified and taking the average score. A Score (S) below 8.00 is considered a low overall risk; a Score (S) between 8.00-14.99 is considered a medium overall risk; and a Score (S) above 14.99 is considered a high overall risk.

‘Current risk’ scores and the ‘Current risk’ LSC Score Scheme are only suggested by Adkins* and encourage all users to perform their own risk assessment based on their specific environment and circumstances.

Adkins* does not take responsibility for any action (or non-action) taken as a result of adhering or not adhering to recommendations listed in the ‘Recommended further action’ section.

Adkins* does not take responsibility for any consequence arising from actions in the ‘Recommended further action’ section, including death or injury through negligence.

*Adkins is a division of and trades as Charterhouse Holdings plc, Oakridge Park, Trent Lane, Castle Donington, DE74 2PY, United Kingdom.

MACHINE USAGE RISK ASSESSMENT

Machine assessed: Adkins DTF Pro Cure Oven with built-in extraction

The guidance contained within this prepared assessment form will provide recommendations and indicate what action should be taken where hazards are identified.

Hazards Identified	Persons at risk and how	Manufacturer-implemented control measures	Current risk			Recommended further action
			L	C	S	
Electric shock	Persons working with machine – Shock from electrical circuit boards.	Emergency Stop Button. Screw locked cover for electrics. Caution signage on display.	1	5	5	Users be trained suitably in locations of highest risk of electric shock.
Manual handling	Persons working with machine – Improper lifting techniques.	Lockable wheels fitted to aid with movement of machine. Installation ramps included for ease of removing from pallet.	1	3	3	Users be trained in manual handling techniques.
Exposure to harmful isocyanates	Persons working with machine – use of DTF powder risks exposure to isocyanates.	Built-in extraction system for filtration of isocyanates. Cover placed over the powder trough. Outlined the risk of exposure to isocyanates. Relevant H&S signage in place and explained in operator's manual.	2	4	8	Ensure that there is appropriate PPE at all times. Users be trained suitably and adhere to any applicable procedures.
Burns	Persons working with machine – burns from heat element and exposure.	Caution signage on display and explained in operator's manual. Protection from heat elements in place.	2	4	8	Ensure provision of a burns kit.
Moving parts	Persons working with machine – risk of injury or loss of limbs from moving parts.	Majority of moving parts are covered, meaning exposure is minimised. Caution signage on display and explained in operator's manual.	1	4	4	Users be trained suitably and adhere to any applicable procedures.

Risk Level	LCS Risk Score	Average Risk Score	5.60
LOW	< 8.00		
MEDIUM	8.00-14.99		
HIGH	> 14.99	Overall Risk Rating	LOW

‘CURRENT RISK’ LCS SCORE SCHEME

		Likelihood (L)				
Overall Risk	Score (S)	1 (Improbable)	2 (Unlikely)	3 (Possible)	4 (Likely)	5 (Almost Certain)
Consequence (C)	1 (Negligible)	LOW	LOW	LOW	LOW	LOW
	2 (Minor)	LOW	LOW	LOW	MEDIUM	MEDIUM
	3 (Moderate)	LOW	LOW	MEDIUM	MEDIUM	HIGH
	4 (Major)	LOW	MEDIUM	MEDIUM	HIGH	HIGH
	5 (Catastrophic)	LOW	MEDIUM	HIGH	HIGH	HIGH

The overall score (Score (S)) is determined by multiplying the Likelihood (L) and the Consequence (C) for each Hazard Identified and taking the average score. An Score (S) below 8.00 is considered a low overall risk; a Score (S) between 8.00-14.99 is considered a medium overall risk; and a Score (S) above 14.99 is considered a high overall risk.

‘Current risk’ scores and the ‘Current risk’ LSC Score Scheme are only suggested by Adkins* and encourage all users to perform their own risk assessment based on their specific environment and circumstances.

Adkins* does not take responsibility for any action (or non-action) taken as a result of adhering or not adhering to recommendations listed in the ‘Recommended further action’ section.

Adkins* does not take responsibility for any consequence arising from actions in the ‘Recommended further action’ section, including death or injury through negligence.

*Adkins is a division of and trades as Charterhouse Holdings plc, Oakridge Park, Trent Lane, Castle Donington, DE74 2PY, United Kingdom.

Parts Diagram

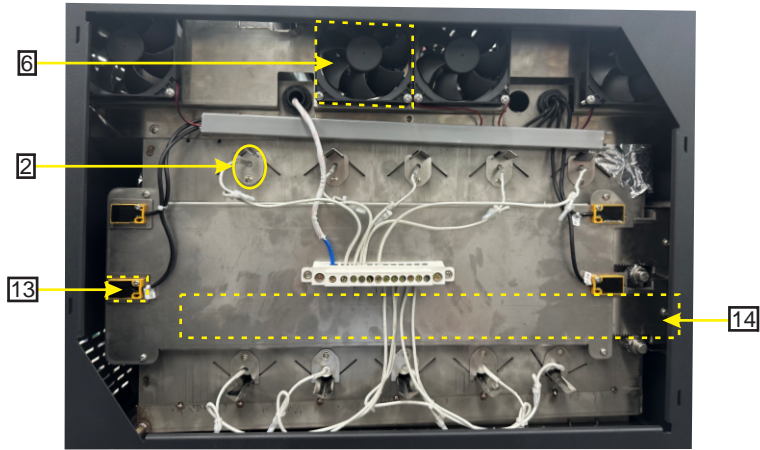
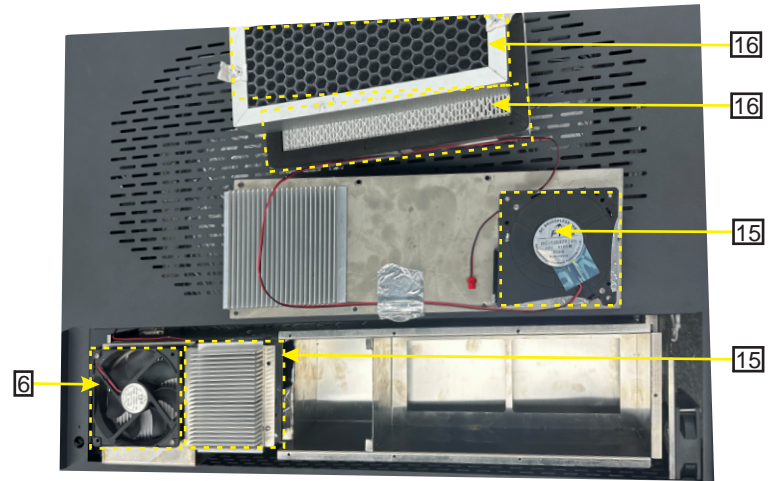
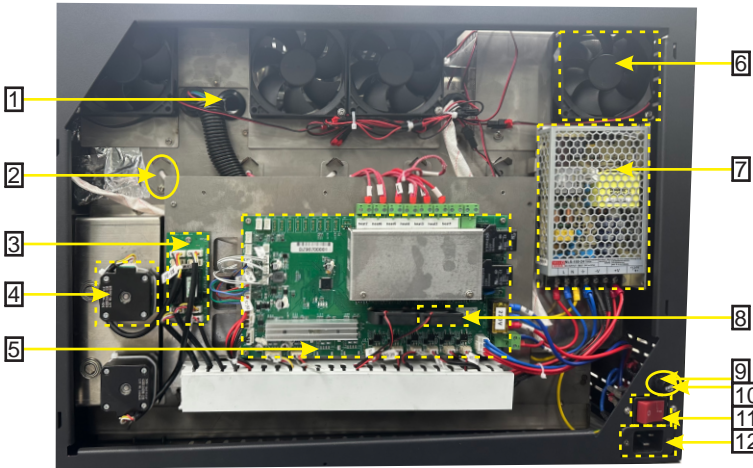

Diagram Number	Part Code	Adkins Basic Description	Amount Per Machine
1	1201-05-08-012-C	Thermowire	1
2	XR-01-044	Heat Element	10
3	EE-15-067-A	Small Board	1
4	42HSC4409B-23B	Tray Motor	2
5	EE-15-066-A	Main Control Board	1
6	7101-11-09-003	Cooling Fan (0.2a)	9
7	EE-26-003-D	24v Power Supply (6.5a)	1
8	XR-51-016A	Control Board Cooling Fan (0.12a)	2
9	EE-51-016-B	Fuse Holder	1
10	EE-51-016-C	Fuse (15amp)	1

Diagram Number	Part Code	Adkins Basic Description	Amount Per Machine
11	7101-11-06-022-C	Power Switch	1
12	XJHC-CZ-011	Power Socket	1
13	XR-01-024	Tray Sensor	4
14	D10-B-005-10	Fixed/Toothed Oven Rail (Left or Right)	4
15	EE-25-009-A	Paper Suction Fan (1.2a)	2
16	XR-01-015	Mini Filter	1
16	XR-01-016	Mini Carbon Filter	1
17	AF-20-09-023A	Digital Touch Screen	1
18	AF-17-09-339A	Emergency Stop Button	1
19	D10-A-005	Tray Handle	2
20	XR-01-008	Tray Rail (Left or Right)	4