

ADKINS

Studio Versa



Operators Handbook

©2015 a.adkins and sons limited. all rights reserved

Preface

Dear User

Welcome to the growing group of Studio Versa Press users. The product you have purchased has been carefully designed and manufactured to ensure that you, the user, will gain the maximum benefit.

All A. Adkins & Sons Limited products are specifically designed to ensure ease of use with particular attention to safety requirements.

Should you discover any fault or damage upon receipt of this product, you should immediately contact your supplier.

Contents

1.	Introduction Studio Versa Press	1
1.1	Specifications of the Studio Versa Press	2
1.2	Safety	3
2.	Installation	5
2.1	Transport instructions	5
2.2	Installing the machine	5
2.3	Electrical requirements	5
2.4	Adjusting the pressure	6
3.	How to operate the Studio Versa Press	8
3.1	Starting with the Studio Versa Press	8
3.2	Working with heat transfer materials	8
3.3	Standard T-shirt attachment removal/refitting	10
3.4	Optional Cap attachment removal/refitting	11
3.5	Optional Plate attachment removal/refitting	13
3.6	Optional Mug attachment removal/refitting	14
3.7	Heater Pad Assembly	17
4.	Maintenance of the Machine	18
4.1	Periodic maintenance	18
4.2	Cleaning	18
5.	Machine Drawings and Diagrams	19
5.1	General Layout of the Studio Versa Press	20
5.2	Operation of the Control Unit	21
5.3	Exploded Diagram and Parts List	22
5.4	Electrical Diagram	23
6.	Design Change	24
7.	Guarantee (Limited Warranty)	25
	Declaration of Conformity	26

1. Introduction Studio Versa Press

The Studio Versa Press has been designed for flexibility and ease of operation, with the standard configuration setup for T-shirts and optional configurations also available for Caps, Mugs and Plates for an additional charge.

This simple robust machine is powered by a microprocessor for control of both heat and dwell accuracy and ease of operation requiring minimal operating space.

The Studio Versa Press is produced to be nominally 230-240 Volts AC.

1.1 Specifications of the Studio Versa Press

The Studio Versa Press is a manually operated heat press for transfer printing. It is ideal for small/ medium volume production.

The work area of the Studio Versa Press is 60 x 80 cm.

Specifications

European Machine

Power consumption	1325 Watts
Power supply	230 Volts AC
Maximum Working temperature	260°C
Display Timer Range	0 - 9999 sec
Machine height open	55 cm
Machine width	39 cm
Machine depth	43 cm
Net weight (inc. plates)	22.5 kg
(Standard) T-shirt pad dimensions	38 x 30 cm
(Optional) Cap pad dimensions	15 x 8 cm
(Optional) Plate pad dimensions	Ø12 cm
(Optional) large Mug pad dimensions	22.5 x 11 cm
(Optional) standard Mug pad dimensions	20 x 11 cm
Fuses	5.75 A

1.2 Safety

- ◆ **Our customer service department** has its own service engineers and, if required, maintenance and advice is available.
 - ◆ **The Studio Versa Press** meets the European Legislation standard. Under normal conditions accidents are rare, however listed below are some practical points to ensure your safety.
 - **Always switch off** the mains supply (and pull plug out of the socket) when undertaking maintenance work or when cleaning the machine.
 - **Ensure that there is** sufficient space around the machine. Cables and connections must not get jammed. Although the heat radiation of the press is low, there should be enough space for cooling down.
 - **Avoid contact** with the presses elements.
 - ◆ **DO NOT REMOVE THE COVER OR CONTROLLER UNLESS QUALIFIED TO DO SO** - touching internal parts is dangerous and may cause shock hazard. All electrical connections inside covers are live. Never operate Press with any covers and/or guards removed.
 - ◆ **PROTECT THE MAINS CABLE** - Damage to the mains cable may cause fire or shock hazard. When unplugging, hold by the plug only and remove carefully. Take care that the mains cable does not come into contact with any heating elements (or moving parts of the mechanism) during operation of the machine.
 - ◆ **OPERATING AMBIENT TEMPERATURE RANGE** - the operating ambient temperature range is 32°F - 104°F, (0°C - 35°C) and humidity of 20 - 80%.
 - ◆ **MACHINE FUSES** - type: 5.75 Amps
 - ◆ **WARNING - THIS APPARATUS MUST BE EARTHED (GROUNDED)**
 - ◆ **CAUTION**

This machine gets hot whilst operating. Take care not to touch any surfaces that are labelled “Caution HOT”. **Keep hands away from heating elements**
 - ◆ **MACHINE OPERATION**

Only persons trained to do so should operate this machine.

This machine is designed to be operated by one operator only.
-

Safety (Cont.)

- ◆ **The (optional) large and standard Mug pressing pads** should remain in the unclamped position when not in use. When in use, **NEVER** close the machine into the clamped position without a mug inserted into the element as this will destroy the heating element and negate the warranty.
- ◆ **Contact your print media suppliers** to ascertain whether fumes are given off during the transfer process and if so what precautions are needed for operator safety. These may include air extraction and/or masks for personnel.

Please refer to Page 20 for an illustration of the Studio Versa Press machine.

2. Installation

2.1 Transport instructions

The machine comes to you in a box or shrink-wrapped. If you have to transport the machine at any time it is recommended that you use a similar box and packing methods. Please let the machine cool down and move the handle to the locked position.

N.B. **Never move the machine** with an (optional) large or standard Mug pressing pad in place, unless a correctly fitting mug is clamped into the printing position.

2.2 Installing the machine

2.2.1 Remove all packaging from the heat press.

2.2.2 Check to ensure that no damage has been caused to the machine during transit.

2.2.3 Place the machine on a sturdy horizontal surface that is within easy reach of the operator and allow space for the handle to move to the loading position. Ensure that no items vulnerable to heat radiation are too close to the machine.

2.2.4 IMPORTANT: Ensure that the machine is secured to the work surface with the brackets provided on the front and rear of the machine. (See Technical Support leaflet supplied with press).

2.2.5 Attach heat plate power lead and plug to control box socket. (See Technical Support leaflet supplied with press).

2.3 Electrical requirements

The Studio Versa Press should be connected to the mains supply, (nominally 230V AC for the European Market), by the mains cable provided and a suitable plug.

The press is designed for 230Volts AC 50/60 hertz and requires exclusive use of a power outlet rated for at least 3.15Amps (Europe).

Ensure that the supply rating on the machine specification plate corresponds with your local supply and that the correct plug is fitted.

2.3.1 Wiring the plug for a 230V AC Machine

The wires in this mains lead are coloured in accordance with the following code:

Electrical requirements (Cont.)

Green and Yellow:	EARTH
Blue:	NEUTRAL
Brown:	LIVE

As the colours of the wires in the mains lead of this apparatus may not correspond with the coloured markings identifying the terminals in your plug, proceed as follows:-

1. **The wire coloured green and yellow** must be connected to the terminal in the plug, which is marked by the letter E, or by the safety earth symbol coloured green, or green and yellow.
2. **The wire, coloured blue** must be connected to the terminal which is marked with the letter N, or coloured black.
3. **The wire, coloured brown** must be connected to the terminal which is marked with the letter L, or coloured red.

NOTE:

A competent service engineer must carry out any replacement of the mains cable.

HEATING ELEMENTS

The heating elements fitted to this press are rated at 1325 Watts/230V AC.

Never connect to any outlet or power supply having a different voltage/frequency from that on the machine data plate.

2.4 Adjusting the pressure

This pressure is altered with the black pressure adjustment knob located on the top of the machine:

- a) **To increase pressure** or to use smaller diameter mugs turn knob clockwise.
- b) **To decrease pressure** turn the adjustment knob anticlockwise.
- c) **Be careful when placing a mug in the press**, fitted with the (optional) large or standard Mug pressing pad, that the pressure jaws are not in contact with the mug handle as this may cause damage to the element.

NOTE

DO NOT adjust the pressure when the machine is clamped shut

CAUTION

Never increase the pressure to the extent of requiring undue force to lower the operating handle into the lock position, as this will place excessive stress on the pressing pads, resulting in damage to the press.

Please refer to Page 21 showing the operation of the control unit.

3. How to Operate the Studio Versa Press

3.1 Starting with the Studio Versa Press

3.1.1 Plug into your supply outlet and switch supply on.

N.B. Please ensure the mains plug is easily accessible to the operator so that in the event of a fault the machine can be unplugged.

3.1.2 Turn on the Studio Versa Press; the on/off rocker switch is on the back of the machine cover and illuminates when “on”. Set the machine controls as necessary. See instructions for adjusting the pressure 2.4, and the operation of the time temperature unit 5.2.

3.2 Working with Heat Transfer Materials

First ascertain from the supplier of the garment/ cap/ plate/ mug that they are suitable for transfer printing and obtain from them and from the transfer supplier the correct heat and time dwell setting for the process. Always check before use that the transfers are either. ‘Hot’ or ‘Cold’ peel. Approximate settings may be as follows:

3.2.1 (Standard) T-shirt, (optional) Cap, (optional) Plate attachments

- a) **Adjust the pressure** setting of the machine by rotating the adjusting knob situated on the top of the machine (See exploded diagram in this manual) clockwise for more pressure, anticlockwise for less pressure. Place transfer and substrate into machine, positioning it as required. Make any final adjustments using the pressure setting.
- b) **From a cold start-up** allow the press to heat up to the desired temperature.
- c) **To achieve a good transfer result** the transfer paper should be placed in the desired position on the substrate, removing all wrinkles. Set the pressure adjustment so that there is good contact with the substrate.
- d) **When the temperature indicator** on the controller reaches the set value the machine is ready to print. When you are satisfied that the transfer is in the correct position gently close the press with the handle. Immediately press the timer button on top of the control unit to start the pressing cycle.

N.B. The handle must be in the locked position ensuring that the work is fully clamped.

Working with Heat Transfer Materials (cont.)

- e) **When the pressing cycle is completed** and the buzzer sounds press the timer button again to silence the buzzer, then release the handle and raise the heat plate.
- f) **Carefully remove** the substrate from the pressing pad (**it will be very hot**). The transfer can now be carefully removed.
- g) **Please refer** to transfer printer's instructions, to ascertain if the transfer is 'hot' or 'cold' peel.

3.2.2 (Optional) large/standard Mug elements

- a) **Adjust the pressure** setting of the machine by rotating the adjusting knob situated on the top of the machine. (See exploded diagram in this manual). Clockwise for more pressure, anticlockwise for less pressure. It is always best to find the most suitable opening before using the transfers in production. Adjust the position of the Silicone Heating Element, place mug into machine, positioning it as required. Make any final adjustments using the pressure setting.
- b) **From a cold start-up** allow the press to heat up to the desired temperature. Insert a plain mug into the press and close the handle. The mug will absorb a large amount of heat and the temperature will drop, but the element will climb to set temperature within a short time. It is normal for the displayed temperature on the controller to fall by up to 30°C very quickly when a cold mug is placed into the press; however the element is designed to recover up to the set temperature very quickly.
- c) **To achieve a good transfer result** the transfer paper should be placed in the desired position on the mug, securing in place with heat proof adhesive tape and removing all wrinkles. Ensure there is sufficient pressure on the mug for good results. Set the pressure adjustment so that there is good contact with the mug.
- d) **When the temperature indicator** on the controller reaches the set value, the machine is ready to print. Remove the plain mug then place the print mug in position in the press. When you are satisfied that the mug is in the correct position, gently close the press with the handle, taking care that the machine jaws do not catch on the mug handle. Then immediately press the timer button on top of the control unit to start the pressing cycle.

N.B. The handle must be in the locked position ensuring that the work is fully clamped.

- e) **When the pressing cycle is completed** and the buzzer sounds press the timer button again to silence the buzzer, then release the handle and raise the heat plate. The mug should then be released and carefully taken out of the pressing pad (**it will be very hot**). The transfer can now be carefully removed.
-

Working with Heat Transfer Materials (cont.)

- f) **Please refer** to transfer printer's instructions, as in some cases it is recommended you place mug in bowl of cold water before removing transfer paper.

3.3 Standard T-shirt attachment removal/refitting

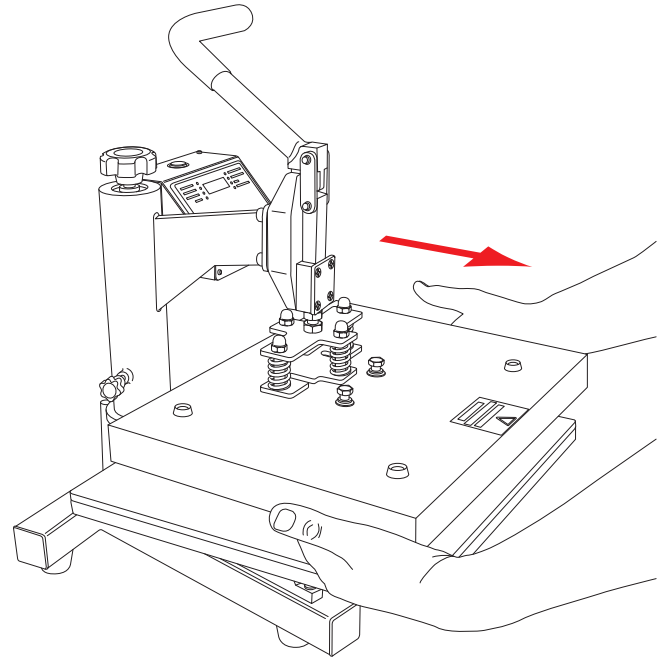
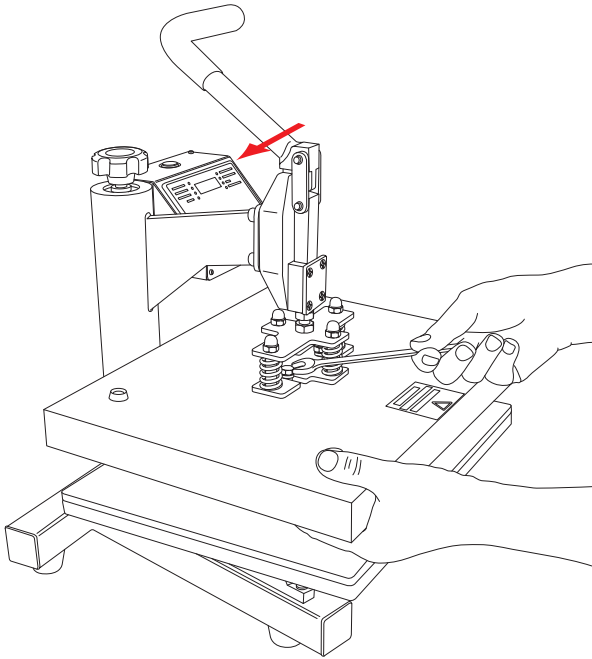

1. Loosen the two table retaining bolts with a 13mm spanner.
2. Detach the 4-pin plug from the control box (see arrow).

3. Slide off the heat plate from retaining bracket.

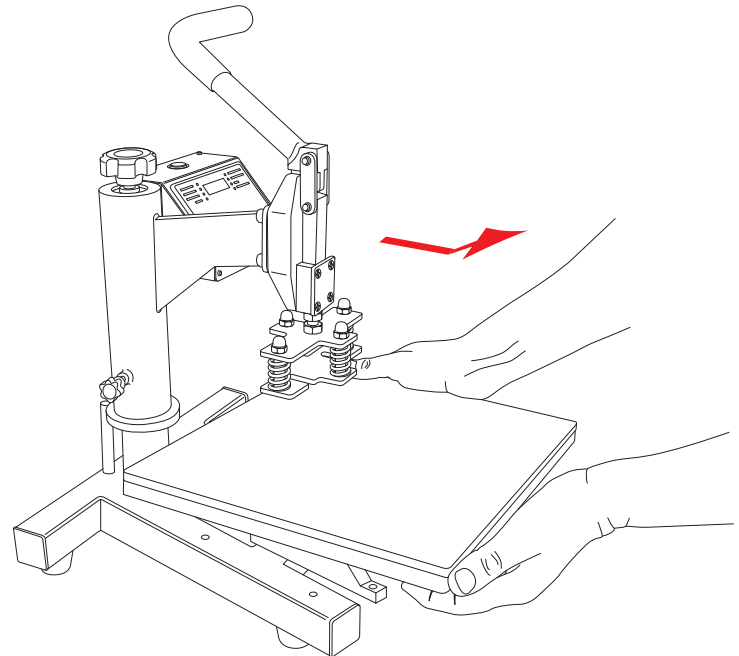
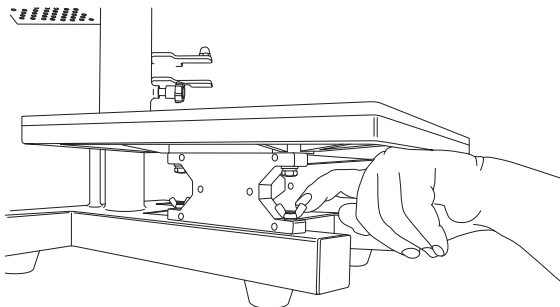

4. Remove the four wing nuts and washers securing the bottom table supports.

5. Slide off the bottom table and table supports.
6. Refitting is a reversal of removal.

3.4 Optional Cap attachment removal/refitting

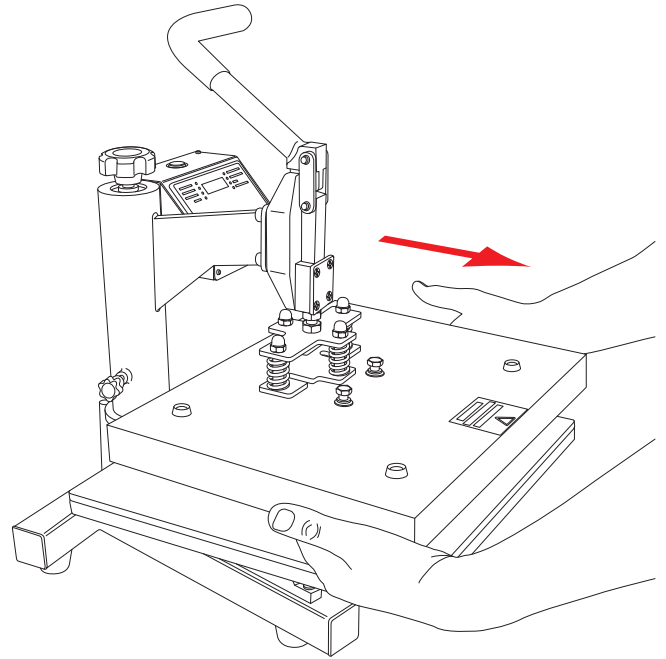
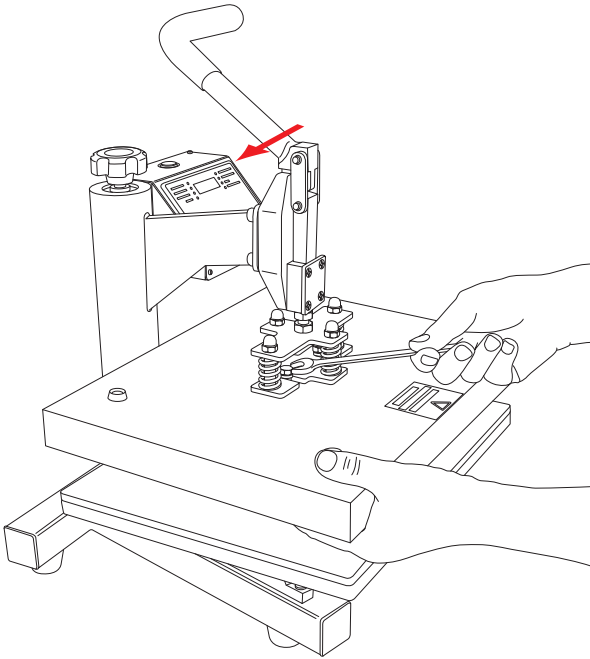

1. Loosen the two table retaining bolts with a 13mm spanner.
2. Detach the 4-pin plug from the control box (see arrow).

3. Slide off the heat plate from retaining bracket.

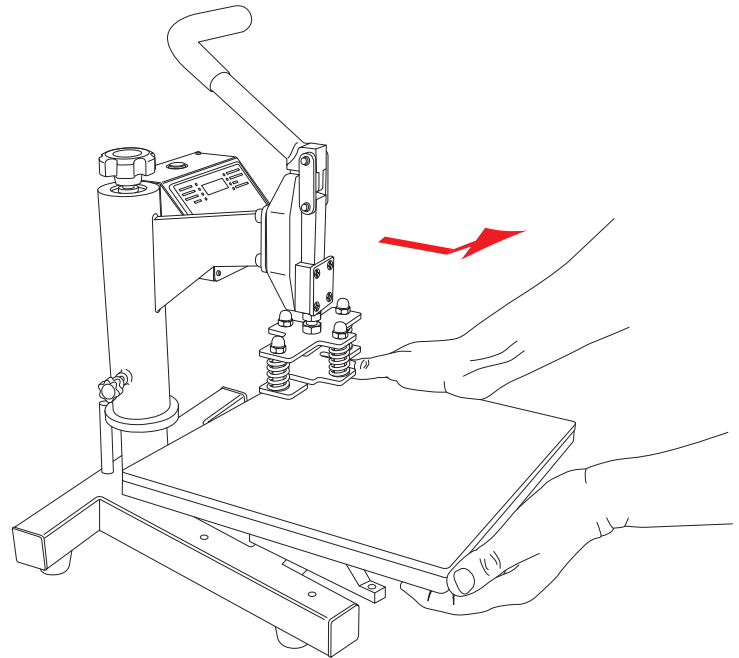
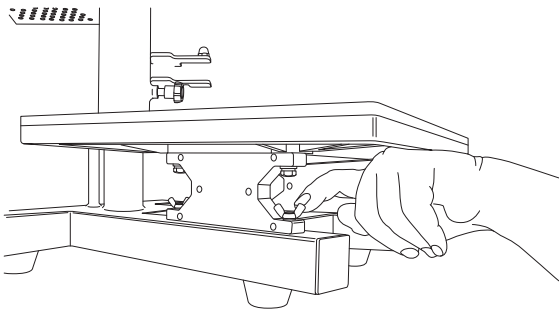

4. Unscrew four wing nuts on bottom table supports.

5. Slide off the bottom table and table supports.

Optional Cap attachment removal/refitting (cont.)

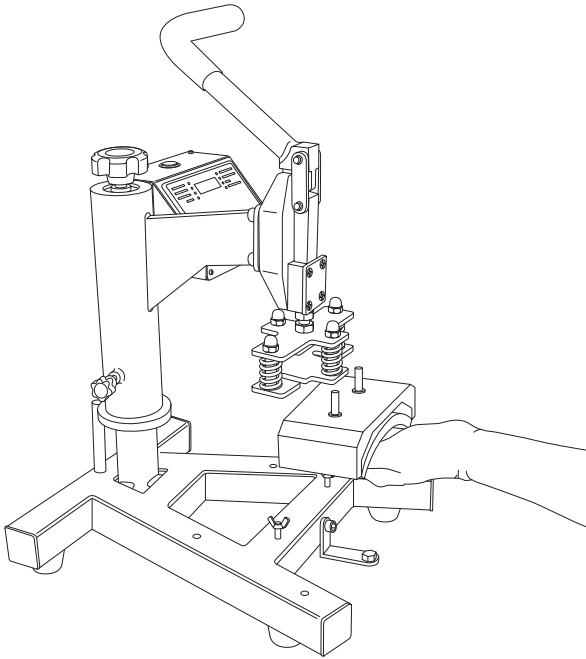

6. Slide heat plate into table bracket taking care to arrange the 4-pin plug to the rear.

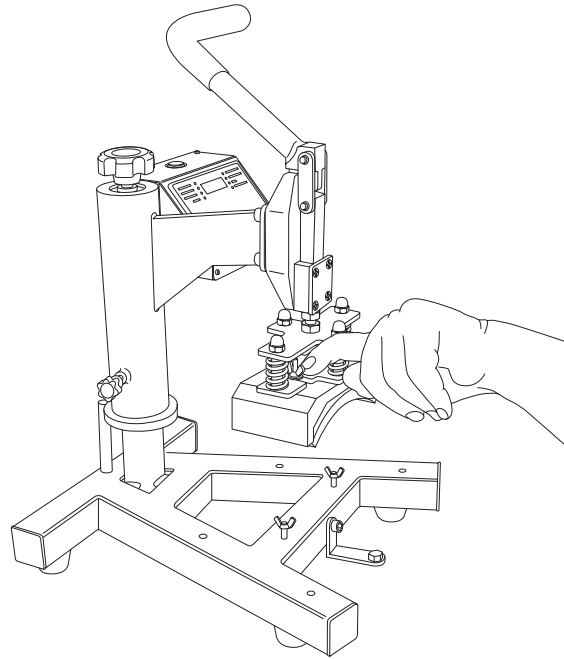

7. Secure heat plate with two wing nuts and washers included and attach the 4-pin plug to the control box.

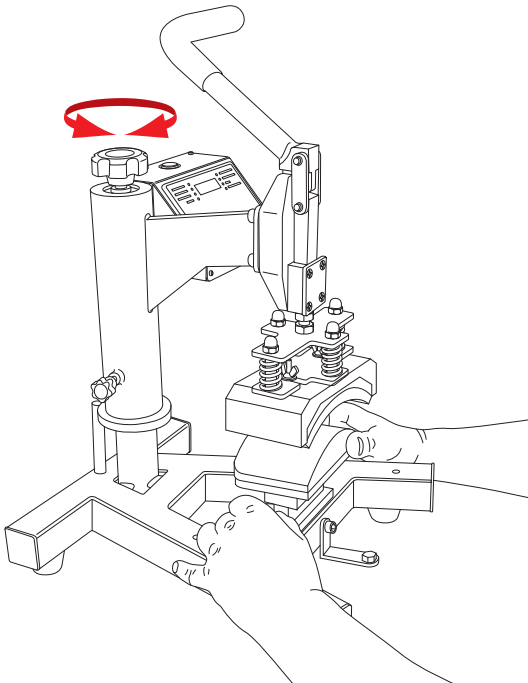

8. Secure bottom table with two wing nuts and washers.

9. Adjust pressure screw to suit item to be transferred (see arrows).

10. Refitting is a reversal of removal.

3.5 Optional Plate attachment removal/refitting

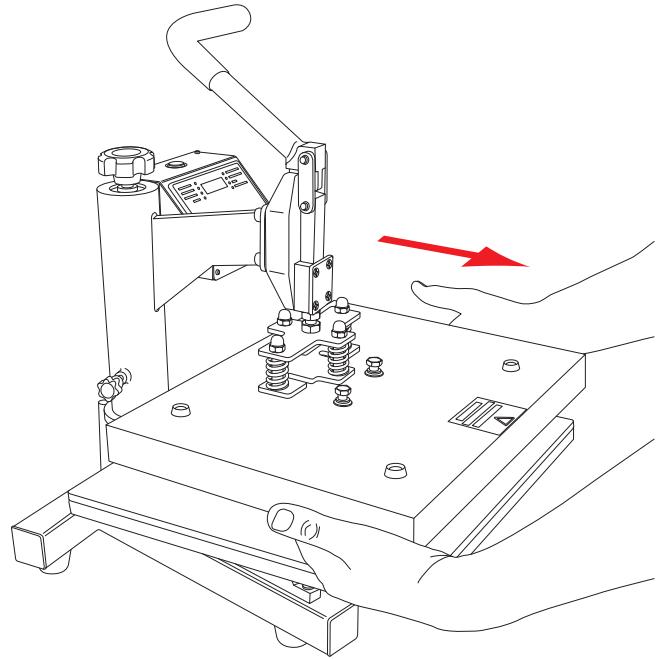
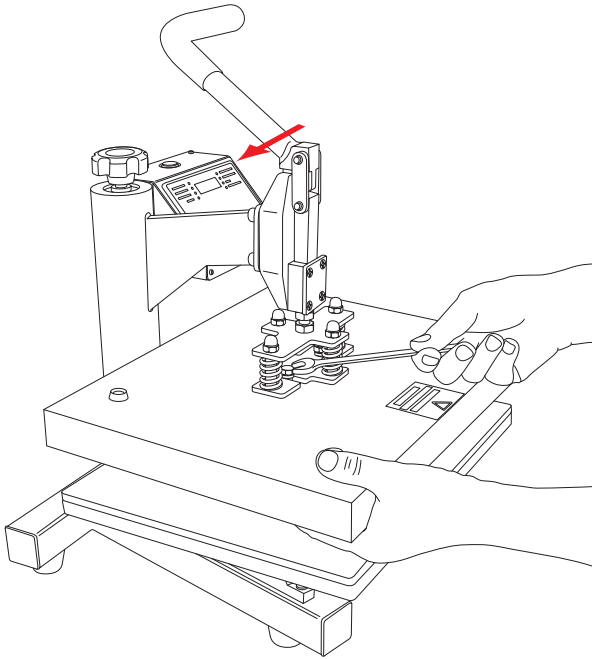

1. Loosen the two table retaining bolts with a 13 mm spanner.
2. Detach the 4-pin plug from the control box (see arrow).

3. Slide off the heat plate from retaining bracket.

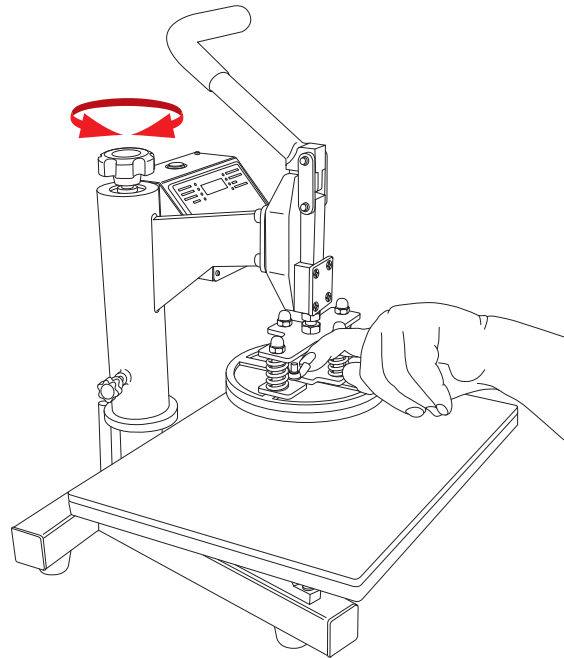
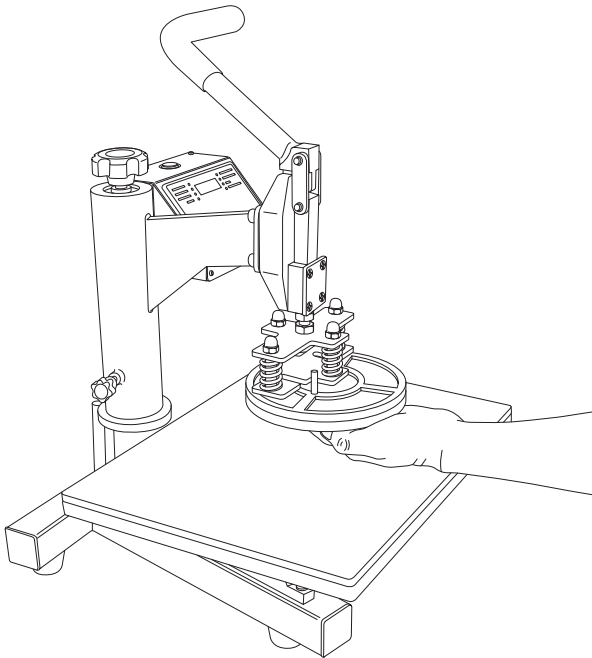

4. Slide plate table into table bracket taking care to arrange the 4-pin plug to the rear.

5. Secure plate table with two wing nuts and washers and attach the 4-pin plug to the control box.
6. Adjust pressure screw to suit item to be transferred (see arrows).
7. Refitting is a reversal of removal.

3.6 Optional Mug attachment removal/refitting

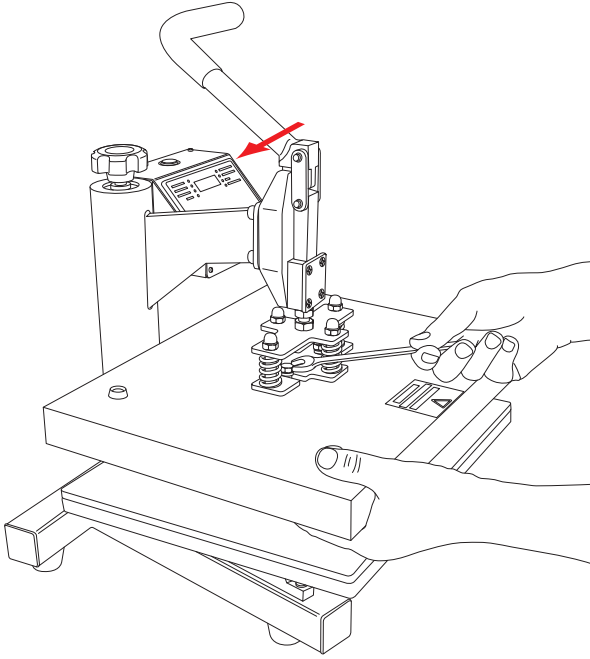

1. Loosen the two table retaining bolts with a 13mm spanner.
2. Detach the 4-pin plug from the control box (see arrow).

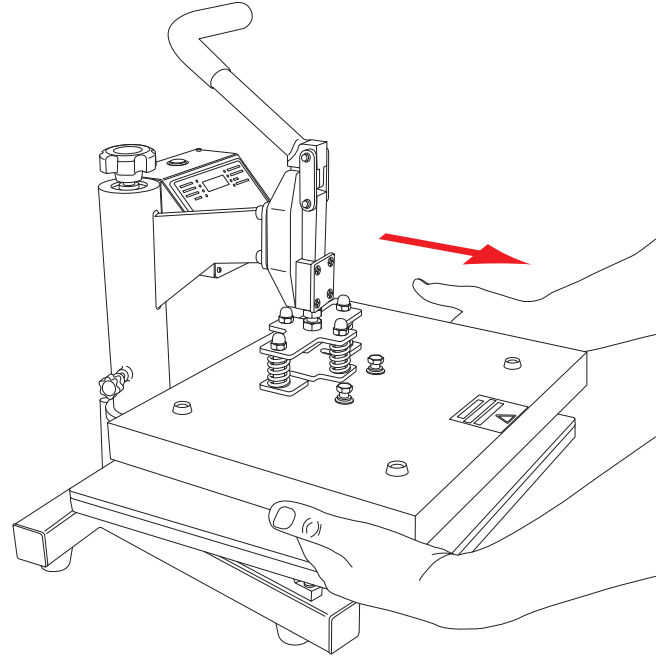

3. Slide off the heat plate from retaining bracket.

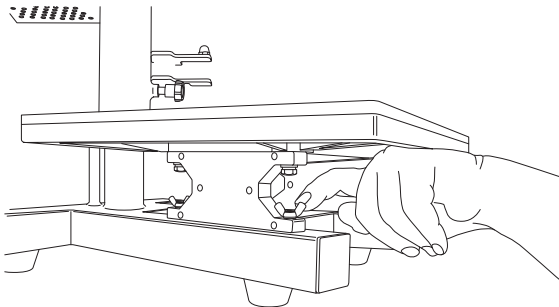

4. Unscrew four wing nuts on bottom table supports.

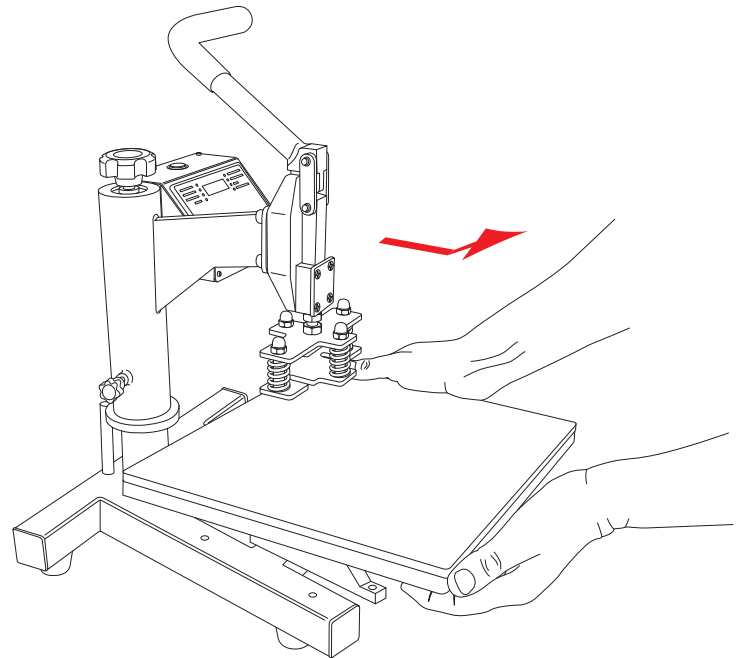

5. Slide off the bottom table and table supports.

Optional Mug attachment removal/refitting (cont.)

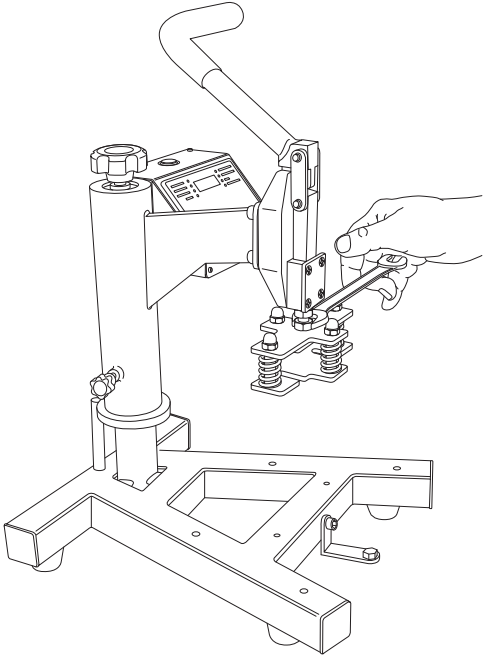

6. Undo top locking nut and remove top bracket with a 17 mm spanner.

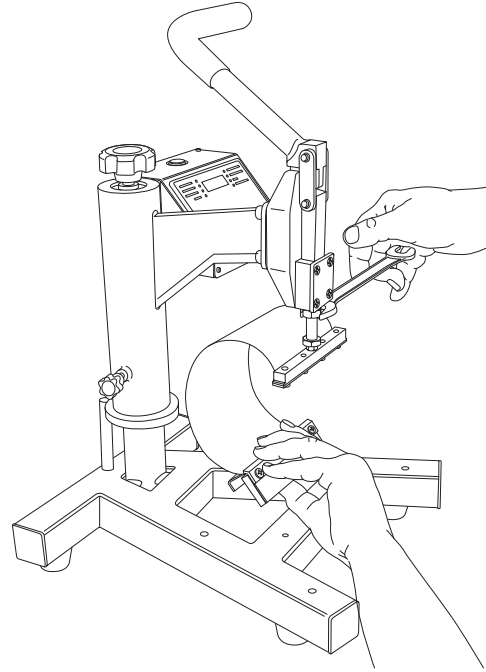

7. Thread the metal tensioning strap into the toggle slide and lock with a 17 mm spanner.

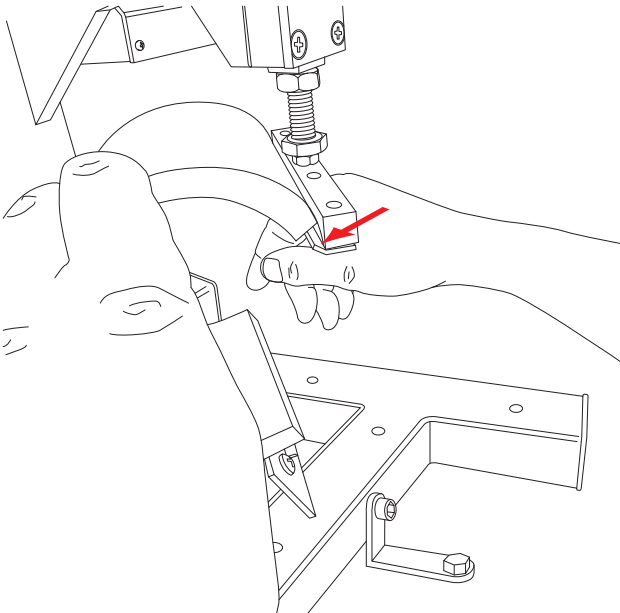

8. Slide the element into the tensioning strap, taking care to slide *gently* under the lip at either end of the tensioning strap (see arrow).

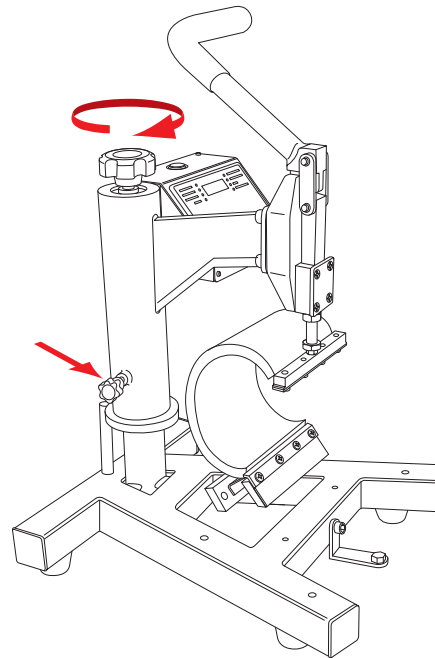

9. Lock the rotational knob to hold press in the dead ahead position (see lower arrow).
10. Turn the pressure screw clockwise so that the base comes into contact with the frame (see top arrow).

Optional Mug attachment removal/refitting (cont.)

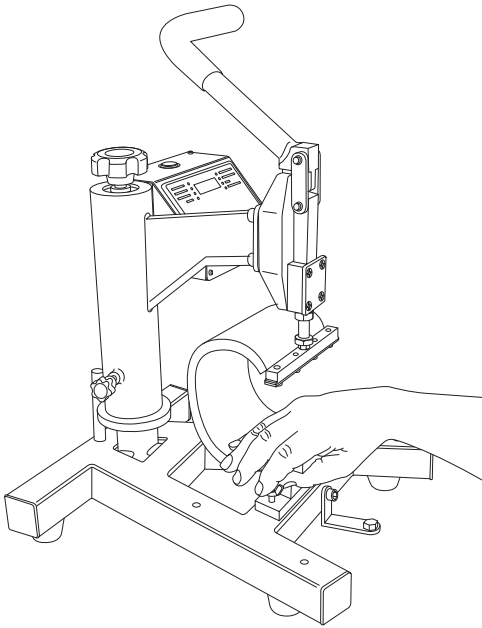

11. Secure the heater band with two wing nuts and washers.
12. Installation is a reversal of removal.

3.7 Heater Pad Assembly

The heater pads fitted to this machine are faced with silicone rubber and a piece of P.T.F.E. sheet, to prevent 'strike-through' of surplus ink back onto the heater element. The pressing surfaces must be maintained in good condition at all times. A worn pressing surface will always affect the quality of printing. Do not insert items into the machine, which could damage the printing surfaces.

4. Maintenance of the Machine

4.1 Periodic Maintenance

CHECK that the heating elements are clean.

Put a few drops of oil onto the various pivot pins and the pressure adjusting screw every three months.

4.2 Cleaning

Clean the outside of the machine frequently with a clean, moist cloth. This may conveniently be carried out before starting when the machine is cool. First unplug the machine.

CHECK that the heating elements are clean and free to clamp easily during pressing operation.

5. Machine Drawings and Diagrams

On the following pages are the schematic diagrams for the Studio Versa Press.

- 5.1 General Layout.....Page 20**
- 5.2 Operation of Control Unit.....Page 21**
- 5.3 Exploded Diagram and Parts List.....Page 22**
- 5.4 Electrical Diagram.....Page 23**

5.1 General Layout of the Studio Versa Press

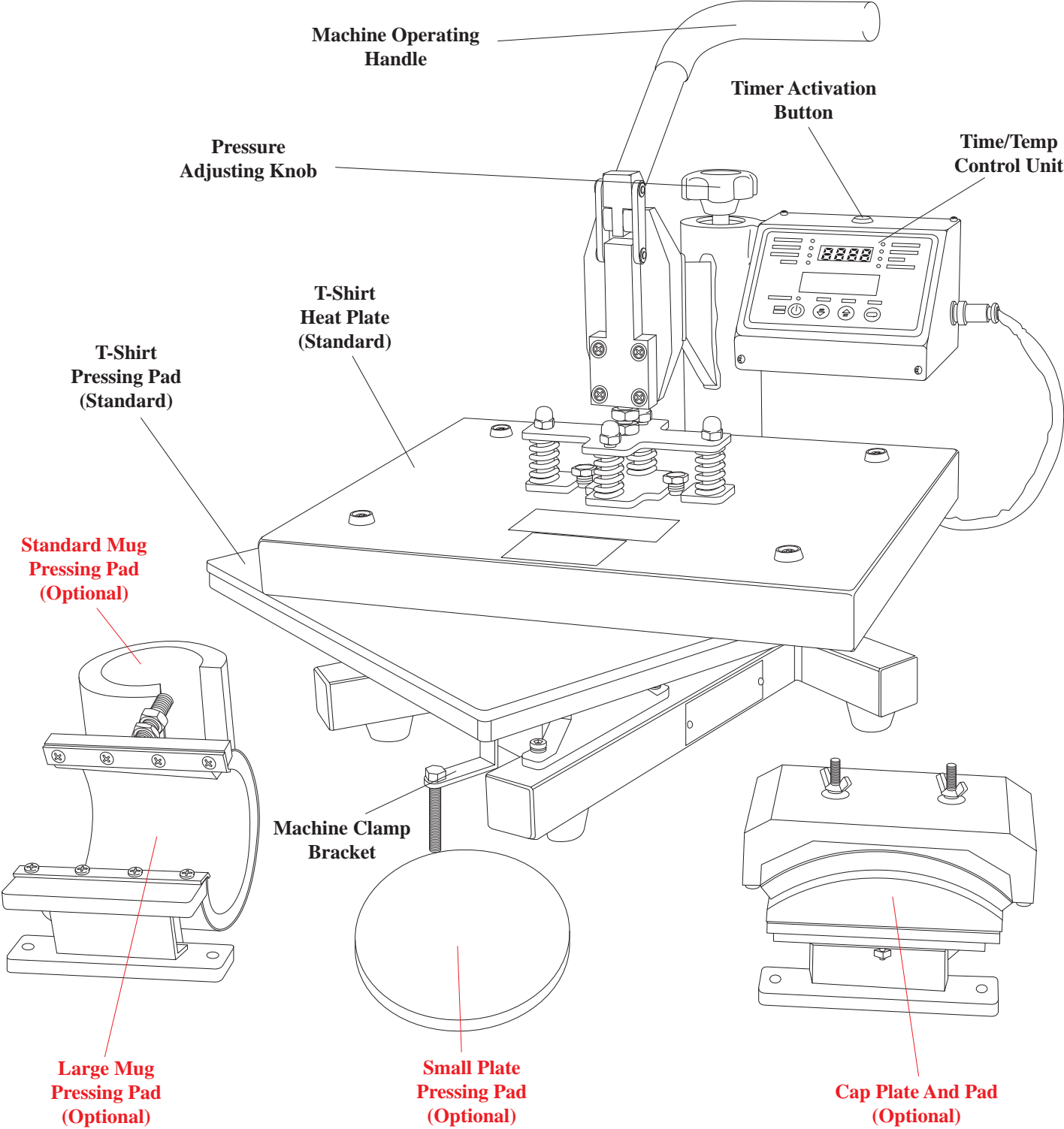

5.2 Operation of Control Unit, setting temperature and time

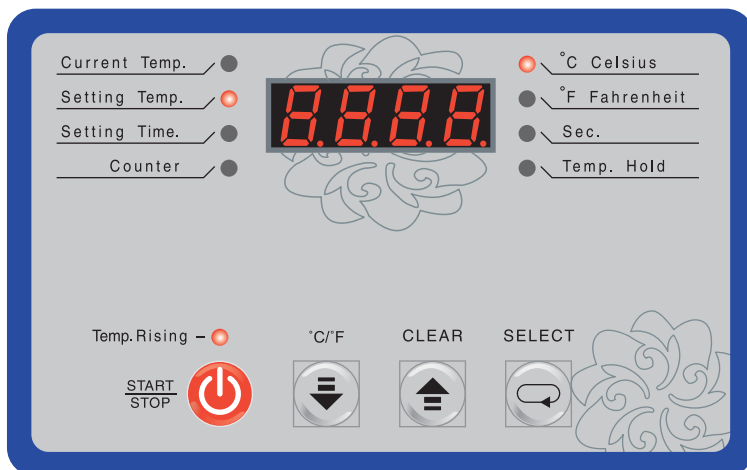

Setting Temperature

1. Switch on machine.
2. Press 'SELECT' button to select 'Setting Temp' on LH indicator.
3. Use the 'up and down' arrow buttons to set the required temperature.
4. Press 'SELECT' button to select 'Current Temp' on LH indicator.
5. Press 'START/STOP' button to start the machine heating to the selected temperature.

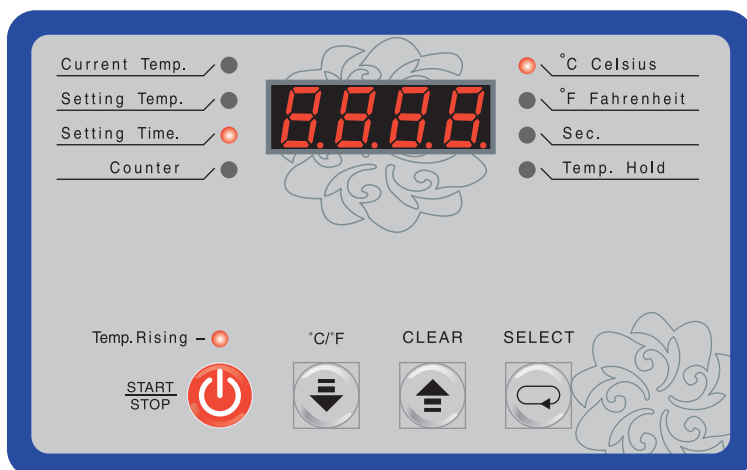

Setting Time

1. Switch on machine.
2. Press 'SELECT' button twice to select 'Setting Time' on LH indicator.
Use the 'up and down' arrow buttons to set the required time.
3. Press 'SELECT' button to select 'Current Temp' on LH indicator.
Press 'START/STOP' button to start the machine.
4. Press 'START/STOP' button to start the machine.
5. Press 'START/STOP' button to start the machine.

Selecting Temperature Format

1. Switch on machine.
2. Press and hold '°C/F' button to select '°C Celsius' or '°F Fahrenheit' on RH indicator.
3. Press and hold '°C/F' button again to toggle between the two temperature formats.

Setting Digital Counter to Zero

1. Press 'SELECT' button three times to select 'Counter' on LH indicator.
2. Press and hold 'CLEAR' button to zero counter.

5.3 Exploded Diagram and Parts List

No.	Description	Qty.	Part No.
1	Pressure adjust knob	1	ASC7
2	Pressure screw	1	SVP2
3	6202ZZ bearing	1	SVP3
4	Fabricated arm	1	SVP4
5	Frame	1	SVP5
6	Controller mounting panel	1	SVP6
7	Plastic housing	1	ASM19
8	Control box	1	SVP8
9	Operating handle	1	SVP9
10	Heat plate mount (upper)	1	SVP10
11	Pressure spring	1	SVP11
12	Heat plate mount (lower)	1	SVP12
13	Insulation cover	1	SVP13
14	1.2 kW heat plate	2	SVP14
15	Silicon pad	1	SVP15
16	(Standard) platen	1	SVP16
17	Platen mounts	4	SVP17
18	(Optional) Ø120 mm heat plate	1	SVP19
19	(Optional) Ø60 mm mug element	1	SVP20
20	(Optional) Ø70 mm mug element	1	SVP21
21	(Optional) cap element	1	SVP22
22	(Optional) cap element kit	1	SVP23*
23	(Optional) mug element band and mounting bracket	1	SVP24
24	Rocker switch	1	BM448
25	Fuse holder	1	ASCL30
26	Fuse 10 Amps	1	ASCL37/A
27	Rubber feet	4	ASM17
28	Locking threaded knob	1	SVP29
29	Controller unit	1	ASM10/N
30	PVC facia	1	ASM18/N
31	Mains lead & plug 230 V (UK)	1	BMC618
	Mains lead & plug 230 V (EU)	1	BMC620
32	Machine clamps	2	SVP589
33	Push button switch	1	SVP33
34	Machine data plate	1	SVP330
35	(Optional) mug element kit	1	SVP25*

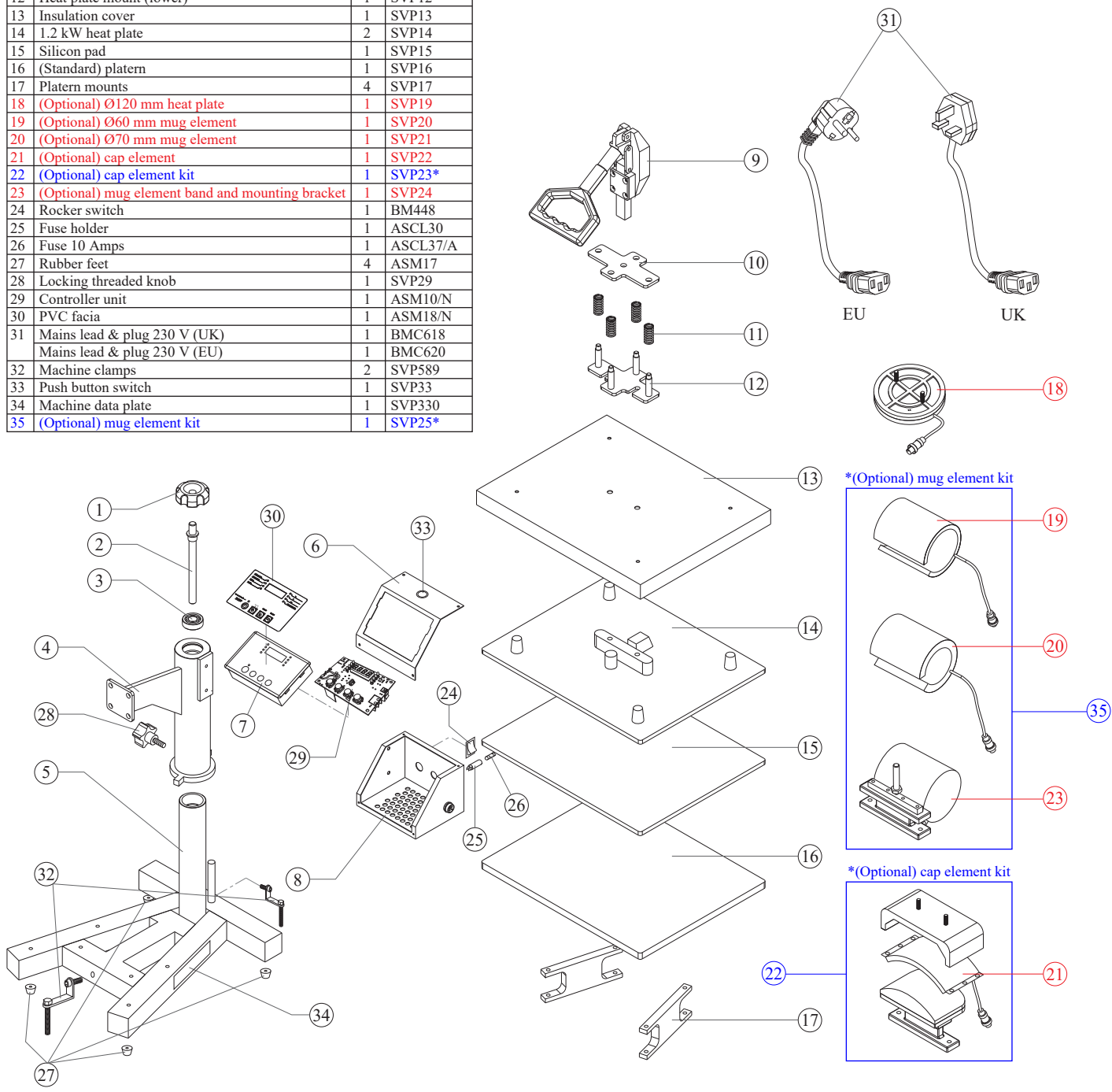

5.4 Electrical Diagram

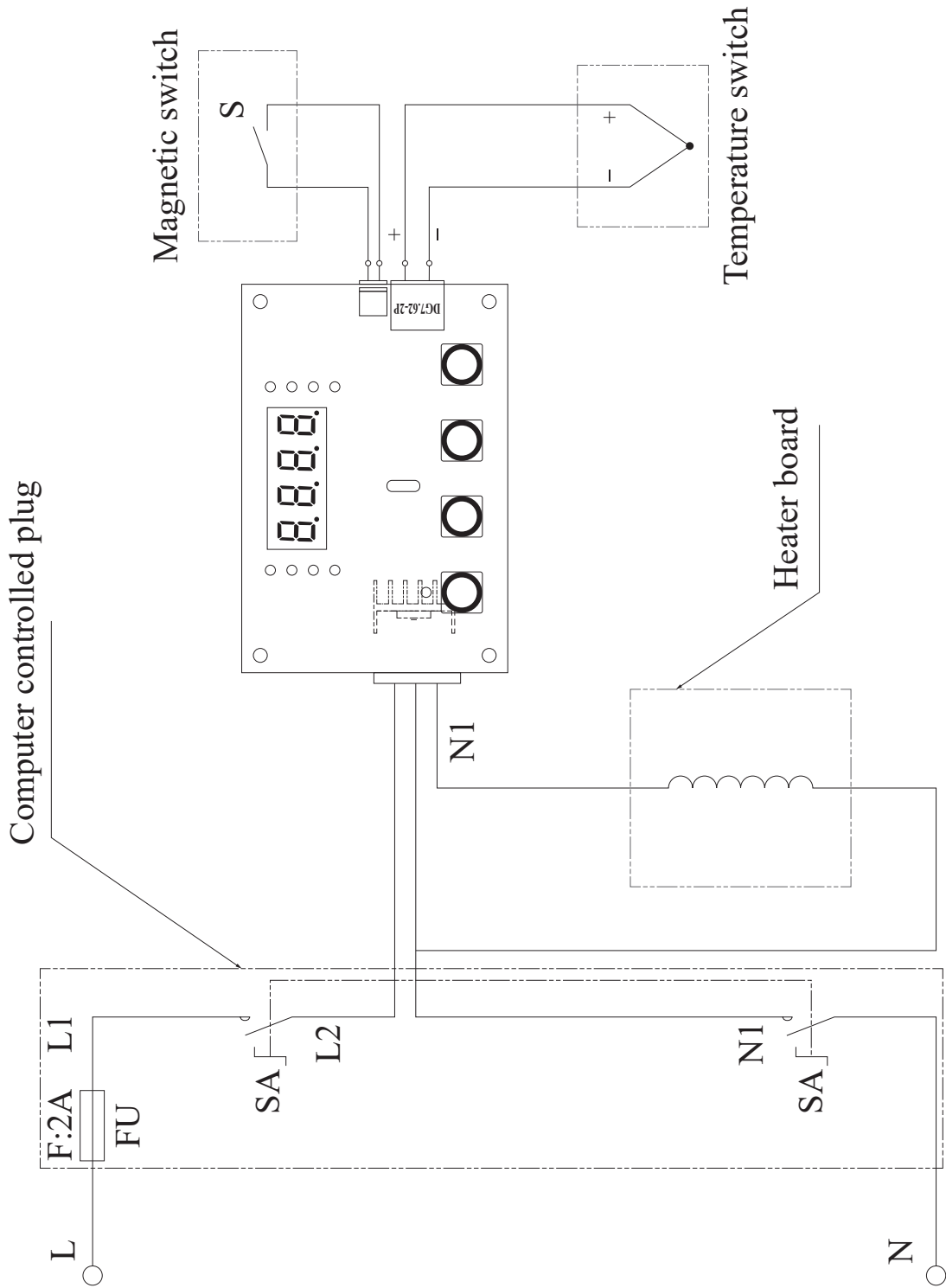

6. Design Change

With the policy of constant improvement and/or modification to meet changing conditions, the right is reserved to change the design and/or specifications at any time without prior notification, and therefore specifications may vary and not be in accordance with this manual.

7. Guarantee (Limited Warranty)

A. Adkins & Sons Limited warrants that the press is free from defects in material and workmanship for a period of 12 months from the date of supply to the customer. The machine comes with a one-year warranty on parts and 90 days labour and a 6 month warranty on heating elements.

This warranty covers all parts to repair the defects, except when damage results from misuse or abuse, accident, alteration or negligence or when a machine has been improperly installed.

If a press covered by warranty should need to be returned to the factory for examination and repair, if on-site component replacement is not possible, A. Adkins & Sons Limited will make every effort to repair the customers press. The warranty will only be effective when A. Adkins & Sons Limited authorises the original purchaser to return the machine to the factory and only when the product upon examination has proven to be defective.

Should in our opinion any part of this press be defective in materials or workmanship, it will be replaced or repaired free of charge, provided that the press has been installed and operated in the correct manner and not subjected to misuse. If A. Adkins & Sons Limited authorise a replacement press, the warranty of the replacement press shall expire on the anniversary date of the original machines invoice to the customer.

In order for this warranty to be effective, no return of machine or parts may be made without prior factory authorisation. (This will exclude any travelling and/or carriage costs which will be charged at our discretion).

This is the sole warranty given by the company; there are no warranties, which extend beyond the description on the face hereof. The seller disclaims any implied warranty of merchantability and/or any implied warranty of fitness for a particular purpose; the buyer agrees that the goods are sold "as is". A. Adkins & Sons Limited does not warrant that the functions of the press will meet the customer's requirements or expectations. The entire risk as to use, quality and performance of the press lies with the customer. (No claim of any kind shall be greater than the sale price of the product or part to which the claim is made).

In no event will A. Adkins & Sons Limited be liable for any injury, loss or damage, including loss of profits, destruction of goods or any special, incidental, consequential or indirect damages arising from the use of the press or accompanying materials. This limitation will apply even if A. Adkins & Sons Limited or its authorised agent had been advised of the possibility of such damage.

A. ADKINS & SONS LIMITED
DECLARATION OF CONFORMITY



<p>Application of Council Directives:</p> <p>Standards to which Conformity is Declared:</p>	<p>Machinery, Low Voltage. E.M.C.</p> <p><u>BS EN ISO 12100:2010</u> - Safety of machinery: Basic Technology, Principles of Design. <u>BS EN 6024-1:2006+A1:2009</u> - Safety of machinery: Electrical Equipment of Machines. <u>BS EN 60529:1992-A2:2013</u> - Degree of protection provided by enclosures. <u>BS EN ISO 13850:2015</u> - Safety of Machinery: Emergency Stops. <u>BS EN ISO 141211:2007</u> - Safety of Machinery: Principles for Risk Assessment. <u>BS EN 55011:2016+A1:2017</u> - Class A Group 2 Equipment - EMC Emissions. <u>BS EN ISO 61000-6-4:2007+A1:2011</u> - EMC Conducted Emissions. <u>BS EN ISO 61000-6-2:2005</u> - EMC Immunity. <u>Low Voltage Directive 2014/35/EC</u> - Including DIN EN 61557-1, -4 and -5. <u>Electro Magnetic Interference Directive 2014/30/EC</u> - Including DIN EN 61000-6 series of standards.</p>
<p>Manufacturer's Name:</p>	<p><u>A. Adkins & Sons Limited</u></p>
<p>Manufacturer's Address:</p>	<p>High Cross, 18 Lancaster Road, Hinckley, Leicester, LE10 0AW, United Kingdom.</p>
<p>Type of Equipment:</p>	<p>Studio Versa Heat Press</p>
<p>Standards Compliance:</p>	
<p>Model Number:</p>	<p>.....</p>
<p>Serial Number:</p>	<p>.....</p>
<p>Year of Manufacture:</p>	<p>.....</p>

I, the undersigned, hereby declare that the equipment specified above conforms to the above directives and standards.

Place: Hinckley, United Kingdom

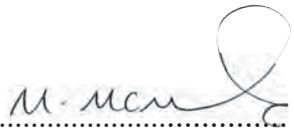
Signature: 

Date:

Full Name: Marie McMahon
 Position: General Manager