

**ADKINS**

# Studio Plate



## Operators Handbook

©2015 a.adkins and sons limited. all rights reserved

# Copyrights

---

© 2012 A. Adkins & Sons Limited, High Cross, Lancaster Road, Hinckley, Leicestershire.

Studio Plate Press is the registered trademark of A. Adkins & Sons Limited.

No part of this publication may be reproduced by any means without the prior written permission of A. Adkins & Sons Limited.

---

# Preface

---

Dear User

**Welcome to the growing group** of Adkins Studio Plate Press users. The product you have purchased has been carefully designed and manufactured to ensure that you, the user, will gain the maximum benefit.

**All Adkins products** are specifically designed to ensure ease of use with particular attention to safety requirements.

Should you discover any fault **or damage upon receipt of this product, you should immediately contact your supplier.**

---

# Contents

---

<b>1.</b>	<b>Introduction Studio Plate Press</b>	<b>1</b>
1.1	Specifications of the Studio Plate Press	2
1.2	Safety Tips	3
<b>2.</b>	<b>Installation</b>	<b>4</b>
2.1	Transport instructions	4
2.2	Installing the machine	4
2.3	Electrical requirements	4
2.4	Adjusting the pressure	5
<b>3.</b>	<b>How to operate the Studio Plate Press</b>	<b>6</b>
3.1	Starting with the Studio Plate Press	6
3.2	Working with heat transfer materials	6
3.3	Pressing pad assembly	7
3.4	Shutting down the machine	7
<b>4.</b>	<b>Maintenance of the Machine</b>	<b>8</b>
4.1	Daily maintenance	8
4.2	Periodic maintenance	8
4.3	Cleaning	8
<b>5.</b>	<b>Machine Drawings and Diagrams</b>	<b>9</b>
5.1	General Layout	10
5.2	Control Unit operation	11
5.3	Exploded Diagram and Parts List	12
<b>6.</b>	<b>Design Change</b>	<b>13</b>
<b>7.</b>	<b>Guarantee (Limited Warranty)</b>	<b>14</b>
	<b>Declaration of Conformity</b>	<b>15</b>

---

# 1. Introduction Studio Plate Press

---

**The Studio Plate press** is a budget priced press suitable for most low and medium pressure operations. This simple robust machine has digital controls for both heat and dwell accuracy and ease of operation but requires only minimal operating space.

**The work area of the Studio Plate press** is 11.5 cm and/or 15 cm diameter (4.5 in and/or 6 in diameter).

**The Studio Plate press** is produced in two versions, nominally 230 Volts AC for the 'European' market and nominally 110 Volts AC for the 'American' market.

## 1.1 Specifications of the Studio Plate Press

---

**The Studio Plate Press is a manually operated** heat press for transfer printing and material fusing. It is ideal for medium volume production.

**The work area of the Studio Plate Press** is 11.5 cm and/or 15 cm diameter (4.5 in and/or 6 in diameter).

<b><u>Specifications</u></b>	<b>European Machine</b>	<b>USA Machine</b>
Power consumption	250 Watts	250 Watts
Power supply	230 Volts AC	110 Volts AC
Max. working temperature	260°C	500°F
Display timer range	0 - 9999 sec	0 - 9999 sec
Machine height open	56 cm	22 in
Machine height closed	45 cm	18 in
Machine width	17 cm	6.5 in
Machine depth	27 cm	10.5 in
Net weight	11 kg	24 lbs
Press pad dimensions	11.5 cm and/or 15 cm diameter	4.5 ins and/or 6 in diameter
Fuses	3A	3A

## 1.2 Safety Tips

---

- ◆ **Our customer service department** has its own service engineers and, if required, maintenance is available.
  - ◆ **The Studio Plate Press** meets the European Legislation standard. Under normal conditions accidents are rare. However listed below are some practical points to ensure your safety.
    - **Always use both hands** when opening or closing the press for positive control of the movement of the handle.
    - **Always switch off** the current (and pull plug out of the socket) when undertaking maintenance work or when cleaning the machine.
    - **Ensure that there is** sufficient space around the machine. Cables and connections must not get jammed. Although the heat radiation of the press is low, there should be enough space for cooling down.
    - **Avoid contact** with the heat plate.
  - ◆ **DO NOT REMOVE THE INSTRUMENT COVER UNLESS QUALIFIED TO DO SO** - touching internal parts is dangerous and may cause shock hazard. All electrical connections inside covers are live. Never operate Press with any covers and/or guards removed.
  - ◆ **PROTECT THE MAINS CABLE** - damage to the mains cable may cause fire or shock hazard. When unplugging, hold by the plug only and remove carefully. Take care that the mains cable does not come into contact with the heat plate (or moving parts of the mechanism) during operation of the machine.
  - ◆ **OPERATING AMBIENT TEMPERATURE RANGE** - the operating ambient temperature range is 32°F - 104°F, (0°C - 35°C) and humidity of 20 - 80%.
  - ◆ **MACHINE FUSES** - type: ultra-rapid (FF) fuses 1¼" 240 Vac max. 3 Amps. (110 Vac max. 3 amps)
  - ◆ **WARNING - THIS APPARATUS MUST BE EARTHED (GROUNDED)**
  - ◆ **CAUTION**  
This machine gets hot whilst operating. Take care not to touch any surfaces that are labelled "Caution this plate is HOT".
  - ◆ **MACHINE OPERATION**  
Only persons trained to do so should operate this machine.
-

## 2. Installation

---

### 2.1 Transport instructions

---

**The machine comes to you** either shrink-wrapped or in a box. If you have to transport the machine at any time it is recommended that you use a similar box and packing method. Please let the machine cool down and lower the handle to the locked position.

### 2.2 Installing the machine

---

- 2.2.1 **Remove all** packaging from the heat press.
- 2.2.2 **Check to ensure** that no damage has been caused to the machine during transit.
- 2.2.3 **Place the machine** on a sturdy horizontal surface that is within easy reach of the operator and allow space for the handle to move up to the loading position. Ensure that no items vulnerable to heat radiation are too close to the machine.

### 2.3 Electrical requirements

---

**The Studio Plate Press** should be connected to the mains supply, (nominally 230V AC for the European Market or 110V AC for America) by the mains cable provided and a suitable plug.

**The press is** designed for 230 volts AC 50/60 hertz and require exclusive use of a power outlet rated for at least 10amps (Europe), **OR** for 110 volts AC  $\pm 5\%$ , 15 amps (America).

**Ensure that** the supply rating on the machine specification plate corresponds with your local supply and that the correct plug is fitted.

#### **MAINS LEAD**

**The wires** in this mains lead are coloured in accordance with the following code:

<b>Green and Yellow:</b>	<b>EARTH</b>
<b>Blue:</b>	<b>NEUTRAL</b>
<b>Brown:</b>	<b>LIVE</b>

**As the colours** of the wires in the mains lead of this apparatus may not

---



## Electrical requirements (cont.)

---

correspond with the coloured markings identifying the terminals in your plug, proceed as follows:-

1. **The wire coloured green and yellow** must be connected to the terminal in the plug that is marked by the letter E, or by the safety earth symbol coloured green, or green and yellow.
2. **The wire coloured blue** must be connected to the terminal, which is marked with the letter N, or coloured black.
3. **The wire coloured brown** must be connected to the terminal, which is marked with the letter L, or coloured red.

### **NOTE:**

**Replacement of the mains cable** must be done by a competent service engineer.

### **HEATING ELEMENT**

**The heating element** fitted to the **Studio Plate Press** is rated at 250 Watts.

**Never connect** to any outlet or power supply having a different voltage/frequency from that on the machine data plate.

## 2.4 Adjusting the pressure

---

**This press is fitted** with a pressure-adjusting table, which enables the table plate assembly to be raised or lowered.

- a) **To increase pressure** or to use thinner materials turn table anti-clockwise.
- b) **To decrease pressure** or to lower the table plate assembly to enable thicker materials to be used, turn the table clockwise.

### **NOTE**

**DO NOT** adjust the pressure when the machine is clamped shut

### **CAUTION**

**Never increase the pressure to the extent of requiring undue force, as this will place excessive stress on the press frame, resulting in permanent damage to the press. If, on raising the handle, the machine is lifted off the work surface then the clamping force is excessive!**

**Please refer to page 11 showing the operation of the control unit.**

---

## 3. How to Operate the Studio Plate Press

---

### 3.1 Starting with the Studio Plate Press

---

#### 3.1.1 Plug into your supply outlet and switch supply on.

**N.B.** Please ensure the mains plug is easily accessible to the operator so that in the event of a fault the machine can be unplugged.

#### 3.1.2 Turn on the Studio Plate Press; the on/off switch is on the left bottom side of the machine. Set the machine controls as necessary. See instructions for adjusting the pressure, **2.4** and the operation of the time/temperature unit, **Page 11**. When the set temperature is steady in the display the machine is ready to use.

**The head should be up** when warming to operating temperature.

### 3.2 Working with Heat Transfer Materials

---

**Always ascertain** from the supplier of material and transfer paper, that the material to be used is suitable for, and has been prepared for transfer printing.

#### 3.2.1 Ensure that the heat setting and dwell time setting are correct for the material being used.

#### 3.2.2 Adjust the pressure setting of the machine by rotating the table of the machine. (See exploded diagram in this manual) clockwise for less pressure and anti-clockwise for more pressure.

#### 3.2.3 Place the article to be transfer printed/fused etc., onto the pressing pad and locate the transfer paper/fusible material on top of the article in position required.

#### 3.2.4 Gently pull the toggle handle forward ensuring that the article is firmly clamped between the heat plate and pressure pad.

#### 3.2.5 When the pre-set dwell time has been reached, a buzzer will sound. The heat plate should then be lifted by pushing the handle back to its full extent.

---

## **Working with Heat Transfer Materials (cont.)**

---

**Unload the plate from the table of the machine, taking care not to touch the heating element, to avoid the risk of a burn.**

### **3.3 Pressing Pad Assembly**

---

**The pressing pad** normally supplied with this machine is silicone rubber. The pressing pad must be maintained in good condition at all times and replaced when showing signs of wear. A worn pressing pad will always affect the quality of printing/fusing. Do not insert items into the machine, which would tend to cut the pressing pad, i.e. buttons, pins, press-studs or zips.

**Never allow** the hot heat plate to rest on the pressing pad when the press is not being used as the pad may be damaged.

#### **IMPORTANT NOTE:**

**The pressing pad** supplied with the machine is of the correct thickness. Using a thicker pad may invalidate your warranty.

### **3.4 Shutting Down the Machine**

---

**To shut down the machine**, turn off the on/off switch at the bottom left side of the machine. The handle should be in the up position.

## 4. Maintenance of the Machine

---

### 4.1 Daily Maintenance

---

**For good press results** it is important to keep the press surfaces clean.

When heat plates are hot and not in use, keep in open position away from the silicone pad.

### 4.2 Periodic Maintenance

---

**Put a few drops of oil** onto the various pivot pins and the pressure adjusting screw every three months.

### 4.3 Cleaning

---

**First unplug the machine.** Clean the outside of the machine frequently with a clean, moist cloth. This may conveniently be carried out when the machine is cold.

## **5. Machine Drawings and Diagrams**

---

On the following pages are the schematic diagrams for the Studio Plate Press.

- 5.1 General Layout..... Page 10**
- 5.2 Operation of Control Unit..... Page 11**
- 5.2 Exploded Diagram and Parts List..... Page 12**

## 5.1 Machine General Layout

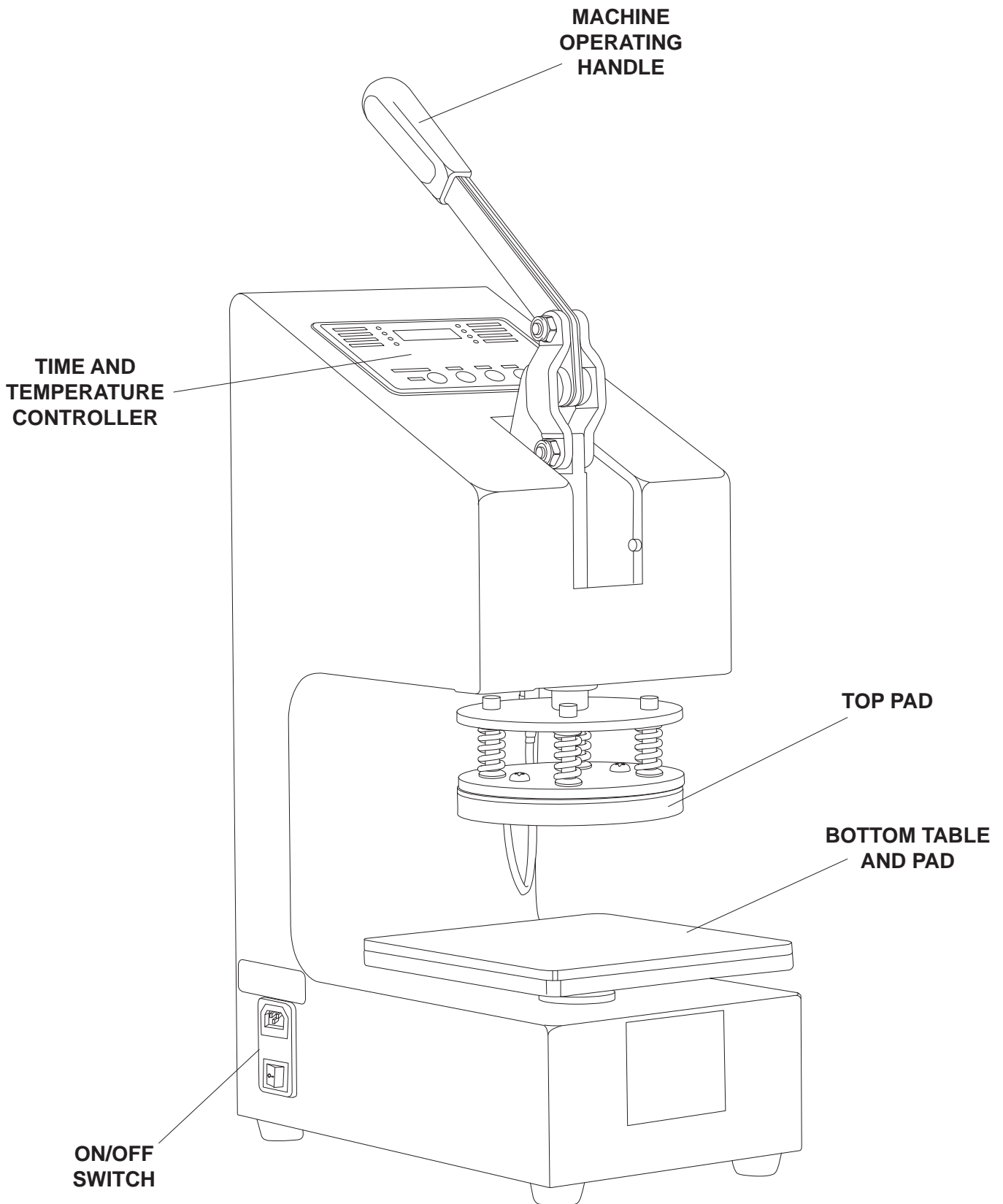

## 5.2 Operation Of Control Unit, Setting Temperature and Time

(The press must always be in the open position before the controller is set)

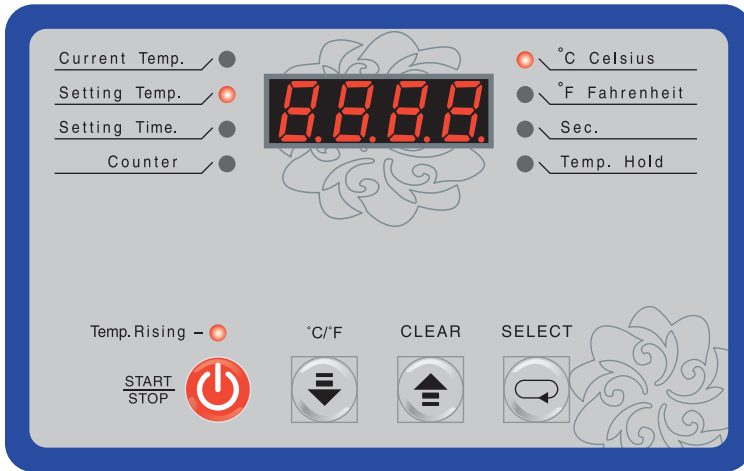

### Setting Temperature

1. Switch on machine.
2. Press 'SELECT' button to select 'Setting Temp' on LH indicator.
3. Use the 'up and down' arrow buttons to set the required temperature.
4. Press 'SELECT' button to select 'Current Temp' on LH indicator.
5. Press 'START/STOP' button to start the machine heating to the selected temperature.

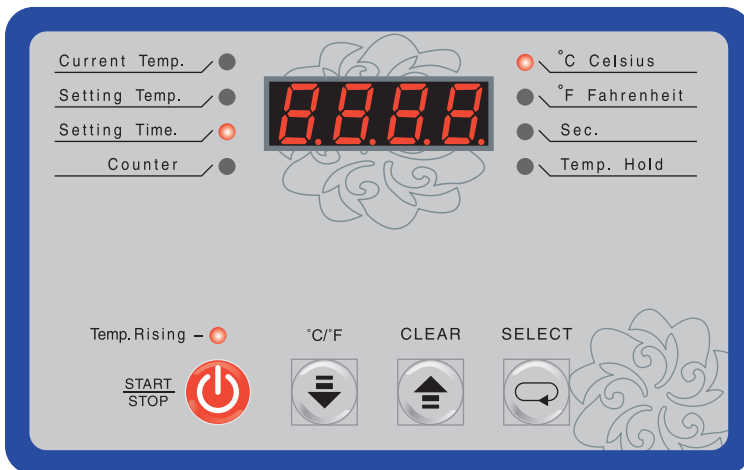

### Setting Time

1. Switch on machine.
2. Press 'SELECT' button twice to select 'Setting Time' on LH indicator.
3. Use the 'up and down' arrow buttons to set the required time.
4. Press 'SELECT' button to select 'Current Temp' on LH indicator.
5. Press 'START/STOP' button to start the machine.

### Selecting Temperature Format

1. Switch on machine.
2. Press and hold '°C/°F' button to select '°C Celsius' or '°F Fahrenheit' on RH indicator.
3. Press and hold '°C/°F' button again to toggle between the two temperature formats.

### Setting Digital Counter to Zero

1. Press 'SELECT' button three times to select 'Counter' on LH indicator.
2. Press and hold 'CLEAR' button to zero counter.

## 5.3 Exploded Diagram and Parts List

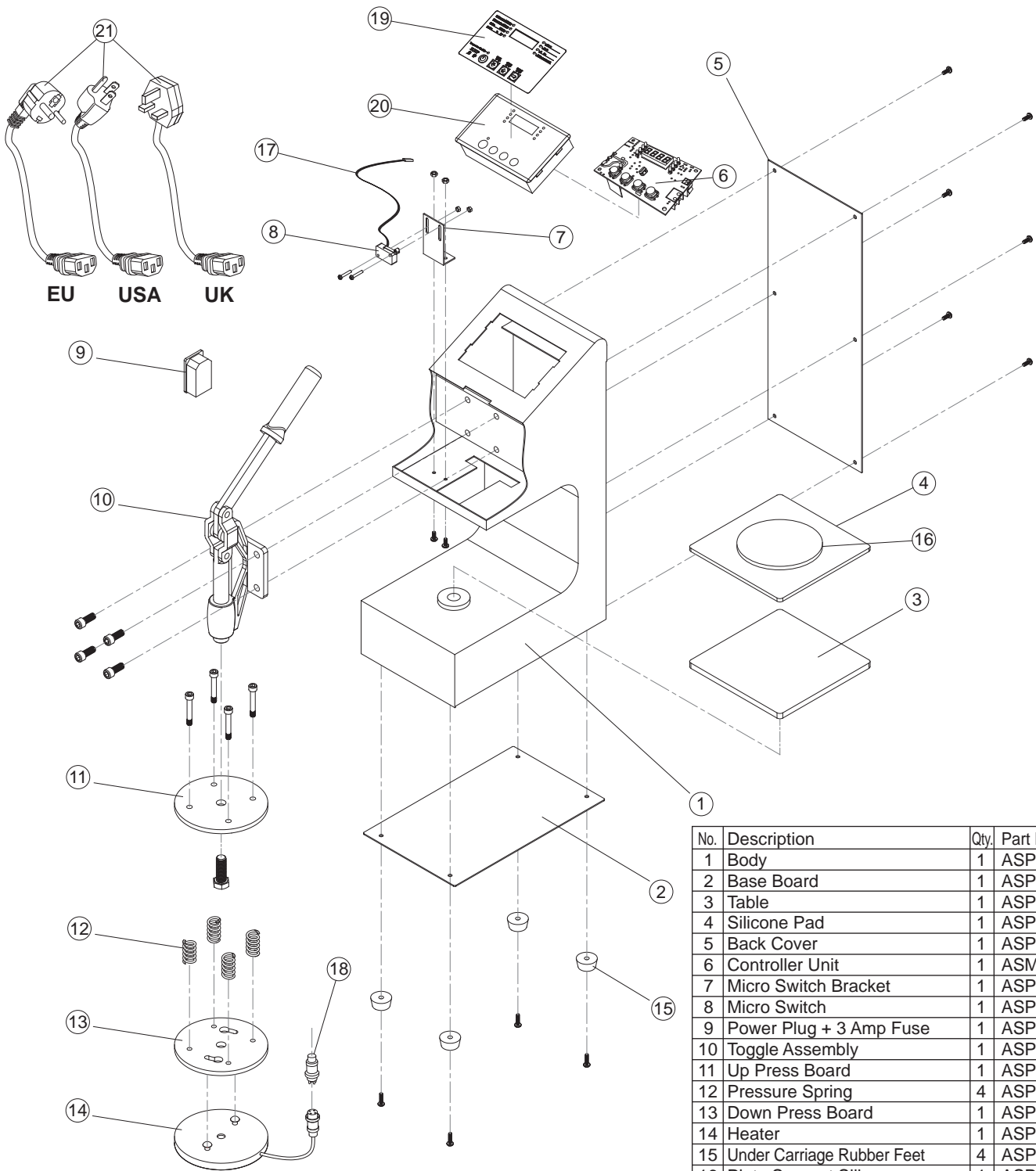

No.	Description	Qty.	Part No.
1	Body	1	ASP1
2	Base Board	1	ASP2
3	Table	1	ASP3
4	Silicone Pad	1	ASP4
5	Back Cover	1	ASP5
6	Controller Unit	1	ASM10/N
7	Micro Switch Bracket	1	ASP7
8	Micro Switch	1	ASP8
9	Power Plug + 3 Amp Fuse	1	ASP9
10	Toggle Assembly	1	ASP10
11	Up Press Board	1	ASP11
12	Pressure Spring	4	ASP12
13	Down Press Board	1	ASP13
14	Heater	1	ASP14
15	Under Carriage Rubber Feet	4	ASP15
16	Plate Support Silicone	1	ASP16
17	Micro Switch Cable With Plug	1	ASP17
18	Male Socket For Element	1	ASP18
19	PVC Facia	1	ASM18/N
20	Plastic Housing	1	ASM19
21	Mains Lead & Plug 230 V (UK)	1	BMC618
	Mains Lead & Plug 120 V (USA)	1	BMC618/A
	Mains Lead & Plug 230 V (EU)	1	BMC620



## 6. Design Change

---

**With the policy of constant improvement** and/or modification to meet changing conditions, the right is reserved to change the design and/or specifications at any time without prior notification, and therefore specifications may vary and not be in accordance with this manual.

## 7. Guarantee (Limited Warranty)

---

**A. Adkins & Sons Limited** warrants that the press is free from defects in material and workmanship for a period of 12 months from the date of supply to the customer. The machine comes with a one year warranty on parts and 90 days labour.

**This warranty covers** all parts to repair the defects, except when damage results from misuse or abuse, accident, alteration or negligence or when a machine has been improperly installed.

**If a press covered by warranty** should need to be returned to the factory for examination and repair, if on-site component replacement is not possible, A. Adkins & Sons Limited will make every effort to repair the customers press. The warranty will only be effective when A. Adkins & Sons Limited authorises the original purchaser to return the machine to the factory and only when the product upon examination has proven to be defective.

**Should in our opinion** any part of this press be defective in materials or workmanship, it will be replaced or repaired free of charge, provided that the press has been installed and operated in the correct manner and not subjected to misuse. If A. Adkins & Sons Limited authorise a replacement press, the warranty of the replacement press shall expire on the anniversary date of the original machines invoice to the customer.

**In order for this warranty to be effective**, no return of machine or parts may be made without prior factory authorisation. (This will exclude any travelling and/or carriage costs which will be charged at our discretion).

**This is the sole warranty given by the company**; there are no warranties, which extend beyond the description on the face hereof. The seller disclaims any implied warranty of merchantability and/or any implied warranty of fitness for a particular purpose; the buyer agrees that the goods are sold "as is". A. Adkins & Sons Limited does not warrant that the functions of the press will meet the customer's requirements or expectations. The entire risk as to use, quality and performance of the press lies with the customer. (No claim of any kind shall be greater than the sale price of the product or part to which the claim is made).

**In no event will A. Adkins & Sons Limited** be liable for any injury, loss or damage, including loss of profits, destruction of goods or any special, incidental, consequential or indirect damages arising from the use of the press or accompanying materials. This limitation will apply even if

A. Adkins & Sons Limited or its authorised agent had been advised of the possibility of such damage.

**A. ADKINS & SONS LIMITED**  
**DECLARATION OF CONFORMITY**



<p>Application of Council Directives:</p> <p>Standards to which Conformity is Declared:</p>	<p>Machinery, Low Voltage. E.M.C.</p> <p><b><u>BS EN ISO 12100-1:2003+A1:2009</u></b> - Safety of machinery: Basic Technology.  <b><u>BS EN ISO 12100-2:2003</u></b> - Safety of machinery: Principles of Design.  <b><u>BS EN 60204-1:2006</u></b> - Safety of machinery: Electrical Equipment of Machines.  <b><u>BS EN 60529:1992</u></b> - Degrees of protection provided by enclosures.  <b><u>BS EN ISO 13850:2008</u></b> - Safety of machinery: Emergency Stops.  <b><u>BS EN ISO 141211:2007</u></b> - Safety of machinery: Principles for Risk Assessment.  <b><u>BS EN 55011:1998</u></b> - Class A Group 2 equipment - EMC Emissions.  <b><u>BS EN ISO 61000-6-4:2007</u></b> - EMC Conducted Emissions.  <b><u>BS EN ISO 61000-6-2:2005</u></b> - EMC Immunity.</p>
<p>Manufacturer's Name:</p>	<p><b><u>A. Adkins &amp; Sons Limited</u></b></p>
<p>Manufacturer's Address:</p>	<p>High Cross, 18 Lancaster Road,          Hinckley, Leicester, LE10 0AW, United Kingdom.</p>
<p>Type of Equipment:</p>	<p>Studio Plate Heat Press</p>
<p>Model Number:</p>	<p>.....</p>
<p>Serial Number:</p>	<p>.....</p>
<p>Year of Manufacture:</p>	<p>.....</p>

I, the undersigned, hereby declare that the equipment specified above conforms to the above directives and standards.

Place: Hinckley, United Kingdom

Signature: 

Date: .....

Full Name: Marie McMahon  
 Position: General Manager