

The Future of Heat press technology...

ADKINS

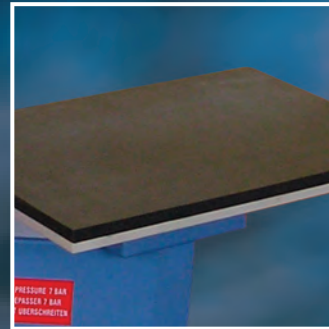

Omega
Series 500
Heat press

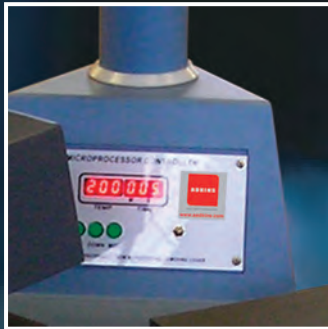
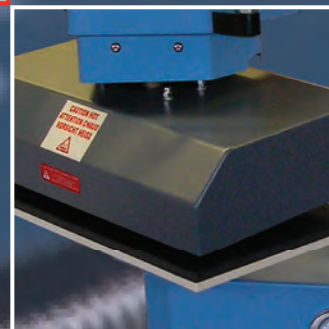
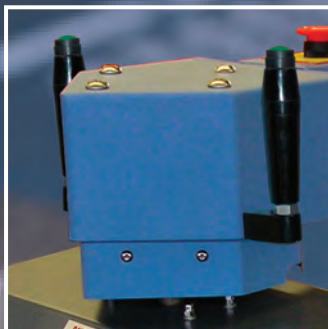

operators handbook



HEAT PRESS TECHNOLOGY

Copyrights

©2013, **A. Adkins & Sons Limited**, High Cross, Lancaster Road, Hinckley, Leicestershire. No part of this publication may be reproduced by any means without the prior written permission of A. Adkins & Sons Limited.

Omega Series 500 Press is a registered trademark of A. Adkins & Sons Limited.

Please read this manual carefully and keep it with your machine at all times for reference.

Preface

Dear User

Welcome to the growing group of Omega Series 500 Press users. The product you have purchased has been carefully designed and manufactured to ensure that you, the user, will gain the maximum benefit.

All A. Adkins & Sons products are specifically designed to ensure ease of use with particular attention to safety requirements.

Should you discover any fault or damage upon receipt of this product, you should immediately contact your supplier.

Contents

1.	Introduction Omega Series 500 Press	1
1.1	What did you receive?	2
1.2	Specifications of the Omega Series 500 Press	3
1.3	Safety	4
1.4	Safety tips	4
2.	Installation	6
2.1	Transport instructions	6
2.2	Installing the machine	6
2.3	Electrical requirements	6
2.4	Pneumatic requirements	7
2.5	Adjusting the pressure	7
3.	How to operate the Omega Series 500 Press	8
3.1	Starting with the Omega Series 500 Press	8
3.2	Working with heat transfer materials	8
3.3	Pressing pad assembly	9
3.4	Shutting down the machine	9
3.5	Fault diagnosis	9
3.6	Hints and tips	10
4.	Maintenance of the Machine	11
4.1	Daily maintenance	11
4.2	Periodic maintenance	11
4.3	Cleaning	11
5.	Machine Drawings and Diagrams	12
5.1	General layout	13
5.2	Control unit operation	14
5.3	Exploded diagram and parts list	15
5.4	Machine - electrical diagram	16
5.5	Controller - electrical diagram	17
5.6	Pneumatic schematic	18
6.	Design Change	19
7.	Guarantee	20
	Declaration of Conformity	21

1. Introduction Omega Series 500 Press

The Omega Series 500 Press is a pneumatically operated heat press for transfer printing and material fusing. It is ideal for medium volume production with low operator fatigue.

The work areas of the Omega Series 500 Press are 21 x 34 cm (8.25 x 13.3 in) but machines may have special order, optional smaller sized interchangeable worktables of any size and various shapes within these table sizes.

The Omega Series 500 Press has a heat plate which swings away from the operating position to clear the worktable for loading and unloading. After loading the work piece, and with the correct settings for temperature, pressure and dwell time, the heat plate is swung to the operating position with the handles provided. The cycle is started by simultaneously pressing the two green buttons on the top of the handles within ½ second. The controller operates the timer and the solenoid valve and thus the pneumatic cylinder. When the set time elapses the Heat Plate is automatically lifted, enabling the head to be swung away. The worktable may then be unloaded and reloaded ready for another cycle.

The Omega Series 500 Press is produced in two versions, nominally 230-240 Volts AC for the European market and nominally 110 Volts for the American market.

It is a simple operation to remove the worktable and replace it with one of a different size.

1.1 What did you receive?

The Omega Series 500 Press has been placed in a crate, and then held in place with a wooden jig and protected by a polystyrene liner finally it is banded onto a pallet, for safe transportation. The following articles should have been delivered:

- Omega Series 500 Press complete with mains cable and plug
- Omega Series 500 Press Operators Handbook
- Any extra items ordered

If there is any damage or any article is missing, please contact your supplier immediately.

1.2 Specifications of the Omega Series 500 Press

The Omega Series 500 Press is a pneumatically operated heat press for transfer printing and material fusing. It is ideal for medium volume production with low operator fatigue.

The work area of the Omega Series 500 Press is 21 x 34 cm (8.25 x 13.3 in) but machines may have, to special order, optional smaller sized interchangeable worktables of any size and various shapes within this table size.

<u>Specification</u>	<u>European Machine</u>
Power consumption	1500 Watts
Power supply	230 Volts AC
Compressed air supply	7 bar max
Working temperature	70-235°C
Display Timer Range	0 – 9.59 min
Machine height open	49 cm
Machine width	85 cm
Machine depth	61 cm
Weight export packed	71 kg
Size export packed	94(L) x 65(W) x 65 cm (H)
Net weight	45 Kg
Press pad dimensions (x2)	21 x 24 cm
Fuses	8A

<u>Specification</u>	<u>USA Machine</u>
Power consumption	1600 Watts
Power supply	110 Volts AC
Compressed air supply	100 psi max
Working temperature	160-455°F
Display Timer Range	0 – 9.59 min
Machine height open	19.3 in
Machine width	33.5 in
Machine depth	24 in
Weight export packed	156.5 lbs.
Size export packed	37(L) x 25.5(W) x 25.5 in (H)
Net weight	99.2 lbs.
Press pad dimensions (x2)	8.25 x 13.3 in
Fuses	16A

1.3 Safety

The Omega Series 500 Press has been equipped with various safety features to ensure operator safety.

- a. **A thermal cut-out** on the heating element shuts off the power to the element if the temperature exceeds $235^{\circ}\text{C} \pm 15^{\circ}\text{C}$ ($455^{\circ}\text{F} \pm 27^{\circ}\text{F}$).
- b. **The time/temperature** controller has a built in facility giving error messages in the event of faults with the element heating and control system.
- c. **A two button** starting system ensures that the operator's hands are well away from the heat plate when the table rises.
- d. **Emergency stop button.**
- e. **The machine table** will only set to pressing position when the heat plate is aligned with it due to a micro switch safety interlock

1.4 Safety Tips

If required, our customer service team can arrange maintenance service.

- ◆ **The Omega Series 500 Press** meets the European Legislation standard. Under normal conditions accidents are rare. However listed below are some practical points to ensure your safety.
 - **Always switch off** and isolate the mains supply (i.e. Remove plug) before undertaking any maintenance work or cleaning the machine.
 - **Keep other people** away from the machine during use.
 - **Ensure that there is** sufficient space around the machine. Cables and connections must not get jammed. Although the heat radiation of the press is low, there should be enough space for cooling down.
 - **Avoid contact** with the press element.
 - ◆ **DO NOT REMOVE THE TOP COVER UNLESS QUALIFIED TO DO SO** - touching internal parts is dangerous and may cause shock hazard.
 - ◆ **PROTECT THE MAINS CABLE** - damage to the mains cable may cause fire or shock hazard. When unplugging, hold by the plug only and remove carefully. Take care that the mains cable does not come into contact with the heat plate (or
-

Safety Tips (cont.)

moving parts of the mechanism) during operation of the machine.

- ◆ **OPERATING AMBIENT TEMPERATURE RANGE** - the operating ambient temperature range is 32°F - 104°F, (0°C - 35°C) and humidity of 20 - 80%. This heat press is fitted with a thermal cut out to ensure that it cannot operate above 235°C ± 15°C (455°F ± 27°F).

- ◆ **MACHINE FUSES** - type: 2-8 amp x 20 mm long fuse incorporated into mains socket unit.

- ◆ **WARNING - THIS APPARATUS MUST BE EARTHED (GROUNDED)**

- ◆ **CAUTION**

This machine gets hot whilst operating. Take care not to touch any surfaces that are labelled "Caution this plate is HOT".

- ◆ **MACHINE OPERATION**

Only suitably trained personnel should operate this machine.

This machine is designed to be operated by one operator only.

If air pressure is lost the machine will operate normally until the air reservoir is empty.

Contact your print media suppliers to ascertain whether fumes are given off during the process, and if so what precautions are needed for operator safety. These may include air extraction and/or masks for personnel.

Please refer to page 13 for an illustration of the Omega Series 500 Press.

2 Installation

2.1 Transport instructions

The machine comes to you a crate, and then held in place with a wooden jig and protected by a polystyrene liner finally it is banded onto a pallet. If you have to transport the machine at any time it is recommended that you use a similar box and packing methods. Please let the machine cool down, and remove the swing head handles.

2.2 Installing the machine

Take the machine out of the box, due to the weight of the machine we recommend that this be a 2-person task. Put the machine on a sturdy worktable close to a suitable electric socket and compressed air supply connection point within easy reach of the operator. There must be sufficient space for the machine's head to swing to the right and left until it hits the built in stop and back to the pressing position without creating trapping points against adjacent articles. Ensure that no items vulnerable to heat radiation are too close to the machine.

2.3 Electrical requirements

The Omega Series 500 Press should be connected to the mains supply (nominally 230 V AC for the European Market) a moulded plug is fitted to the cable provided.

The press is designed for 230 volts AC 50/60 hertz and requires exclusive use of a power outlet rated for at least 13 amps (Europe).

Ensure that the supply rating on the machine specification plate corresponds with your local supply and that the correct plug is fitted.

MAINS LEAD

The wires in this mains lead are coloured in accordance with the following code:

230 VAC	⎧	Green and Yellow:	EARTH	(GREEN)	⎥	120VAC
		Blue:	NEUTRAL	(WHITE)		
		Brown:	LIVE	(BLACK)		

2.3A Wiring the plug For a 230 VAC machine

As the colours of the wires in the mains lead of this apparatus may not correspond with the coloured markings identifying the terminals in your plug, proceed as follows:-

1. **The wire**, which is, coloured green and yellow must be connected to the terminal in the plug, which is marked by the letter E, or by the safety earth symbol coloured green, or green and yellow.
2. **The wire** coloured blue must be connected to the terminal, which is marked with the letter N, (Neutral connector).
3. **The wire** coloured brown must be connected to the terminal, which is marked with the letter L, (Live connector).

NOTE:

Replacement of the mains cable must be done by a competent service engineer.

2.4 Pneumatic requirements

The Omega Series 500 Press should be connected through a filter regulator to a compressed air supply capable of delivering 60 litres/min at a pressure of 3.5 - 7 bar max. (2 cu.ft/min at 50-100 psi). The press will not operate if the pressure drops below 3.5 bar. (40 psi.) Double hose clips should be used on the delivery hose.

We would advise that when setting up the machine you check that sufficient pressure is maintained into the rear regulator valve. When the desired pressure is achieved the regulator is locked by pushing the knob back down. We recommend that this should be set between 4 to 6 Bar. The Pressure Adjustment Gauge on the front of the machine should only be used to control the settings required for heat transfer and garments.

2.5 Adjusting the pressure

This press is fitted with a manually adjustable pneumatic pressure regulator on the base of the machine. To adjust the operating air pressure, and therefore the pressure exerted by the press on the work, the regulator is unlocked by pulling forward the black plastic knob. Turning the regulator knob clockwise will increase the air pressure; turning anticlockwise will decrease the pressure. When the desired pressure is achieved the regulator is locked by pushing the knob back in.

3. How to Operate the Omega Series 500 Press

3.1 Starting with the Omega Series 500 Press

3.1.1 Turn on the Omega Series 500 Press; the on/off switch is on the Right Hand side of the Base Unit. Set the machine controls as necessary. See instructions for adjusting the pressure, **2.5**, and the operation of the time temperature unit, **page 14**. When the set temperature is steady in the display the machine is ready to use.

3.2 Working with Heat Transfer Materials

3.2.1 Ascertain from the supplier of the transfer paper and/or the suppliers of the material, that the material to be used is suitable and has been prepared for transfer printing.

3.2.2 Obtain from the supplier of the transfer paper, or material to be used, the recommended temperature, time and pressure settings for the material to be worked on.

Approximate settings are usually within the following:-

180°C - 200°C (350°F - 400°F)	Heat Setting
10 - 30 seconds	Time Dwell Setting

3.2.3 Wait until the set temperature has been reached, signalled by the temperature on the controller display becoming steady at the desired figure. Swing the heat plate assembly to the right, or left using the handles on the both sides of the machine. Place the work piece on the pressure pad, removing all wrinkles. Place the transfer in the desired position. Swing the heat plate into the pressing position, to the stop, to 'make' the micro switch will enable the machine to cycle.

3.2.4 Start the sequence by pressing the two green buttons simultaneously (within 0.5 seconds). The heat plate automatically drops to the table. (The process can be stopped at any time by using the "MODE" button on the front of the Controller. This will automatically lift the heat plate).

3.2.5 At the end of the set time, the heat plate lifts to the loading position, allowing the head to be swung aside to permit unloading.

3.3 Pressing Pad Assembly

The pressing pads supplied with this machine are silicone rubber. The pressing pads must be maintained in good condition at all times and replaced when showing signs of wear. A worn pressing pad will always affect the quality of printing/fusing. Do not insert items into the machine, which would tend to cut the pressing pad, i.e. buttons, pins, press-studs or zips.

IMPORTANT NOTE:

The pressing pad supplied with the machine is of the correct thickness. Using a thicker pad may invalidate your warranty.

3.4 Shutting Down

To shut down the machine when a cycle is finished, turn off the green illuminated rocker switch on the right hand side of the Machine Base.

To temporarily interrupt the cycle, press the mode release button once.

To shut down in an emergency, press the red button on the top of the machine head. If the emergency stop button is actuated, it will need to be unlocked by turning it clockwise before the machine will run again.

3.5 Fault Diagnosis

This Omega Series 500 Press has built in fault diagnosis. The display may show the following:

1. Heat Fault

If the element of the heat press, or the thermal cut-out go open circuit, after approximately 20 minutes the display will show “Heat Fault”. If this display is seen, contact your machine supplier immediately.

2. Probe Fault

If the probe goes open circuit, the display will show “Probe Fault” immediately. Contact your machine supplier immediately.

3. “CAL” Fault

If “CAL” appears in the controller display the controller will need to be recalibrated. Switch off the machine and contact your supplier for an instruction sheet.

Fault Diagnosis (cont.)

CAUTION

In all fault conditions switch off the power to the machine and unplug the machine from the electrical supply before contacting your machine supplier.

3.6 Hints and Tips

Transfer Printing

Extra care should always be taken to ensure that transfer paper is placed print down onto the article, as mistakes will result in the heat plate becoming soiled with ink and spoiling following work.

When transfer printing, it may be found advantageous to cover the press pad with paper or P.T.F.E. to prevent strike-through of surplus ink, particularly when printing thin material as surplus print on the pressing pad cover can also strike back on the following work.

Transfer Paper/Motifs Fail to Print Out Correctly

Check:-

1. **Heat and time** dwell settings are correct.
2. **Article** having transfer applied is locked in contact between pressing pad and heat plate.
3. **Pressing pad** is in good condition, is flat and making complete contact over the whole area of the heat plate. See Pressing Pad details.

“Ghosting” (Double Image) of Transfer Prints

Check:-

1. **Material being used** has been correctly heat set for transfer printing.
 2. **Material being used** does not shrink during printing process, i.e. measure material before and after printing.
 3. **Transfer paper** does not move after printing process upon lift off of the heat plate.
 4. **If possible**, use adhesive coated paper, particularly to overcome fabric shrinkage.
 5. **By pre-shrinking** of material in press before transfer printing.
-

4. Maintenance of the Machine

4.1 Daily Maintenance

For good press results it is important to keep the press surfaces clean. Wipe the surface of the heat plate with a dry non-abrasive cloth before use when the plate is cold.

When heat plates are hot and not in use, keep in the open position away from the silicone pad.

4.2 Periodic Maintenance

Periodically clean the Teflon coated heat platen with a non-abrasive piece of cloth. Stubborn stains may be cleaned, *when platen is cool*, with mineral spirits.

4.3 Cleaning

First unplug the machine. Clean the outside of the machine frequently with a clean, moist cloth. This may conveniently be carried out when the machine is cold.

To prevent soiling of substrate, periodic wiping of entire exterior machine, including platens, with a clean rag is recommended. If necessary, use mineral spirits for cleaning a *cold* machine. Since mineral spirits are flammable, use precautions at all times and keep away from sparks, flames or hot heat platen.

5. Machine Drawings and Diagrams

On the following pages are the schematic diagrams for the Omega Series 500 Press.

5.1	General Layout.....	Page 13
5.2	Control Unit – Operation.....	Page 14
5.3	Exploded Diagram and Parts List.....	Page 15
5.4	Machine - Electrical Diagram.....	Page 16
5.5	Controller - Electrical Diagram.....	Page 17
5.6	Pneumatic Schematic.....	Page 18

5.1 General Layout

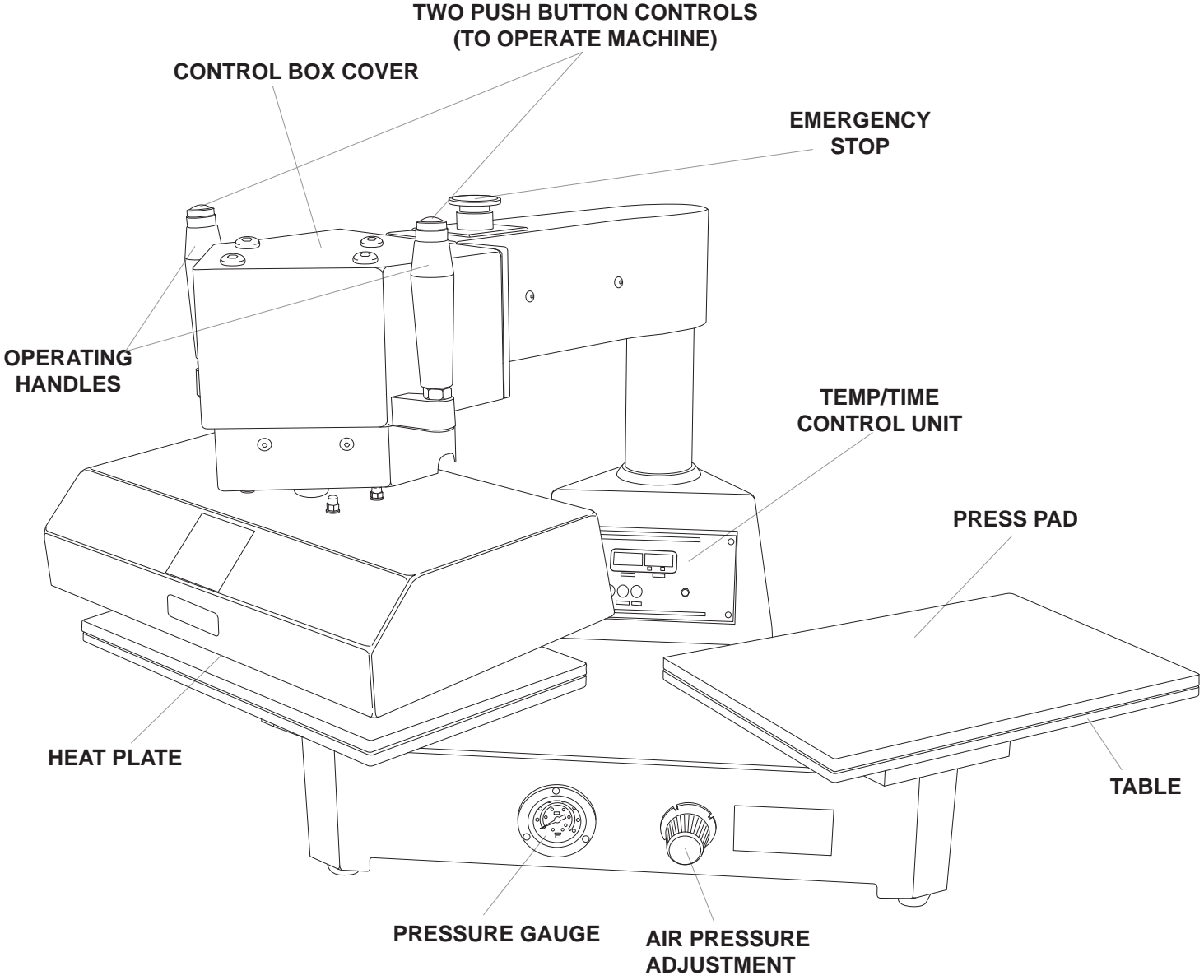

5.2 Operation Of Control Unit, Setting Time and Temperature

(The Heat Plate must always be in the down position before the Controller is set)

1

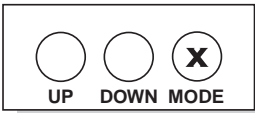

To set the time:
press the "MODE" button once

2

TEMP	TIME	
	0	20
	M.	SEC.

The display will now show

3

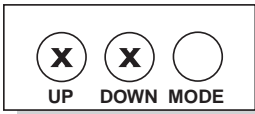

Use the "UP" & "DOWN" buttons
to set the desired time
within the range 0 to 9 mins 59 secs

4

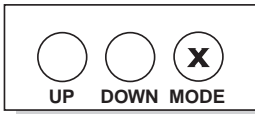

Now press the "MODE" button, this will save
the set time and put the controller into the
set temperature mode

5

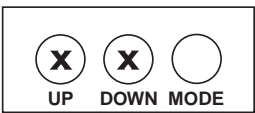

Use the "UP" & "DOWN" buttons
to set the desired temperature
within the range 70 - 235°C
(158°F - 455°F)

6

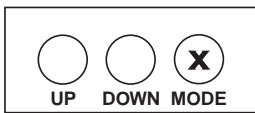

Press the "MODE" button once, this will save
the temperature and return the controller into
its normal operating condition

5.3 Exploded Diagram and Parts List

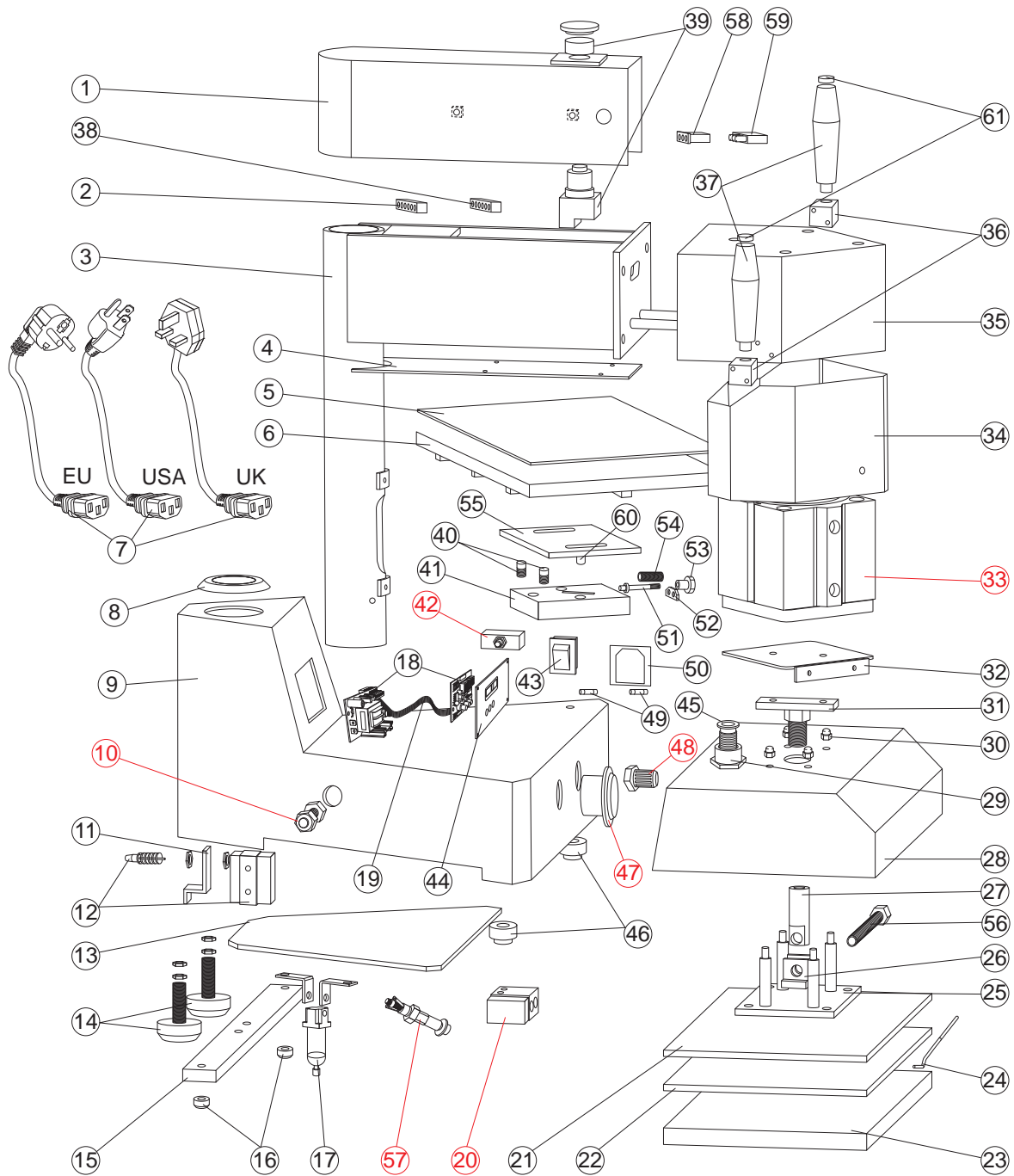

ITEM	DESCRIPTION	QTY.	PART No.
1	SWING ARM COVER	1	TMC016
2	6 WAY SOCKET	1	TMC060
3	SWING ARM	1	TMC008
4	SWING ARM BOTTOM COVER	1	TMC017
5	SILICON PAD	2	TMC036
6	TABLE	2	TMC004
7	MAINS LEAD & PLUG (UK)	1	BMC618
	MAINS LEAD & PLUG (USA)	1	BMC618/A
	MAINS LEAD & PLUG (EU)	1	BMC620
8	SWING ARM COLLAR	1	TMC044
9	FRAME	1	TMC030
10	STRAIGHT CONNECTOR	1	TMC062
11	MICROSWITCH BRACKET	1	TMC020
12	MICROSWITCH	1	OMC042
13	ELECTRICAL COMPONENT PLATE	1	TMC029
14	REAR FOOT	2	OMC034
15	REAR STABILISER	1	TMC032
16	RUBBER FEET	4	SWC33
17	FILTER UNIT	1	TMC033
18	CONTROLLER	1	BMC322/500
19	WIRING LOOM	1	TMC041
20	3 WAY SOLENOID VALVE	1	TMC063
21	CLAMP PLATE	1	TMC002

22	ELEMENT (230V 1500W)	1	TMC003
23	HEAT PLATE	1	TMC001
24	PROBE (1.5 m)	1	FPC3057/L
25	HEAT PLATE ADAPTOR	1	TMC010
26	YOKE	1	TMC013
27	THRUST BAR	1	TMC011
28	INSULATION COVER	1	TMC031
29	GLAND	1	BCC40
30	DOME NUTS	4	NSI
31	CYLINDER ADAPTOR	1	TMC009
32	CYLINDER COVER FIXING PLATE	1	TMC026
33	CYLINDER ASSEMBLY	1	TMC064
34	CYLINDER COVER	1	TMC025
35	HEAD	1	TMC027
36	HANDLE MOUNTING BLOCKS	2	TMC045
37	HANDLES	2	TMC046
38	6 WAY PLUG	1	BMPC61
39	EMERGENCY STOP BUTTON ASSEMBLY	1	AMC340
40	TABLE PINS	4	TMC005
41	TABLE MOUNTS	2	TMC006
42	FLOW REGULATOR	1	TMC065
43	ROCKER SWITCH	1	BMC448
44	FACIA	1	NCC85
45	INSULATOR	1	BMC247

46	FRONT FOOT SPACERS	2	TMC023
47	PRESSURE GAUGE	1	TMC066
48	REGULATOR	1	OMC047
49	FUSES (8 AMP x 20 mm)	2	BMC476
50	SOCKET/FUSE	1	BMPC23
51	PLUNGERS	2	CPC07
52	PLUNGER RETAINING PLATES	2	CPC10
53	KNOBS	2	CPC08
54	SPRING	2	CPC09
55	TABLE SLIDING PLATES	2	TMC015
56	YOKE PIN	1	TMC069
57	PRESSURE SWITCH	1	TMC070
58	3 WAY SOCKET	1	TMC067
59	3 WAY PLUG	1	TMC068
60	LARGE TABLE PINS	2	TMC005/L
61	POWER BUTTONS	2	TMC070

5.4 Electrical Diagram

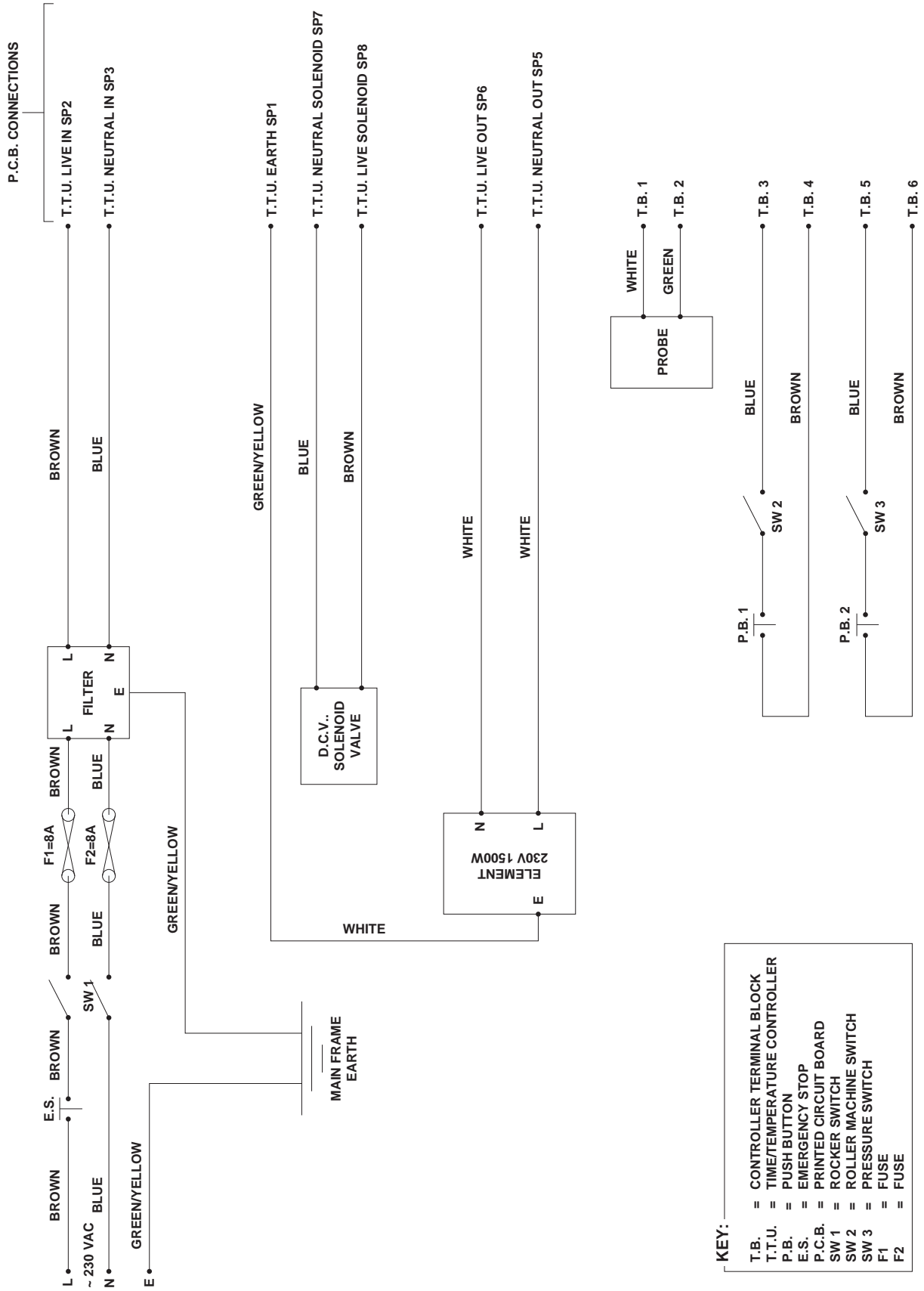

- KEY:**
- T.B. = CONTROLLER TERMINAL BLOCK
 - T.T.U. = TIME/TEMPERATURE CONTROLLER
 - P.B. = PUSH BUTTON
 - E.S. = EMERGENCY STOP
 - P.C.B. = PRINTED CIRCUIT BOARD
 - SW 1 = ROCKER SWITCH
 - SW 2 = ROLLER MACHINE SWITCH
 - SW 3 = PRESSURE SWITCH
 - F1 = FUSE
 - F2 = FUSE

5.5 Controller Wiring Diagram

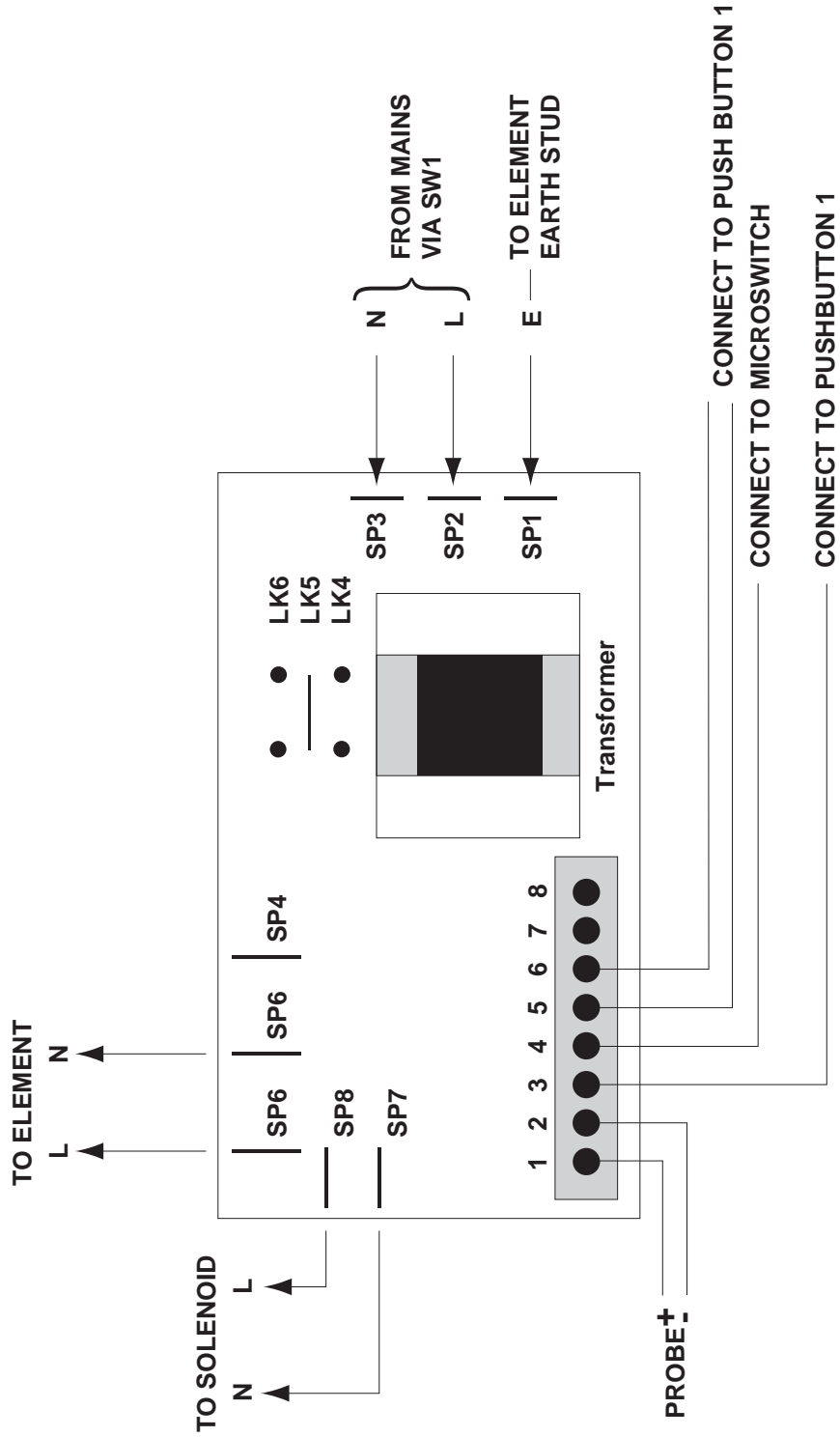

5.6 Pneumatic Schematic

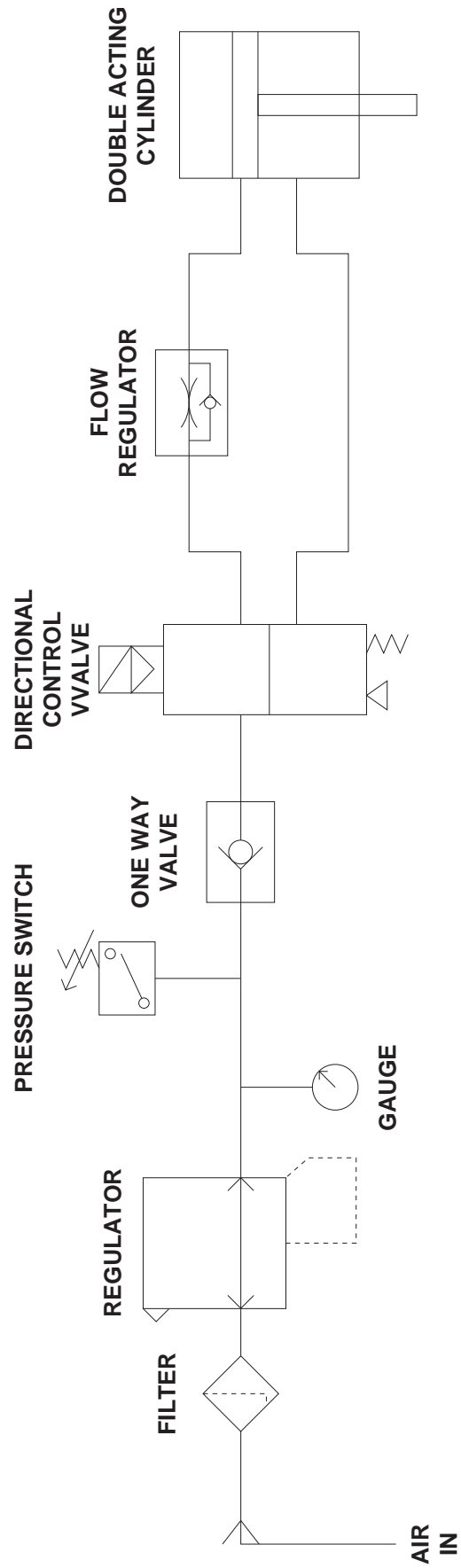

6. Design Change

With the policy of constant improvement and/or modification to meet changing conditions, the right is reserved to change the design and/or specifications at any time without prior notification, and therefore specifications may vary and not be in accordance with this manual.

7. Guarantee (Limited Warranty)

A. Adkins & Sons Limited warrants that the press is free from defects in material and workmanship for a period of 12 months from the date of supply. The machine comes with a lifetime warranty on the heating element, one year warranty on parts and 90 days labour.

This guarantee will only be effective when A. Adkins & Sons Limited authorises the original purchaser to return the machine to the factory, and only when the product upon examination has proven to be defective.

Should in our opinion any part of this press be defective in materials or workmanship, it will be replaced or repaired free of charge, provided that the press has been installed and operated in the correct manner and not subjected to misuse. (This is excluding any travelling and/or carriage costs which will be charged at our discretion.)

This guarantee does not apply to any machine that has been subjected to misuse, negligence, alteration or accident.

A charge will be made for any costs incurred if a reported fault on the press is found to be due to incorrect installation, operation and/or incorrect materials being used. It is the responsibility of the press user to ensure the suitability of the materials operating through the press.

In order for this guarantee to be effective, no return of machine or parts may be made without prior factory authorisation.

No claim of any kind shall be greater in amount than the sale price of the product or part to which the claim is made.

This is the sole guarantee given by the company, it is in lieu of any other guarantees, expressed or implied, in law or in fact, including the guarantees of merchantability and fitness for particular use, and is accepted as such by the purchaser in taking delivery of this product.

A. Adkins & Sons Limited shall not be liable for any injury, loss or damage, direct or consequential, arising out of the use or the inability to use the product.

A. ADKINS & SONS LIMITED
DECLARATION OF CONFORMITY



<p>Application of Council Directives:</p> <p>Standards to which Conformity is Declared:</p>	<p>Machinery, Low Voltage. E.M.C.</p> <p><u>BS EN ISO 12100-1:2003+A1:2009</u> - Safety of machinery: Basic Technology. <u>BS EN ISO 12100-2:2003</u> - Safety of machinery: Principles of Design. <u>BS EN 60204-1:2006</u> - Safety of machinery: Electrical Equipment of Machines. <u>BS EN 60529:1992</u> - Degrees of protection provided by enclosures. <u>BS EN ISO 13850:2008</u> - Safety of machinery: Emergency Stops. <u>BS EN ISO 141211:2007</u> - Safety of machinery: Principles for Risk Assessment. <u>BS EN 55011:1998</u> - Class A Group 2 equipment - EMC Emissions. <u>BS EN ISO 61000-6-4:2007</u> - EMC Conducted Emissions. <u>BS EN ISO 61000-6-2:2005</u> - EMC Immunity.</p>
<p>Manufacturer's Name:</p>	<p><u>A. Adkins & Sons Limited</u></p>
<p>Manufacturer's Address:</p>	<p>High Cross, 18 Lancaster Road, Hinckley, Leicester, LE10 0AW, United Kingdom.</p>
<p>Type of Equipment:</p>	<p>Omega Series 500 Heat Press</p>
<p>Model Number:</p>	<p>.....</p>
<p>Serial Number:</p>	<p>.....</p>
<p>Year of Manufacture:</p>	<p>.....</p>

I, the undersigned, hereby declare that the equipment specified above conforms to the above directives and standards.

Place: Hinckley, United Kingdom

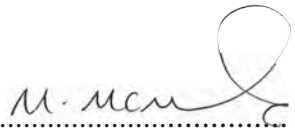
Signature: 

Date:

Full Name: Marie McMahon
 Position: General Manager