

ADKINS

Beta Major

Rev A - 24/08/18



Operators Handbook

©2018 a.adkins and sons limited. all rights reserved

Copyrights

©2018, A. Adkins & Sons Limited,
High Cross,
18 Lancaster Road,
Hinckley,
Leicestershire
LE10 0AW

No part of this publication may be reproduced by any means without the prior written permission of A. Adkins & Sons Limited.

Beta Major is a registered trademark of A. Adkins & Sons Limited.

Please read this manual carefully and keep it with your machine at all times for reference.

Preface

Dear User

Welcome to the growing group of Beta Major Users. The product you have purchased has been carefully designed and manufactured to ensure that you, the user, will gain the maximum benefit.

All Adkins products are specifically designed to ensure ease of use with particular attention to safety requirements.

Should you discover any fault or damage upon receipt of this product, you should immediately contact your supplier.

Contents

1.	Introduction Beta Major	1
1.1	What did you receive?	2
1.2	Specifications of the Beta Major	3
1.3	Safety	4
1.4	Safety tips	4
2.	Installation	6
2.1	Transport instructions	6
2.2	Installing the machine	6
2.3	Electrical requirements	6
2.4	Pneumatic requirements	7
2.5	Adjusting the pressure	7
3.	How to operate the Beta Major	8
3.1	Starting with the Beta Major	8
3.2	Working with heat transfer materials	8
3.3	Material fusing	9
3.4	Pressing pad assembly	9
3.5	Shutting down the machine	9
3.6	Fault diagnosis	10
3.7	Hints and tips	10
4.	Maintenance of the Machine	12
4.1	Daily maintenance	12
4.2	Periodic maintenance	12
4.3	Cleaning	12
5.	Machine Drawings, Diagrams and Declaration	13
5.1	General layout	14
5.2	Control unit operation	15
5.3	Exploded diagram and parts list	16
5.4	Machine electrical schematic	17
5.5	Controller wiring diagram	18
5.6	Pneumatic schematic	19
6.	Design Change	20
7.	Guarantee	21
	Declaration of Conformity	22

1. Introduction Beta Major

The Beta Major is a pneumatically operated heat press for transfer printing and material fusing. It is ideal for high volume production with low operator fatigue.

The work area of the Beta Major is 38 x 50 cm (15 x 20 in), but machines may have to special order, optional smaller sized interchangeable worktables of any size and various shapes within this table size.

The Beta Major has a heat plate which swings away from the operating position to clear the worktable for loading and unloading. After loading the work piece, and with the correct settings for temperature, pressure and dwell time, the heat plate is swung to the operating position with the handle provided. The cycle is started by simultaneously pressing the two white buttons on the front of the head, within ½ second. The controller operates the timer and the solenoid valve and thus the pneumatic cylinder. When the set time elapses the table is automatically lowered, enabling the head to be swung to the right. The worktable may then be unloaded and reloaded ready for another cycle.

The Beta Major is produced in one version, nominally 230-240V AC.

It is a simple operation to remove the worktable and replace it with one of a different size.

1.1 What did you receive?

The Beta Major has been placed in a cardboard box, and held in place with foam and banded onto a pallet, or as requested. The following articles should have been delivered:

- Beta Major complete with mains cable and plug
- Beta Major Operators Handbook
- Any extra items ordered

If there is any damage or any article is missing, please contact your supplier immediately.

1.2 Specifications of the Beta Major

The Beta Major is a pneumatically operated heat press for transfer printing and material fusing. It is ideal for high volume production with low operator fatigue.

The work area of the Beta Major is 15 x 20 in (38 x 50 cm) but machines may have, to special order, optional smaller sized interchangeable worktables of any size and various shapes within this table size.

Specifications

European Machine

	Major
Power consumption	2500 Watts
Power supply	230-240 Volts AC
Compressed air supply	7 bar max
Compressed air consumption	60 litres/min
Working temperature	70-235°C
Machine height	52 cm
Machine width	59 cm
Machine width, loading	79 cm
Machine depth	57 cm
Machine depth, loading	104 cm
Net weight	69 kg
Press pad dimensions	38 x 51 cm
Fuses	12.5A
A-weighted noise level	<70dB(A)

1.3 Safety

The **Beta Major** has been equipped with various safety features to ensure operator safety.

- a. **A thermal cut-out** on the heating element shuts off the power to the element if the temperature exceeds $235^{\circ}\text{C} \pm 15^{\circ}\text{C}$ ($455^{\circ}\text{F} \pm 27^{\circ}\text{F}$).
- b. **The time/temperature** controller has a built in facility giving error messages in the event of faults with the element heating and control system.
- c. **A two button** starting system ensures that the operator's hands are well away from the heat plate when the table rises.
- d. **Emergency stop button.**
- e. **The machine table** will only rise to pressing position when the heat plate is aligned with it due to a micro switch safety interlock

1.4 Safety Tips

Our customer service department has its own service engineers and, if required, maintenance and advice is available upon request.

- ◆ **The Beta Major** meets the European Legislation standard. Under normal conditions accidents are rare. However listed below are some practical points to ensure your safety.
 - **Always switch off** and isolate the mains supply (i.e. Remove plug) before undertaking any maintenance work.

Keep other people away from the machine during use.
 - **Ensure that there is** sufficient space around the machine. Cables and connections must not get jammed. Although the heat radiation of the press is low, there should be enough space for cooling down.
 - **Avoid contact** with the press element.
 - ◆ **DO NOT REMOVE THE TOP COVER UNLESS QUALIFIED TO DO SO** - touching internal parts is dangerous and may cause shock hazard.
 - ◆ **PROTECT THE MAINS CABLE** - damage to the mains cable may cause fire or shock hazard. When unplugging, hold by the plug only and remove carefully. Take care that the mains cable does not come into contact with the heat plate (or moving parts of the mechanism) during operation of the machine.
-

Safety Tips (cont.)

- ◆ **OPERATING AMBIENT TEMPERATURE RANGE** - the operating ambient temperature range is 32°F - 104°F, (0°C - 35°C) and humidity of 20 - 80%. This heat press is fitted with a thermal cut out to ensure that it cannot operate above 235°C ± 15°C (455°F ± 27°F).
- ◆ **MACHINE FUSES** - type: ultra-rapid (FF) fuses 1¼". (230 Vac max. 12.5 Amps)
- ◆ **WARNING - THIS APPARATUS MUST BE EARTHED (GROUNDED)**
- ◆ **CAUTION**
This machine gets hot whilst operating. Take care not to touch any surfaces that are labelled "Caution this plate is HOT".
- ◆ **MACHINE OPERATION**

Only suitably trained personnel should operate this machine.

This machine is designed to be operated by one operator only.

If any hissing noises of pneumatic leaks occur the machine must be immediately shut down for investigation.

If the air pressure is lost the table will lower. The machine should be switched off immediately or the situation could arise of the table rising under power without the operator's hands being safely on the two start buttons.

Contact your print media suppliers to ascertain whether fumes are given off during the process, and if so what precautions are needed for operator safety. These may include air extraction and/or masks for personnel.

Please refer to Page 14 for an illustration of the Beta Major machine.

2. Installation

2.1 Transport instructions

The machine comes to you in a cardboard box, and held in place with foam and banded onto a pallet. If you have to transport the machine at any time it is recommended that you use a similar box and packing methods. Please let the machine cool down, and remove the swing head handle.

2.2 Installing the machine

Take the machine out of the box, due to the weight of the machine we recommend that this be a 2-person task. Put the machine on a sturdy worktable close to a suitable electric socket and compressed air supply connection point within easy reach of the operator. There must be sufficient space for the machine's head to swing to the right until it hits the built in stop and back to the pressing position without creating trapping points against adjacent articles. Screw into place the head swing aside handle, which comes taped to the machine for safety during transport. (See **Page 14** for the position of the handle). Ensure that no items vulnerable to heat radiation are too close to the machine.

2.3 Electrical requirements

The Beta Major should be connected to the mains supply (nominally 230V AC) by the mains cable provided and a suitable plug. A qualified person should carry out this work.

The press is designed for 220-230 Volts AC 50/60 hertz and requires exclusive use of a power outlet rated for at least 13 Amps.

Ensure that the supply rating on the machine specification plate corresponds with your local supply and that the correct plug is fitted.

MAINS LEAD

The wires in this mains lead are coloured in accordance with the following code:

230 VAC	{	Green and Yellow	EARTH
		Blue:	NEUTRAL
		Brown:	LIVE

2.3A Wiring the mains plug

As the colours of the wires in the mains lead of this apparatus may not correspond with the coloured markings identifying the terminals in your plug, proceed as follows:-

1. **The wire** that is coloured green and yellow must be connected to the terminal in the plug that is marked by the letter E, or by the safety earth symbol coloured green, or green and yellow.
2. **The wire** coloured blue must be connected to the terminal that is marked with the letter N, (Neutral connector)
3. **The wire** coloured brown must be connected to the terminal that is marked with the letter L, (Live connector)
4. **NOTE:** Replacement of the mains cable must be done by a competent service engineer

2.4 Pneumatic requirements

The Beta Major and Minor should be connected through a filter regulator to a compressed air supply capable of delivering 60 litres/min at a pressure of 3.5-7 bar max. (2 cu. ft./min at 50-100 psi.). The press will not operate if the pressure drops below 3.5 bar (40 psi.). Double hose clips should be used on the delivery hose.

2.5 Adjusting the pressure

This press is fitted with a manually adjustable pneumatic pressure regulator on the right hand side of the front of the base. To adjust the operating air pressure, and therefore the pressure exerted by the press on the work, the regulator is unlocked by pulling forward the black plastic knob. Turning the regulator knob clockwise will increase the air pressure; turning anticlockwise will decrease the pressure. When the desired pressure is achieved the regulator is locked by pushing the knob back in.

3. How to Operate the Beta Major

3.1 Starting with the Beta Major

3.1.1 Turn on the Beta Major; the on/off switch is on the left side of the front of the swing head. Set the machine controls as necessary. See instructions for adjusting the pressure, **2.5**, and the operation of the time temperature unit, **Page 15**. When the set temperature is steady in the display the machine is ready to use.

3.2 Working with Heat Transfer Materials

3.2.1 Ascertain from the supplier of the transfer paper and/or the suppliers of the material, that the material to be used is suitable and has been prepared for transfer printing.

3.2.2 Obtain from the supplier of the transfer paper, or material to be used, the recommended temperature, time and pressure settings for the material to be worked on.

Approximate settings are usually within the following:-

180°C - 200°C (350°F - 400°F)	Heat Setting
10 - 30 seconds	Time Dwell Setting

3.2.3 Wait until the set temperature has been reached, signalled by the temperature on the controller display becoming steady at the desired figure. Swing the heat plate assembly to the right, using the handle on the left of the machine. Place the work piece on the pressure pad, removing all wrinkles. Place the transfer in the desired position. Swing the heat plate into the pressing position, to the stop, to 'make' the micro switch will enable the machine to cycle.

3.2.4 Start the sequence by pressing the two white buttons simultaneously (within ½ second). The worktable automatically rises up to the heat plate. (The process can be stopped at any time by using the "EMERGENCY STOP" button on the top of the press. This will automatically lower the worktable).

3.2.5 At the end of the set time, the worktable lowers to the loading position, allowing the head to be swung aside to permit unloading.

3.3 Material Fusing

3.3.1 When the press is to be used for the fusing of fusible interlining/heat bonding etc., ascertain from the supplier of the material to be used, the correct settings for time and temperature for the process.

Approximate settings are usually within the following:-

110°C - 170°C (250°F - 340°F)	Heat Setting
5 - 30 seconds	Time Dwell Setting

The method of operation for fusing is the same as for transfer printing.

During the fusing operation it will be found to be advantageous to lay a piece of PTFE cover material (the same size as the table), over the article being fused. This will act as an anti-stick barrier to prevent strike through of any surplus adhesive from the fusible materials adhering to the heat plate of the press.

Note: It is not advisable that this PTFE cover material be used when the press is being used for transfer printing.

3.4 Pressing Pad Assembly

The pressing pad normally supplied with this machine is silicone rubber. Alternatively a pad of foam with a NOMEX® cover may be supplied to special order. The pressing pad must be maintained in good condition at all times and replaced when showing signs of wear. A worn pressing pad will always affect the quality of printing/fusing. Do not insert items into the machine, which would tend to cut the pressing pad, i.e. buttons, pins, press-studs or zips.

IMPORTANT NOTE:

The pressing pad supplied with the machine is of the correct thickness. Using a thicker pad may invalidate your warranty.

3.5 Shutting Down

To shut down the machine when a cycle is finished, turn off the green illuminated rocker switch on the operator's left side of the machine head.

To temporarily interrupt the cycle, press the mode release button once.

Shutting Down (cont.)

To shut down in an emergency, press the red button on top of the machine head. If the emergency stop button is actuated, it will need to be unlocked by turning it anticlockwise before the machine will run again.

3.6 Fault Diagnosis

This machine has a built in fault diagnosis. The display may show the following:

1. **H-F**

If the element of the heat press, or the thermal cut-out go open circuit, after approximately 20 minutes the display will show “H-F”, and a buzzer will sound. If this display is seen, contact your machine supplier immediately.

2. **P-F**

If the probe goes open circuit, the display will show “P-F” immediately, and a buzzer will sound. Contact your machine supplier immediately.

CAUTION

In all fault conditions switch off the power to the machine and unplug the machine from the electrical supply before contacting your machine supplier.

3.7 Hints and Tips

Transfer Printing

Extra care should always be taken to ensure that transfer paper is placed print down onto the article, as mistakes will result in the heat plate becoming soiled with ink and spoiling following work.

When transfer printing, it may be found advantageous to cover the press pad with paper to prevent strike-through of surplus ink, particularly when printing thin material as surplus print on the pressing pad cover can also strike back on the following work.

Transfer Paper/Motifs Fail to Print Out Correctly

Check:-

1. **Heat and time** dwell settings are correct.

Hints and Tips (Cont.)

2. **Article** having transfers applied is locked in contact between pressing pad and heat plate.
3. **Pressing pad** is in good condition, is flat and making complete contact over the whole area of the heat plate. See Pressing Pad details.

“Ghosting” (Double Image) of Transfer Prints

Check:-

1. **Material being used** has been correctly heat set for transfer printing.
2. **Material being used** does not shrink during printing process, i.e. measure material before and after printing.
3. **Transfer paper** does not move after printing process upon lift off of the heat plate.
4. **If possible**, use adhesive coated paper, particularly to overcome fabric shrinkage.
5. **By pre-shrinking** of material in press before transfer printing.

4. Maintenance of the Machine

4.1 Daily Maintenance

For good press results it is important to keep the press surfaces clean. Wipe the surface of the heat plate with a dry non-abrasive cloth before use when the plate is cold.

When the heat plate is hot and is not in use, keep in the open position away from the silicone pad.

4.2 Periodic Maintenance

The grease nipples (No. 35 on the exploded diagram) in the rear of the swing head (**No. 12** on the exploded diagram) need to have a small amount of molybdenum grease pumped into them annually.

Periodically clean the Teflon coated heat platen with a non-abrasive piece of cloth. Stubborn stains may be cleaned, **when platen is cool,** with mineral spirits.

4.3 Cleaning

First unplug the machine. Clean the outside of the machine frequently with a clean, moist cloth. This may conveniently be carried out when the machine is cold.

To prevent soiling of substrate, periodic wiping of entire exterior machine, including platens, with a clean rag is recommended. If necessary, use mineral spirits for cleaning a **cold** machine. Since mineral spirits are flammable, use precautions at all times and keep away from sparks, flames or hot heat platen.

5. Machine Drawings and Diagrams

On the following pages are the schematic diagrams for the Beta Major machine.

5.1	General Layout.....	Page 14
5.2	Control Unit – Operation.....	Page 15
5.3	Exploded Diagram and Parts List.....	Page 16
5.4	Electrical Diagram.....	Page 17
5.5	Controller Electrical Diagram.....	Page 18
5.6	Pneumatic Schematic.....	Page 19

5.1 General Layout of the Major and Minor Machine

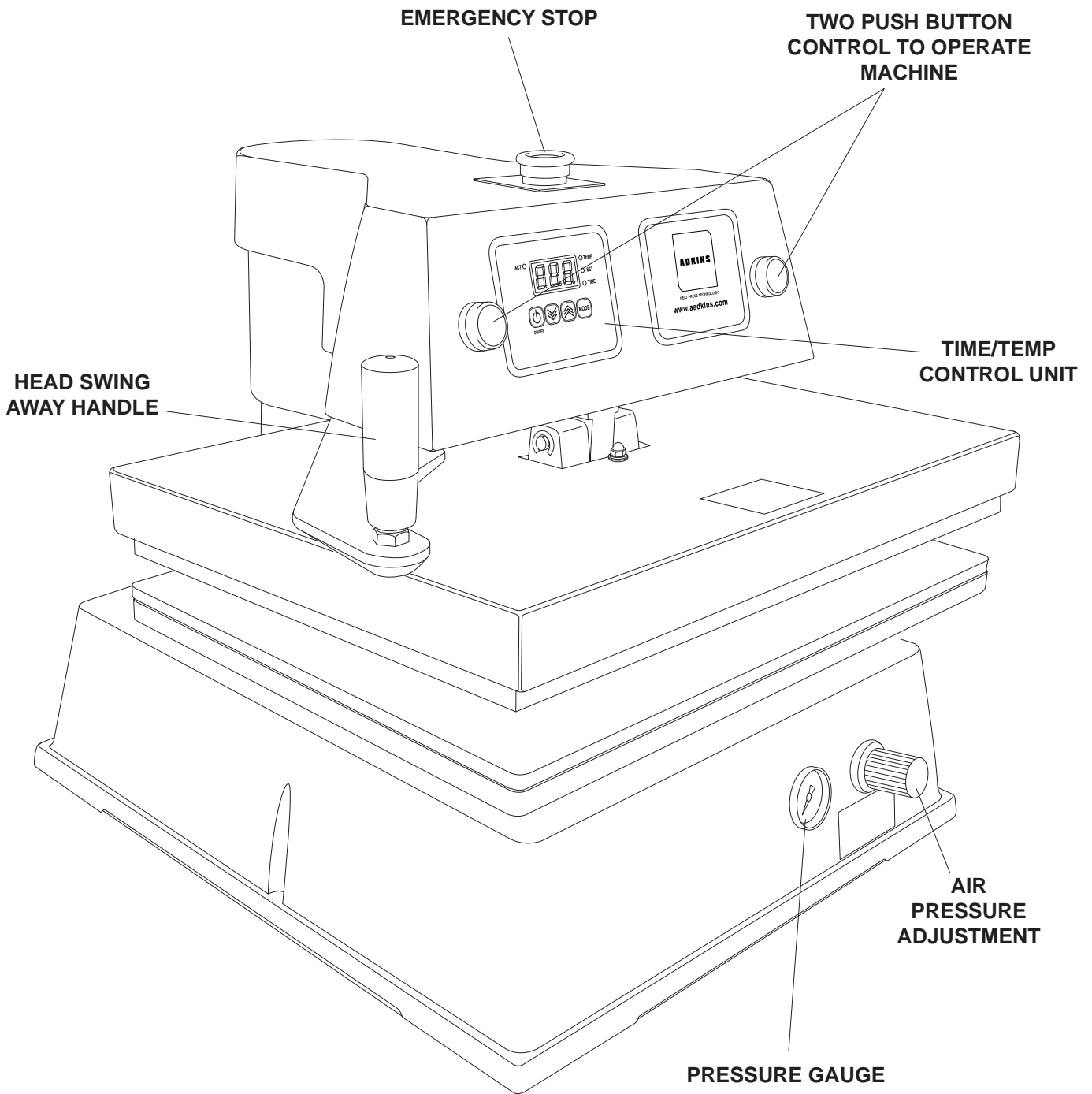

5.2 Operation Of Control Unit, Setting Time and Temperature

(The table must always be in the down position before the controller is set)



Setting Temperature

1. Switch on Press; Display and 'TEMP' indicator will light up.
2. Press 'MODE' button to select 'Set' on indicator.
3. The Display will start flashing.
4. Use the 'UP' and 'DOWN' arrow buttons to set the required temperature.
5. When you have set the required temperature the Display will stop flashing and the 'SET' indicator will go out.
6. Press the 'ON/OFF' button to start the Press heating to the selected temperature. The 'ACT' indicator will light up.



Setting Time

1. Switch on Press; Display and 'TEMP' indicator will light up.
2. Press 'MODE' button twice to select 'SET' and 'TIME' on indicator.
3. The display will start to flash.
4. Use the 'UP' and 'DOWN' arrow buttons to set the required time.
5. When you have selected the required time the Display will stop flashing and the 'SET' and 'TIME' indicators will go out.
6. Press the 'ON/OFF' button to start the Press. The 'ACT' indicator will light up.

5.3 Exploded Diagram and Parts List

No.	Description	Part No.	Qty.
1	Emergency stop button complete	AME340	1
2	Cycle start buttons	AME311	2
3	Instrument cover	AME111	1
4	Controller complete	BMC322/COMP	1
4a	Front controller LED (buzzer board)	BMC322/A	1
4b	Back controller power board	BMC322/B	1
4c	Controller back plate	AM628/C	1
4d	Green button controller	BM322/YF	1
5	Green rocker switch	BM448	1
6	Overlay R/H Adkins Major fascia	BM629	1
7	Pivot post top cap	AMC106	1
8	Micro switch cam	AMC373	1
9	Pivot "o" ring	AMC204	2
10	Swing arm handle	BMC508	1
11	Arm	AMC110	1
12	Swing head	AMC103	1
13	Micro switch	AM312	1
14	Pivot post stop color	AMC107	1
15	Insulation cover dark grey	AMC27	1
16	Terminal box	BMC460/3	1
17	Terminal box gland and nut	BMC460/2	1
18	Standard fuse holder	BMC468	2
19	1/8 standard BSP grease nipple	BMC201	2
20	Overlay L/H touch pad fascia	AM628	1
21a	PTFE ring probe	FP3057/5	1
21b	PTFE bullet probe	BM478/PTFE	1
22	Thermal cut out	BM338	1
23	PTFE pillar	AMC207	4
24	Guide post insulator	BM247	1
25	Hollow guide post	AMC332	1
26	Yoke	AMC108	1
27	Yoke pin	BMC22/C	1
28	Adaptor plate	AMC353	1
29	15 x 20 Heat plate (inc loom)	BMC460/COMP	1
30	Non adhesive silicone pad 38 x 50 cm	BMC341	1
31	Mains lead Maxi/Major 2 pin	BMC619	1
	Mains lead Maxi/Major 3 pin	BMC617	1
32	Major table 15 x 20	AMC113	1
33	Socket for mains lead	BMC426	1
34	Base	AMC101	1
35	Quick release socket check unit	AMC352/O	1
36	Fibre washer	AM342	1
37	Capacitor	AM323	1
38	Solenoid valve comp with fitting	AMC352/D	1
39	Table spigot	AMC114/ME	1
40	Compression spring	AMC201A	3
41	Anti rotation pin	AMC117	1
42	Olite bush	BMC321/S	1
43	Piston and sleeve	AMC104	1
44	Piston "o" ring	AMC203	2
45	Piston bore sleeve	AME112	1
46	Cylinder end cap	AME105	1
47	Base board	BM335	1
48	Rubber foot	SW33	4
49	Foam gaiter	AM327	1
50	Gauge	AMC352/C	1
51	Regulator	AM352U/A	1
52	Exhaust valve	AMC352/M	1
53	Bulk head	AMC352/I	1
54	Male adaptor	AMC352/N	1
55	Emergency stop plastic label	AM325	1
56	Live electric connections label	MPC6549	1
57	Caution live fuse label	BMC470	1
58	Caution hot label	MPC6548	1
59	Max pressure label	AMC326	1
60	12.5 Amp fuse	BM356	2

* Parts for older machines
* Controller complete

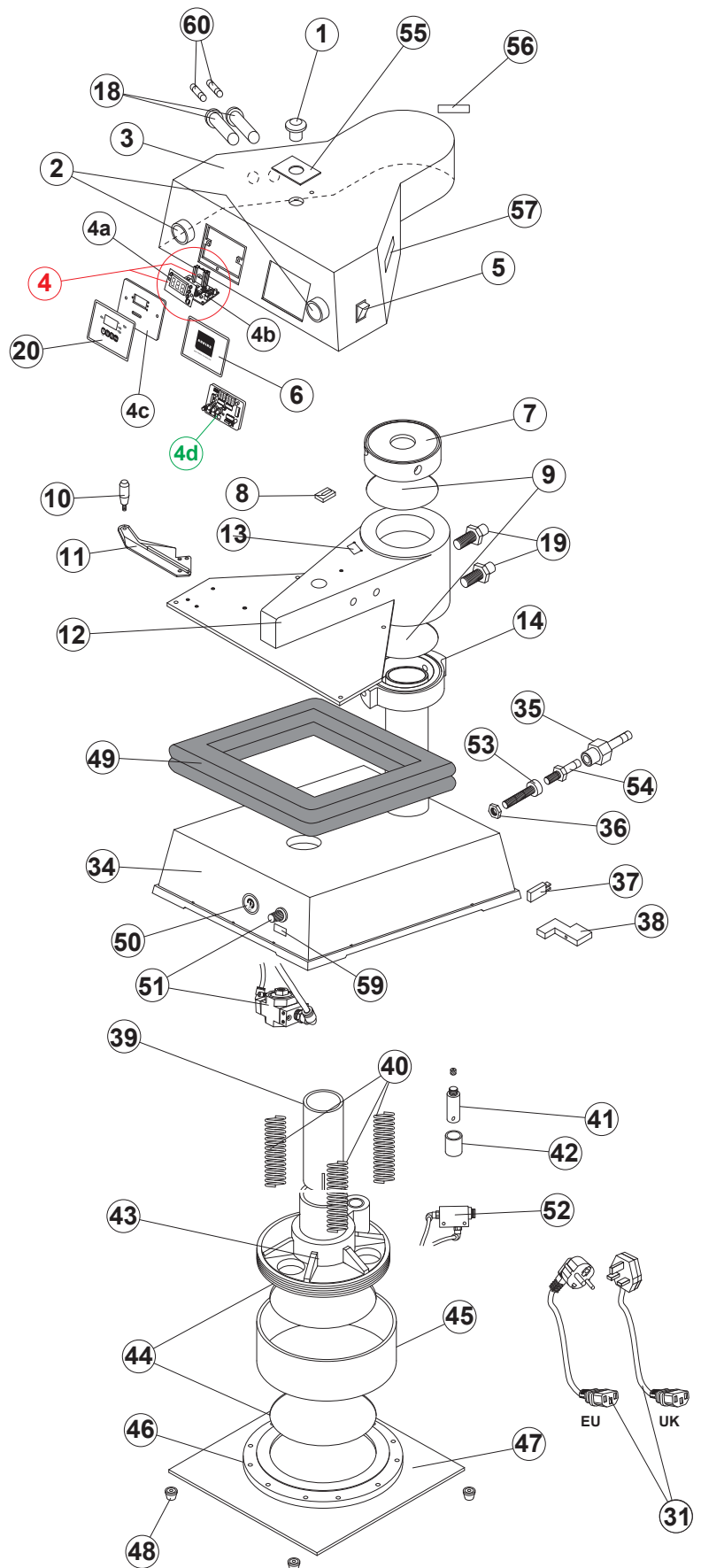
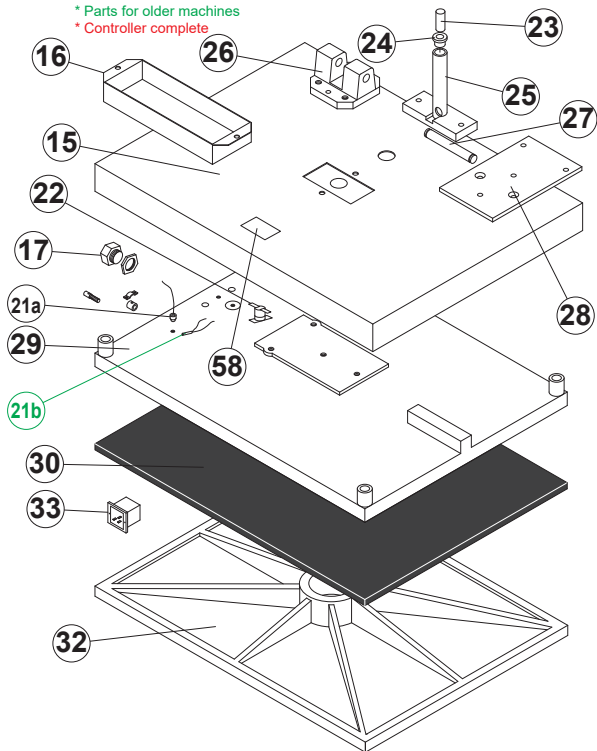

5.4 Electrical Diagram

ES = Emergency Stop
PB = Push Button Cycle Start
SW 1 = Mains On/Off Switch
SW 2 = Swing Arm Switch
T.T.U. = Time. Temperature. Unit

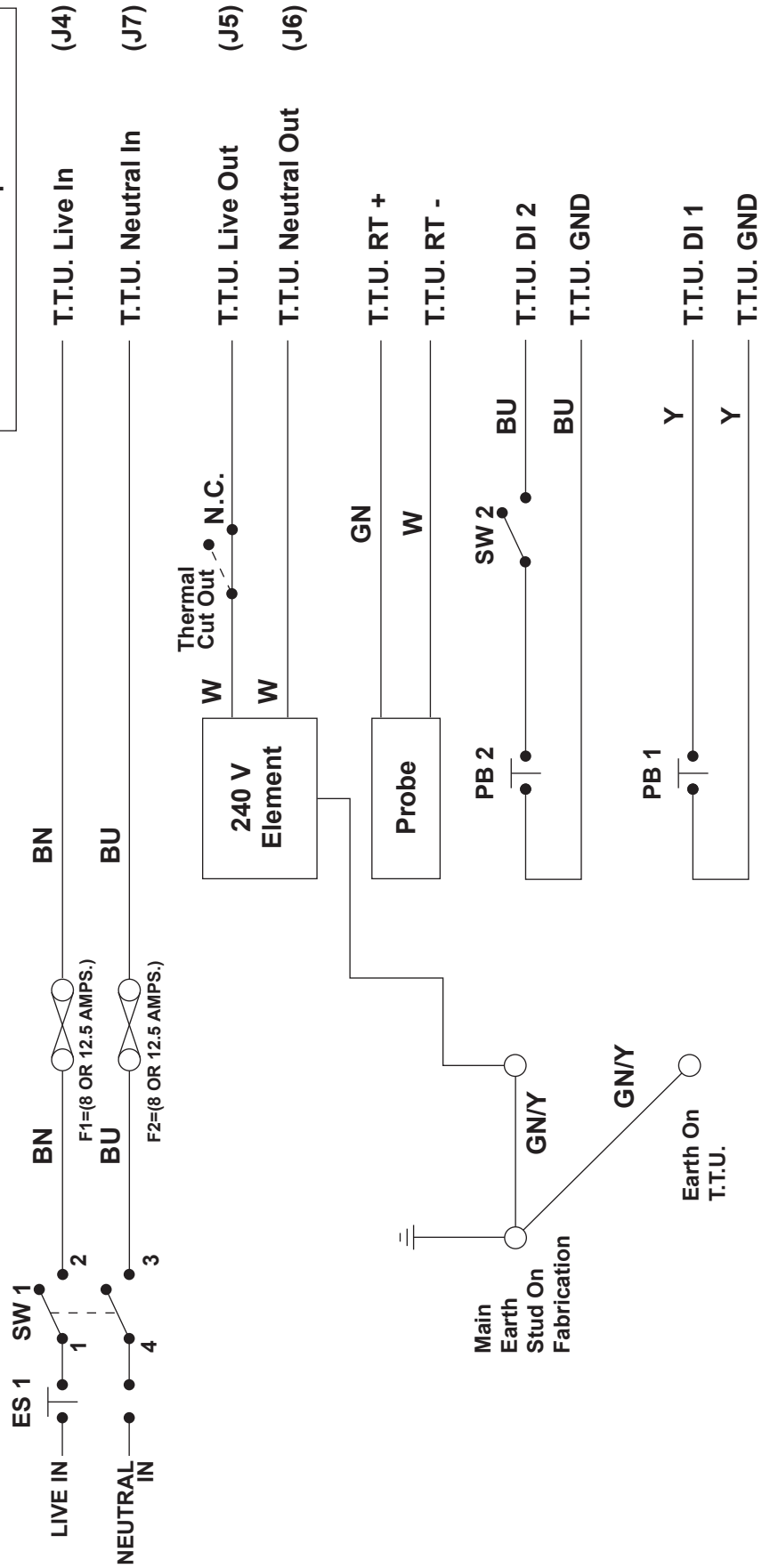

5.5 Controller Electrical Diagram

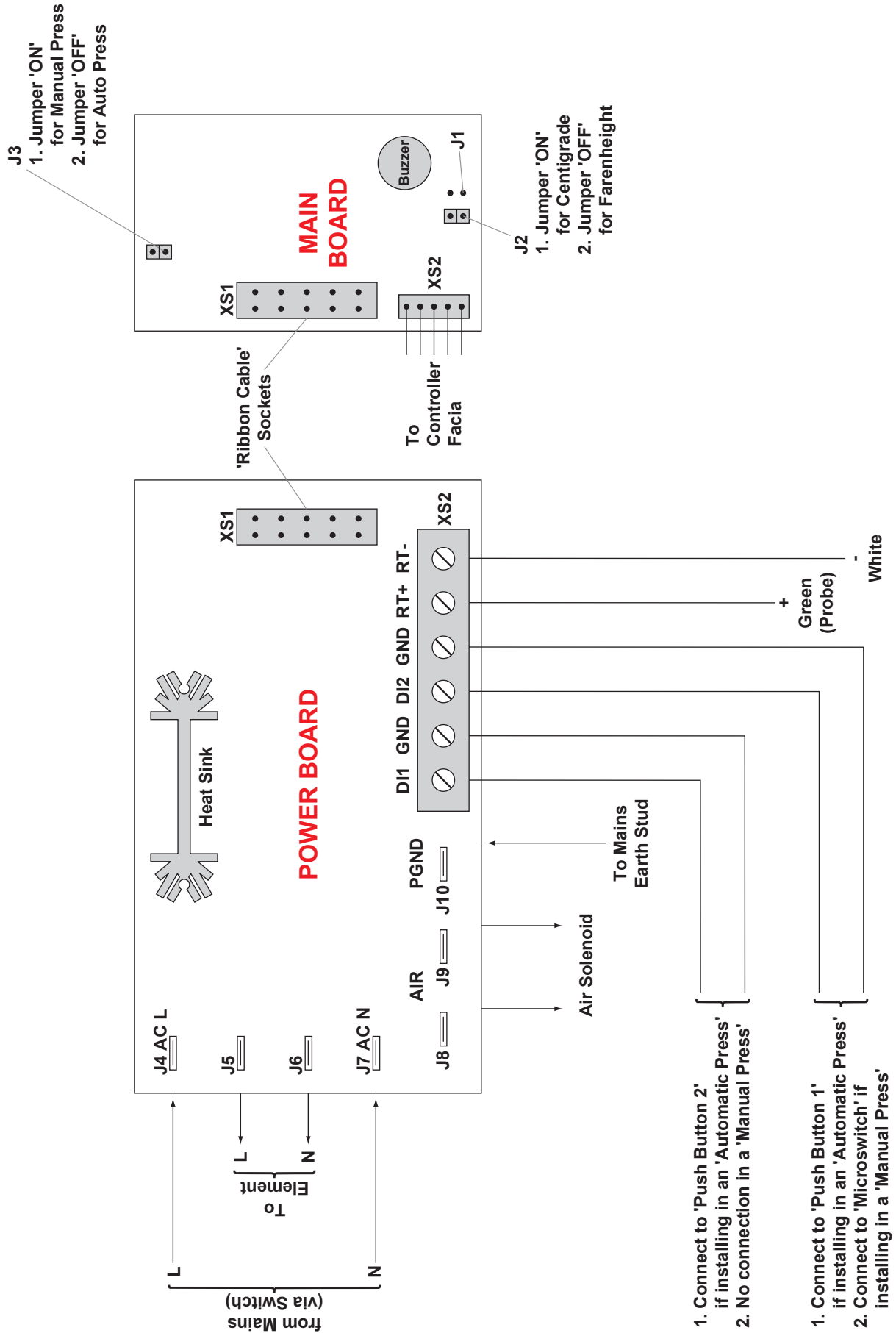

5.6 Pneumatic Schematic

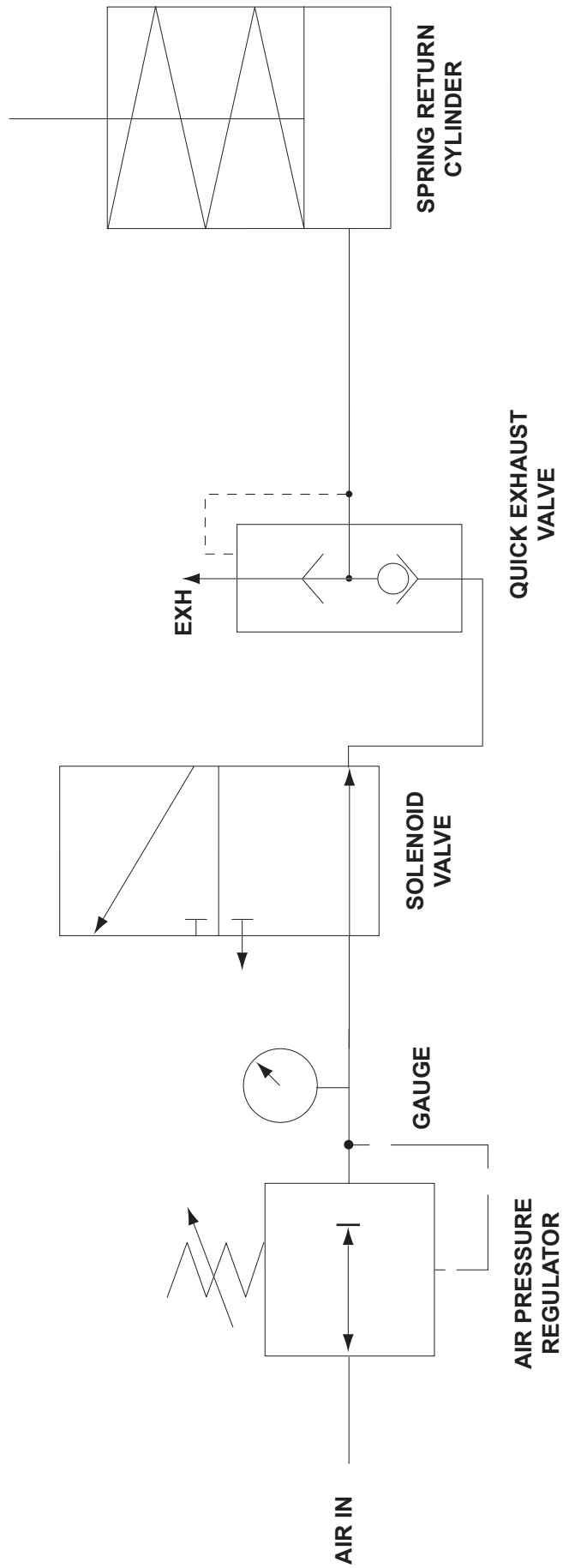

6. Design Change

With the policy of constant improvement and/or modification to meet changing conditions, the right is reserved to change the design and/or specifications at any time without prior notification, and therefore specifications may vary and not be in accordance with this manual.

7. Guarantee (Limited Warranty)

A. Adkins & Sons Limited warrants that the press is free from defects in material and workmanship for a period of 12 months from the date of supply. The machine comes with a lifetime warranty on the heating element, one year warranty on parts and 90 days labor.

This warranty covers all parts to repair the defects, except when damage results from misuse or abuse, accident, alteration or negligence or when a machine has been improperly installed.

If a press covered by warranty should need to be returned to the factory for examination and repair, if on-site component replacement is not possible, A. Adkins & Sons Limited will make every effort to repair the customers press. The warranty will only be effective when A Adkins & Sons Limited authorises the original purchaser to return the machine to the factory and only when the product upon examination has proven to be defective.

Should in our opinion any part of this press be defective in materials or workmanship, it will be replaced or repaired free of charge, provided that the press has been installed and operated in the correct manner and not subjected to misuse. If A. Adkins & Sons Limited authorise a replacement press, the warranty of the replacement press shall expire on the anniversary date of the original machines invoice to the customer.

In order for this warranty to be effective, no return of machine or parts may be made without prior factory authorisation. (This will exclude any travelling and/or carriage costs which will be charged at our discretion).

This is the sole warranty given by the company; there are no warranties, which extend beyond the description on the face hereof. The seller disclaims any implied warranty of merchantability and/or any implied warranty of fitness for a particular purpose; the buyer agrees that the goods are sold "as is". A. Adkins & Sons Limited does not warrant that the functions of the press will meet the customer's requirements or expectations. The entire risk as to use, quality and performance of the press lies with the customer. (No claim of any kind shall be greater than the sale price of the product or part to which the claim is made).

In no event will A. Adkins & Sons Limited be liable for any injury, loss or damage, including loss of profits, destruction of goods or any special, incidental, consequential or indirect damages arising from the use of the press or accompanying materials. This limitation will apply even if A. Adkins & Sons Limited or its authorised agent had been advised of the possibility of such damage.

A. ADKINS & SONS LIMITED
DECLARATION OF CONFORMITY



<p>Application of Council Directives:</p> <p>Standards to which Conformity is Declared:</p>	<p>Machinery, Low Voltage. E.M.C.</p> <p><u>BS EN ISO 12100:2010</u> - Safety of machinery: Basic Technology, Principles of Design. <u>BS EN 60204-1:2006+A1:2009</u> - Safety of machinery: Electrical Equipment of Machines <u>BS EN 60529:1992-A2:2013</u> - Degree of protection provided by enclosures. <u>BS EN ISO 13850:2015</u> - Safety of Machinery: Emergency Stops. <u>BS EN ISO 141211:2007</u> - Safety of Machinery: Principles for Risk Assessment. <u>BS EN 55011:2016+A1:2017</u> - Class A Group 2 Equipment - EMC Emissions. <u>BS EN ISO 61000-6-4:2007+A1:2011</u> - EMC Conducted Emissions. <u>BS EN ISO 61000-6-2:2005</u> - EMC Immunity. <u>Low Voltage Directive 2014/35/EC</u> - Including DIN EN 61557-1, -4 and -5. <u>Electro Magnetic Interference Directive 2014/30/EC</u> - Including DIN EN 61000-6 series of standards.</p>
<p>Manufacturer's Name:</p> <p>Manufacturer's Address:</p>	<p><u>A. Adkins & Sons Limited</u></p> <p>High Cross, 18 Lancaster Road, Hinckley, Leicester, LE10 0AW, United Kingdom.</p>
<p>Type of Equipment:</p>	<p>Beta Major Heat Press</p>
<p>Standards Compliance:</p>	
<p>Model Number:</p>	<p>.....</p>
<p>Serial Number:</p>	<p>.....</p>
<p>Year of Manufacture:</p>	<p>.....</p>

I, the undersigned, hereby declare that the equipment specified above conforms to the above directives and standards.

Place: Hinckley, United Kingdom

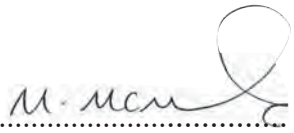
Signature: 

Date:

Full Name: Marie McMahon
 Position: General Manager