

ADKINS

ALPHA INDUSTRIAL FLATBED SERIES 7



Operators Handbook

©2017 a.adkins and sons limited. all rights reserved

Copyrights

©2017, **A. Adkins & Sons Limited**, High Cross, Lancaster Road, Hinckley, Leicestershire. No part of this publication may be reproduced by any means without the prior written permission of A. Adkins & Sons Limited.

Alpha Industrial Flatbed Series 7 Transfer Press is a registered trademark of A. Adkins & Sons Limited.

Please read this manual carefully and keep it with your machine at all times for reference.

Preface

Dear User

Welcome to the growing group of Alpha Industrial Flatbed Series 7 Transfer Press users. The product you have purchased has been carefully designed and manufactured to ensure that you, the user, will gain the maximum benefit.

All A. Adkins products are specifically designed to ensure ease of use with particular attention to safety requirements.

Should you discover any fault or damage upon receipt of this product, you should immediately contact your supplier.

Contents

1.	Introduction Alpha Industrial Flatbed Series 7 Transfer Press	1
1.1	What did you receive?	2
1.2	Specifications of the Alpha Industrial Flatbed Series 7 Transfer Press	3
1.3	Safety	4
1.4	Safety tips	4
1.5	The possibility to defeat or circumvent safety measures	5
2.	Installation	6
2.1	Pre-installation instructions	6
2.2	Pre-installation electrical requirements	7
2.3	Pre-installation compressed air requirements	7
2.4	Installing the machine	8
2.5	Electrical requirements	9
2.6	Pneumatic requirements	9
2.7	Adjusting the pressure	10
3.	How to operate the Alpha Industrial Flatbed Series 7 Transfer Press	11
3.1	Starting with the Alpha Industrial Flatbed Series 7 Transfer Press	11
3.2	Working with heat transfer materials	11
3.3	Material fusing	12
3.4	Pressing pad assembly	13
3.5	Shutting down the machine	13
3.6	Hints and tips	14
4.	Maintenance of the machine	16
4.1	Daily maintenance	16
4.2	Weekly maintenance	16
4.3	Cleaning	16
5.	Machine drawings and diagrams	17
5.1	General layout	18
5.2	Control panel operation	19
5.3	Control unit operation	21
5.4	Exploded diagram and parts list	22
5.5	Electrical diagram	23
5.6	Pneumatic schematic	24
5.7	Machine assembly	25
6.	Design change	26
7.	Guarantee (limited warranty)	27
	Declaration of conformity	28

1. Introduction Alpha Industrial Flatbed Series 7 Transfer Press

The Alpha Industrial Flatbed Series 7 Transfer Press is a pneumatically operated heat press for transfer printing and material fusing it is ideal for high volume production with low operator fatigue.

The fusing areas for the Alpha Industrial Flatbed Series 7 Transfer Press are:

Large machine - 1200 x 1700 mm (*47 x 67 in*)

Standard machine - 1000 x 1200 mm (*39 x 47 in*)

The Alpha Industrial Flatbed Series 7 Transfer Press is operated such that in the normal 'stand-by' mode, the heat plate is retained in the elevated position by compressed air, applied to the appropriate ports of the acting cylinder.

Pressing either of the green buttons on the control boxes (located on the front of the frame) will initiate an automatic pressing cycle. This is only possible when the sliding table is positioned correctly to align the work under the heat plate, at which time the guard flap is manually closed. Micro switches then detect the closure of the flap and apply power to the pneumatic driver board. The pneumatic driver board then applies power to the intermediate relay, which in turn provides power to both the pneumatic solenoid valve and the digital timer, which allows the solenoid valve to open the intake door. Air is now applied to the other cylinder ports, forcing the heat plate onto the table and initiating the automatic pressing sequence.

After expiry of the pre-set time the digital controller sends a signal to the pneumatic driver board, the driver board then cuts the power for the downstream line, deactivating the solenoid valve, which in turn closes the intake door. The cylinder then returns the heat plate to its elevated position.

The Alpha Industrial Flatbed Series 7 Transfer Press is produced nominally as:

Large machine Three phase – 5 lines (neutral + earth) 380 VAC

Standard machine Three phase – 5 lines (neutral + earth) 380 VAC

1.1 What did you receive?

The **Alpha Industrial Flatbed Series 7 Transfer Press** has been placed in a crate and banded onto a pallet, for safe transportation. The following articles should have been delivered:

- Alpha Industrial Flatbed Series 7 Transfer Press.
- Alpha Industrial Flatbed Series 7 Transfer Press Operators Handbook.
- Any extra items ordered.

If there is any damage or any article is missing, please contact your supplier immediately.

1.2 Specifications of the Alpha Industrial Flatbed Series 7 Transfer Press

The Alpha Industrial Flatbed Series 7 Transfer Press is a pneumatically operated heat press for transfer printing and material fusing it is ideal for high volume production with low operator fatigue.

The fusing areas for the Alpha Industrial Flatbed Series 7 Transfer Presses are:

Large machine - 1200 x 1700 mm (47 x 67 in)

Standard machine - 1000 x 1200 mm (39 x 47 in)

Specifications

Power consumption:

Large machine 15 kW

Standard machine 9.0 kW

Power supply

Large machine 380 Volts AC - 23 Amps

Standard machine 380 Volts AC - 14 Amps

Dimensions:

Large machine: 1752 (L)x 2236 (W)x 1580 (H) mm
(69 (L)x 88 (W)x 62 (H) in)

Standard machine: 1553 (L)x 1801 (W)x 1300 (H) mm
(61 (L)x 71 (W)x 51 (H) in)

Dimensions export packed:

Large machine 2240 (L)x 1820 (W)x 2090 (H) mm
(88 (L)x 71.5 (W)x 82 (H) in)

Standard machine 1700 (L)x 1750 (W)x 1800 (H) mm
(67 (L)x 69 (W)x 71 (H) in)

Press pad dimensions

See above

Net weight:

Large machine 1,114 kg (2,456 lbs)

Standard machine 782 kg (1,725 lbs)

Weight Export Packed:

Large machine 1,390 kg (3,064 lbs)

Standard machine 1,004 kg (2,213 lbs)

Compressed air supply:

Large machine 5 bar (72.5 Psi)

Medium machine 4 bar (58 Psi)

Max compressed air consumption 135 litres/min (7.32 Cu in/min)

Maximum temperature 225°C ± 0.5% (437°F ± 0.5%)

Display timer range 0 – 999 sec

1.3 Safety

The Alpha Industrial Flatbed Series 7 Transfer Press has been equipped with various safety features to ensure operator safety.

- a. **A thermal cut-out** on the heating element shuts off the power to the element if the temperature exceeds $225^{\circ}\text{C} \pm 0.5\%$ ($437^{\circ}\text{F} \pm 0.5\%$).
- b. **Emergency stop button.**
- c. **The heat plate** will only lower to pressing position when the table is aligned with it due to a micro switch safety interlock.

1.4 Safety tips

Our customer service department has its own service engineers and, if required, maintenance and advice is available upon request.

- ◆ **The Alpha Industrial Flatbed Series 7 Transfer Press** meets the European Legislation standard. Under normal conditions accidents are rare. However listed below are some practical points to ensure your safety.
 - **Always switch off** and isolate air and mains supply (i.e. Remove plug) before undertaking any maintenance work. Always bear in mind that the machine could still be **hot** and **compressed air** may be stored in the machine's reservoir.
 - **Keep other people** away from the machine during use.
 - **Ensure that there is** sufficient space around the machine. Cables and connections must not get jammed. Although the heat radiation of the press is low, there should be enough space for cooling down.
 - **Avoid contact** with the press element.
 - ◆ **DO NOT REMOVE THE TOP COVER UNLESS QUALIFIED TO DO SO** - touching internal parts is dangerous and may cause shock hazard.
 - ◆ **PROTECT THE MAINS CABLE** - damage to the mains cable may cause fire or shock hazard. Take care that the mains cable does not come into contact with the heat plate (or moving parts of the mechanism) during operation of the machine.
 - ◆ **OPERATING AMBIENT TEMPERATURE RANGE** – the operating ambient temperature range is $0^{\circ}\text{C} - 35^{\circ}\text{C}$, ($32^{\circ}\text{F} - 104^{\circ}\text{F}$) and humidity of 20 - 80%. This heat press is fitted with a thermal cut out to ensure that it cannot operate above $225^{\circ}\text{C} \pm 0.5\%$ ($437^{\circ}\text{F} \pm 0.5\%$).
-

Safety tips (cont.)

- ◆ **MACHINE FUSE** – Please refer to **section 1.2** ‘Specifications of the Alpha Industrial Flatbed Series 7 Transfer Press.’
- ◆ **WARNING - THIS APPARATUS MUST BE EARTHED (GROUNDED).**
- ◆ **CAUTION**
This machine gets hot whilst operating. Take care not to touch any surfaces that are labelled “Caution this plate is HOT”.
- ◆ **MACHINE OPERATION**
Only suitably trained personnel should operate this machine.

This machine is designed to be operated by one operator only.

If any hissing noises of pneumatic leaks occur the machine must be immediately shut down for investigation.

Contact your print media suppliers to ascertain whether fumes are given off during the process, and if so what precautions are needed for operator safety. These may include air extraction and/or masks for personnel.

Please refer to Section 5.1 for an illustration of the Alpha Industrial Flatbed Series 7 Transfer Press.

1.5 The possibility to defeat or circumvent safety measures

The owner shall take account of the possibility and incentive to defeat or circumvent safety measures, for example:

- a) **The safety measure slows down production,** or interferes with any other activities or preferences of the user.
- b) **The safety measure is difficult to use.**
- c) **Persons other than the operator** are involved.
- d) **The safety measure is not recognised** by the user or is not accepted as suitable for its function.

The machine has been factory tested to perform its normal function. The owner and operator **MUST ENSURE** that the machine is subject to neither mis-function nor malfunction, beyond the normal use of transfer printing fusing and in particular **ALL** of the safety measures outlined in this handbook and incorporated into the design of the machine shall not be over-ridden in any way.

2. Installation

2.1 Pre-installation instructions

The machine should be installed to supplier specifications and as such will require that certain pre-installation tasks should be met/ performed prior to installation:

1. **The machine is designed for** use in a light industrial environment. The machine must be housed inside a building with a dry environment and it must not be exposed to the elements.
2. **The operating ambient temperature range** is 0°C - 35°C, (32°F - 104°F) and humidity of 20 - 80%. This heat press is fitted with a thermal cut out to ensure that it cannot operate above 225°C ± 0.5% (437°F ± 0.5%).
3. **Building access should allow the machine** to be placed in its final position without dismantling the machine further. The largest assembly is the frame.

The export packed (gross) weight is:

Large machine – 1,390 kg (3,064 lbs)

Standard machine – 1,004 kg (2,213 lbs)

4. **Personnel and suitable lifting equipment** should be made available to off load the machine from our delivery vehicle and move it to its working location i.e. fork lift truck, pallet truck etc.

2.1.1 ELECTRICAL AND PNEUMATIC WORK SHOULD BE UNDERTAKEN BY THE CUSTOMER PRIOR TO COMMISSIONING OF THE MACHINE:

It is the customer's responsibility to ensure that the machine is connected to the compressed air and a suitable electrical supply.

It is expected that airline installation and wiring to the machine will be completed prior the agreed engineer's visit **BUT FOR SAFETY REASONS IT IS IMPORTANT** that supplies remain isolated and the machine is not operated before an engineer completes the commissioning procedure.

2.2 Pre-installation electrical requirements

The Alpha Industrial Flatbed Series 7 Transfer Press is designed to operate using:

Large machine

- Three phase – 5 lines (neutral + earth) 380 Volts AC. Nominal load current is 23 A.

N.B. The three phases may be connected by any sequence.

Standard machine

- Three phase – 5 line (neutral + earth) 380 Volts AC. Nominal load current is 14 A.

NB: The machine is **NOT** supplied with a mains supply cable. The customer or his agent should provide the mains supply cable. Termination is via a switched fuse box mounted on the main frame of the machine.

2.3 Pre-installation compressed air requirements

A supply of compressed air needs to be available continually. Maximum pressure supplied to the machine should be 5-5.5 bar (*75-80 Psi*).

Typical maximum consumption is:

Large machine – 210 litres/min (*7.32 Cu in/ min*).

Standard machine – 170 litres/min (*7.32 Cu in/ min*).

Connection is via 12 mm external and 8 mm internal (*0.47 in external and 0.31 in internal*) bore hose to a pressure regulator assembly mounted on the main frame. The supply hose is provided by the customer or his agent and should be attached with two hose clips for safety.

2.4 Installing the machine

The Alpha Industrial Flatbed Series 7 Transfer Press should be set onto a solid foundation, packing feet where necessary to ensure that it is firm and level in all directions. The table support bars should be set by a skilled person prior to use of the machine to avoid printing/fusing problems.

Please refer to Section 5.7 for further information about Installing Machine.

2.5 Electrical requirements

The Alpha Industrial Flatbed Series 7 Transfer Press requires a three phase mains supply and is connected to the machine via a switched fused isolating box.

NB. It is essential that this machine be connected to an effective electrical earth to ensure safety of users.

Supply requirements are as follows:

Alpha Pneumatic Series 7 Industrial (Large machine) 120 x 170cm (47 x 67 in)				
Voltage	Phase	Hz.	Nominal heating power	Nominal full load current = 23 A
380 V	three phase, (earth + neutral)	50-60	15 kW (3 elements, 5 kW each)	7.6 A per phase

Alpha Pneumatic Series 7 Industrial (Standard machine) 100 x 120cm (39 x 47 in)				
Voltage	Phase	Hz.	Nominal heating power	Nominal full load current = 14 A
380 V	three phase, (earth + neutral)	50-60	9.0 kW (3 elements, 3 kW each)	14 A per phase

2.6 Pneumatic requirements

A permanent supply of compressed air is required whilst the machine is in normal use. The air supply, not exceeding 1Mpa=10.2 kgf/cm² (145 P.S.I.) is connected via a pressure regulator valve located on the main frame of the machine.

See Section 5.6 Pneumatic Schematic.

2.7 Adjusting the pressure

- 2.7.1 **Turn on air supply to press** and adjust pressure regulator screw until the gauge indicates the required level minimum of 4 kgf/cm² (*55psi*), maximum 8 kgf/cm² (*113psi*).

N.B:

The pressure shown by the gauge determines the amount of pressure exerted by the heat plate during the printing/fusing operation, i.e. if less or more pressure is required; adjust the air pressure regulator adjusting screw accordingly.

2.7.2 RESTRICTOR VALVES

Restrictor valves have been fitted to the pneumatic cylinders – see ‘Pneumatic Circuit’.

CAUTION:

To set Restrictor Valves, this must be done with guard removed. **EXTREME CAUTION** should be taken by Qualified Persons whilst making the adjustments. The guard should be refitted before using the machine.

DO NOT REMOVE THE ELECTRICAL HOUSING GUARD WHEN MAKING THIS ADJUSTMENT

These valves are adjustable and control the speed of approach and lift off of the heat plate from the pressing pad upon completion of the printing cycle. To adjust, unfasten locking nut on adjusting screw, turn adjusting screw clockwise to decrease speed anticlockwise to increase speed, tighten locking nut when desired speed is achieved.

Restrictor valve must be set and balanced on the cylinder to ensure even movement of the heat plate to and from the pressing pad.

N.B.

Adjustment of the cylinder speed is essential to ensure that the transfer paper does not become dislodged during movement of the heat plate. It is advisable where possible to use transfer papers with ‘tack’ adhesive to reduce the possibility of displacement of the transfer paper during heat plate lift off.

3. How to operate the Alpha Industrial Flatbed Series 7 Transfer Press

3.1 Starting with the Alpha Industrial Flatbed Series 7 Transfer Press

3.1.1 Turn on the Alpha Industrial Flatbed Series 7 Transfer Press; The power switch is situated on the control box which is attached to the side of the machines main body. Set the machine controls as necessary. See instructions for setting automatic or manual modes **Section 5.2**, adjusting the pressure **Section 2.7**, and operation of the time/ temperature unit, **Section 5.3**. When the set temperature is achieved the machine is ready to use.

3.2 Working with heat transfer materials

3.2.1 Ascertain from the supplier of the transfer paper and/or the suppliers of the material, that the material to be used is suitable and has been prepared for transfer printing.

3.2.2 Obtain from the supplier of the transfer paper, or material to be used, the recommended temperature, time and pressure settings for the material to be worked on.

Approximate settings are usually within the following:-

180°C - 200°C (350°F - 400°F)	Heat Setting
10 - 30 seconds	Time Dwell Setting

3.2.3 Ensure heat controller/dwell timer/air pressure is correctly set as already described.

3.2.4 Pull out sliding table to full extent.

3.2.5 Place the recycled cotton pad onto the table.

3.2.6 Place material to be printed onto the cotton pad on the pressing pad and lay transfer paper onto the material (print side down).

3.2.7 Push in the sliding table slowly to full extent, ensuring that the paper and the material are not displaced during this movement.

Working with heat transfer materials (cont.)

- 3.2.8** After pushing in the sliding table, and depending on whether automatic table operation mode or manual table operation mode is selected, the machine will then either complete a pressing cycle (automatic mode) or user will need to press the green cycle start button, located on the left or right hand sides of the front of the table support arm, to complete a pressing cycle (manual mode). For more information on how to select/set automatic or manual mode please see **Section 5.2**.
- 3.2.9** Pull out the sliding table and remove the transfer paper from work piece (using recommended manufacturer's guidelines).

3.3 Material fusing

- 3.3.1** When the press is to be used for fusing of fusible interlinings/heat bonding etc. it is advisable to lay a piece of PTFE cover material onto the pressing pad, preferably of the same size as the pad to act as a base for fusing operation. The parts to be fused are then laid onto this cover.
- 3.3.2** A further piece of PTFE cover material is laid over the pressing pad covering the whole of the parts to be fused.
- 3.3.3** The PTFE covers will then act as an anti-stick barrier to prevent strike-through of any surplus adhesive from the fusible interlining/adhesive coated bonding material and so prevent any fouling of the heat plate and/or pressing pad during the fusing operation.

Approximate settings are usually within the following:-

110°C - 170°C (250°F - 340°F)	Heat Setting
5 - 30 seconds	Time Dwell Setting

The method of operation for fusing is the same as for transfer printing.

- 3.3.4** Ensure heat controller/dwell timer/air pressure is correctly set, as already described.
- 3.3.5** Pull out sliding table to full extent.
- 3.3.6** Lay parts to be fused onto the PTFE cover of the pressing pad (adhesive face down) into the required position and cover with further PTFE cover – as described above.
- 3.3.7** Push in sliding table slowly to full extent ensuring that the materials are not displaced during this movement.
- 3.3.8** After pushing in the sliding table, and depending on whether automatic table operation mode or manual table operation
-

Material fusing (cont.)

mode is selected, the machine will then either complete a pressing cycle (automatic mode) or user will need to press the green cycle start button, located on the left or right hand sides of the front of the table support arm, to complete a pressing cycle (manual mode). For more information on how to select/set automatic or manual mode please see **Section 5.2**.

3.3.9 Pull out the sliding table and remove the transfer paper from work piece (using recommended manufacturer's guidelines).

3.4 Pressing pad assembly

This consists of the following:-

1. **Pressing Pad Base** - This fits into the well of the sliding table.
2. **Silicone Pressing Pad** - This lies on top of the pressing pad base.
3. **Pressing Pad Cover** - This is heat resistant 'Nomex' material.

N.B. The pressing pad unit must be maintained in good condition at all times and replaced whenever showing signs of wear, with particular attention being given to the pressing pad base.

A worn pressing pad will always affect the quality of the transfer printing/fusing.

Pressing pad protection – the sliding table should always be withdrawn to the full extent outside the press when not in operation to protect the pressing pad from the constant heat of the heat plate.

It is particularly important that the sliding table be withdrawn at the end of the working period as should the air supply to the press be cut off, the hot heat plate will eventually descend under its own weight and rest on the pressing pad and may damage it.

3.5 Shutting down the machine

When the transfer process is finished, there is an important matter for attention.

N.B. Do not shut down the power immediately, as the heat platen is very hot after extended machine operation. Please press the "OK" button after you finish the last heat transfer cycle, this will stop the heat platen from heating, but will allow the fan in the electronic control box to operate, thereby cooling the heat platen down. It is recommended not to turn off the power for around 20-30 minutes after you finish the transfer process to allow the fan to completely cool the platen.

Shutting down the machine (cont.)

It is suggested that the machine is not powered off for at least 1-2 hours after continuous machine operation of 6-8 hours.

To shut down in an emergency, press either of the Emergency Stop Buttons located on the left and right hand sides on the front of the sliding table frame. If the emergency stop button is actuated, it will need to be unlocked by turning it anticlockwise before the machine will run again.

3.6 Hints and tips

Transfer Printing

Extra care should always be taken to ensure that transfer paper is placed print down onto the article, as mistakes will result in the heat plate becoming soiled with ink and spoiling following work.

When transfer printing, it may be found advantageous to cover the press pad with paper to prevent strike-through of surplus ink, particularly when printing thin material as surplus print on the pressing pad cover can also strike back on the following work.

Transfer Paper/Motifs Fail to Print Out Correctly

Check:-

1. **Heat and time dwell** settings are correct.
2. **Article** having transfer applied is locked in contact between pressing pad and heat plate.
3. **Pressing pad** is in good condition, is flat and making complete contact over the whole area of the heat plate. See Pressing Pad details.

Fading of print across width

Check:-

1. **Heating elements** – that one of the 3 elements has not failed (by qualified electrician)
2. **Condition of** pressing pad unit.

“Ghosting” (Double Image) of Transfer Prints

Check:-

1. **Material being used** has been correctly heat set for transfer printing.

Hints and tips (cont.)

2. **Material being used** does not shrink during printing process, i.e. measure material before and after printing.
3. **Transfer paper** does not move after printing process upon lift off of the heat plate.
4. **If possible**, use adhesive coated paper, particularly to overcome fabric shrinkage.
5. **By pre-shrinking** of material in press before transfer printing.

4. Maintenance of the machine

For good press results it is important to keep the press surfaces clean. Wipe the surface of the heat plate with a dry non-abrasive cloth before use when the plate is cold.

When the heat plate is hot and not in use, keep in the open position away from the silicone pad.

4.1 Daily maintenance

The heat plate should be examined and cleaned on a daily basis as required.

CAUTION:

Before attempting to clean the heat plate ensure that the machine is isolated from the power supply and that the heat plate is cool.

Note:

it may take several hours for the heat plate to cool to handling temperature.

It is recommended to power off the machine for 1–2 hours after approx. 6-8 hours of continuous operation.

4.2 Weekly maintenance

CHECK:-

- a) Pressing pad cover
 - b) Silicone pressing pad
 - c) Pressing pad base
- Replace as necessary**

Note:

If print quality deteriorates it may be necessary to change the silicone pressing pad and pressing pad base.

4.3 Cleaning

First unplug the machine. Clean the outside of the machine frequently with a clean, moist cloth. This may conveniently be carried out when the machine is cold.

To prevent soiling of substrate, periodic wiping of entire exterior machine, including platens, with a clean rag is recommended. If necessary, use mineral spirits for cleaning a **cold** machine. Since mineral spirits are flammable, use precautions at all times and keep away from sparks, flames or hot heat platen.

5. Machine drawings and diagrams

On the following pages are the schematic diagrams for the Alpha Industrial Flatbed Series 7 Transfer Press.

5.1	General layout.....	Page 18
5.2	Control panel operation.....	Page 19
5.3	Control unit operation.....	Page 21
5.4	Exploded diagram and parts list.....	Page 22
5.5	Electrical diagram	Page 23
5.6	Pneumatic schematic.....	Page 24
5.7	Machine assembly.....	Page 25

5.3 Control Unit Operation

(The Heat Plate must always be in the down position before the Controller is set)

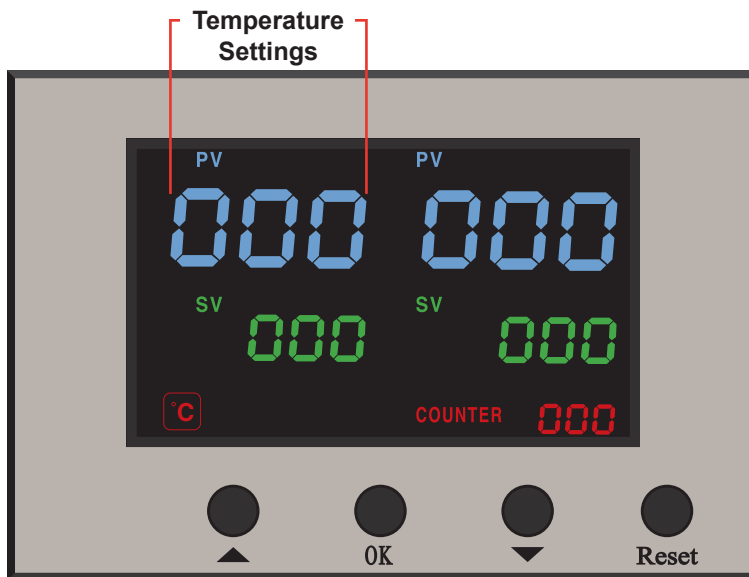

Setting Temperature

1. Switch on machine.
2. Press the 'OK' button to enter the temperature setting mode (the '°C' light will flash).
3. Using the '▼' or '▲' buttons select between '°C' or '°F'.
4. Press the 'OK' button twice to enter the temperature setting mode (the temperature settings digits and 'SV' will flash).
5. Use the '▼' or '▲' buttons to select the temperature required for the transfer material being used.
6. Press the 'OK' button to turn the 'SV' light and temperature settings digits off.

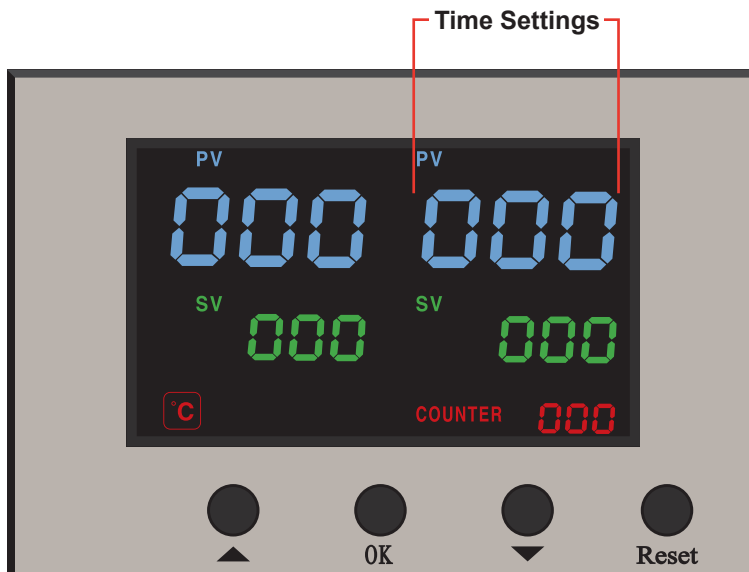

Setting Time

1. Press the 'OK' button three times to enter the time setting mode (the 'SV' and time settings lights will flash).
2. Use the '▼' or '▲' buttons to select the time required for the transfer material being used.
3. Press the 'OK' button to turn the 'SV' and time settings lights off.
4. The digital display will now show the rising temperature until the set heat is achieved. At this point a buzzer will sound to indicate that the machine has reached the set operating temperature and is ready to use.
5. **To reset the counter to zero press and hold 'Reset' button for 5 seconds.**

5.4 Exploded diagram and parts list

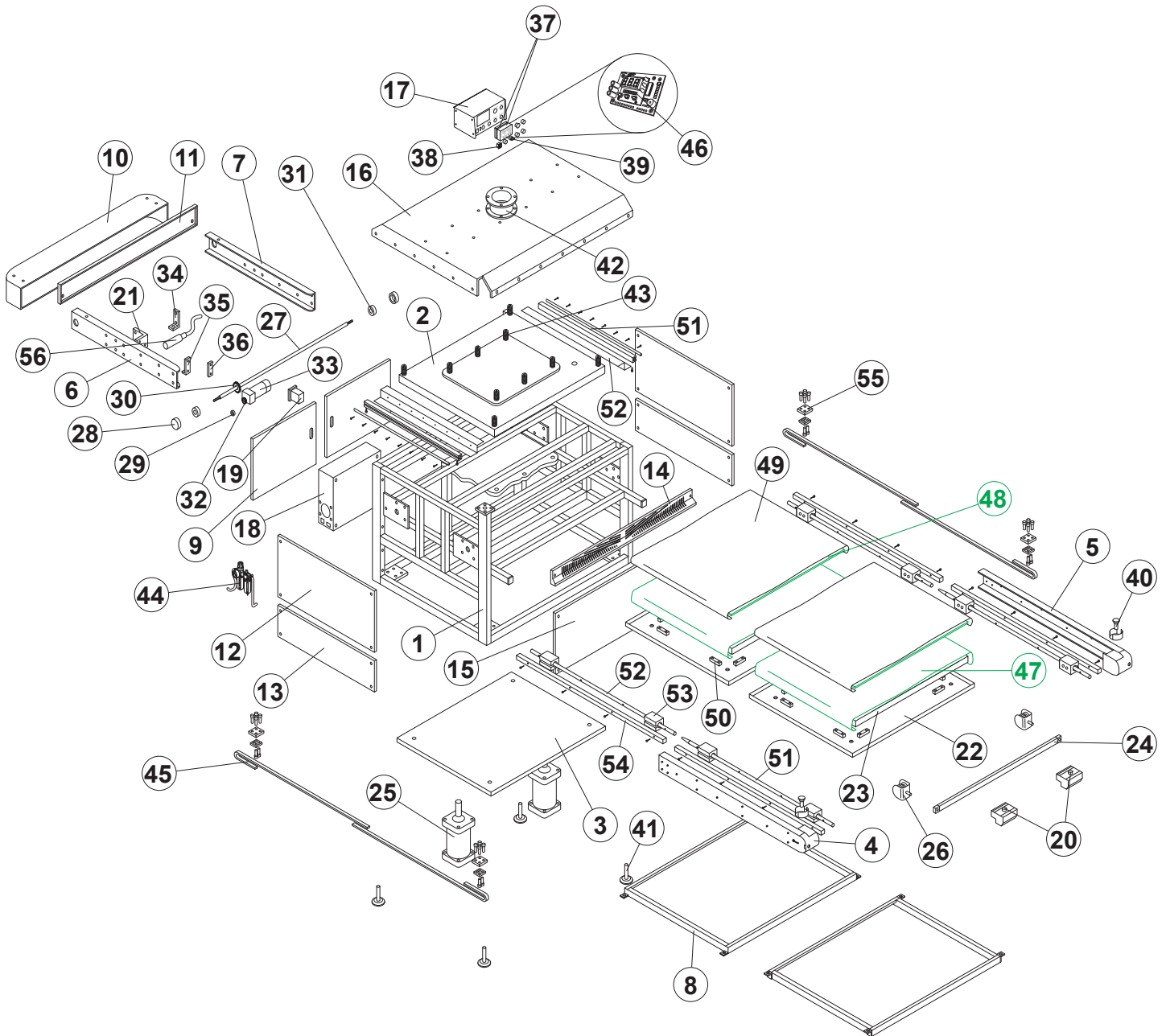

No.	Description	Qty.	Part no.	20	Start switch	6	AIPSS019	37	Controller housing (2 part)	1	EZMM/12
1	Machine frame	1	AIPSS001	21	Mounting plate for speed regulating motor	1	AIPSS020	38	Power switch	1	OMC750/7
2	Heat plate assembly	1	AIPSS002	22	Supporting plate	2	AIPSS021	39	Transfer switch	1	AIP039
3	Lift platform	1	AIPSS003	23	Silicon pad	2	AIPSS022	40	Emergency stop button	3	AIPSS037
4	Left hand guide rail	1	AIPSS004	24	Reinforcing bar	1	AIPSS023	41	Adjustable machine foot	4	AIP026
5	Right hand guide rail	1	AIPSS005	25	Air cylinder	2	AIPSS024	42	Extractor collar	1	AIPSS040
6	Rear left hand guide rail	1	AIPSS006	26	Tension regulator	2	AIPSS025	43	Compression spring	10	AIPSS041
7	Rear right hand guide rail	1	AIPSS007	27	Drive rod	1	AIPSS026	44	Air valve	1	AIP045
8	Heat plate support frame	2	AIPSS008	28	Terminal cover	2	AIPSS027	45	Synchronous belt	4	AIPSS038
9	Electric control box door	2	AIPSS009	29	6003 bearing	2	AIPSS028	46	Digital controller (2 part)	1	STEZA/16
10	Rear baffle	1	AIPSS010	30	Drive sprocket	1	AIPSS029	47	White felt (optional)	2	AIP058
11	Upper rear panel	1	AIPSS011	31	Synchronous wheel	2	AIPSS030	48	Green silicon (optional)	2	APSIL-100x120M
12	Upper side panel	2	AIPSS012	32	13 tooth sprocket	1	AIPSS031			2	APSIL-120x170L
13	Lower side panel	2	AIPSS013	33	Speed motor	1	AIPSS032	49	Nomex® Cover (100 x 120cm)	1	AIPNOMEX-100x120M
14	Front vented cover	1	AIPSS014	34	Mounting plate for proximity switch	1	AIPSS033		Nomex® Cover (120 x 170cm)	1	AIPNOMEX-120x170L
15	Front panel	1	AIPSS015	35	Mounting plate for bottom sensor switch	1	AIPSS034	50	Support blocks	16	AIPSS042
16	Machine cover	1	AIPSS016	36	Induction plate	1	AIPSS035	51	Front Linear Bearing Shaft	2	AIPSS043
17	Controller box	1	AIPSS017					52	Back Linear Bearing Shaft	2	AIPSS044
18	Main electric box	1	AIPSS018					53	Linear Bearing and Block	8	AIPSS045
19	Speed regulator	1	AIPSS039					54	Linear Bearing Shaft Mount	4	AIPSS046
								55	Belts Clamp	8	AIPSS047
								56	Proximity Switch	4	AIP056

5.5 Electrical diagram (380V three phase)

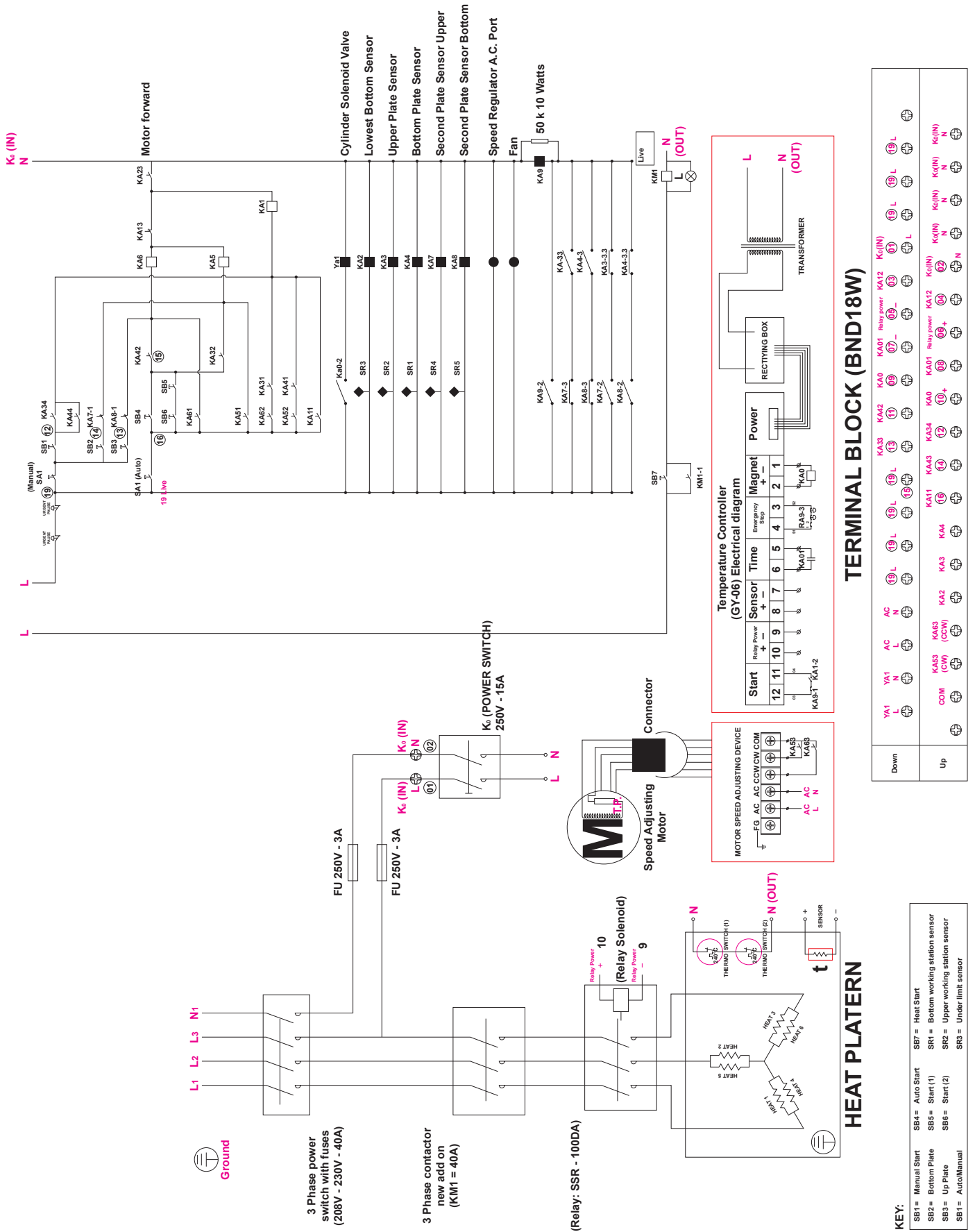

TERMINAL BLOCK (BND18W)

Down	YA1	YA1	AC	AC	KA0	KA02	KA03	KA01	Relay power	KA12	Ko(IN)	19	L	19	L	19	L	Ko(IN)	Ko(IN)	Ko(IN)	Ko(IN)	
Up	COM	KA53	KA63	KA2	KA3	KA4	KA11	KA13	KA34	KA0	KA01	Relay power	KA12	Ko(IN)	19	L	19	L	19	L	19	L

KEY:

- SB1 = Manual Start
- SB2 = Bottom Plate
- SB3 = Up Plate
- SB4 = Auto Start
- SB5 = Start(1)
- SB6 = Start(2)
- SB7 = Heat Start
- SR1 = Bottom working station sensor
- SR2 = Upper working station sensor
- SR3 = Under limit sensor

5.6 Pneumatic schematic

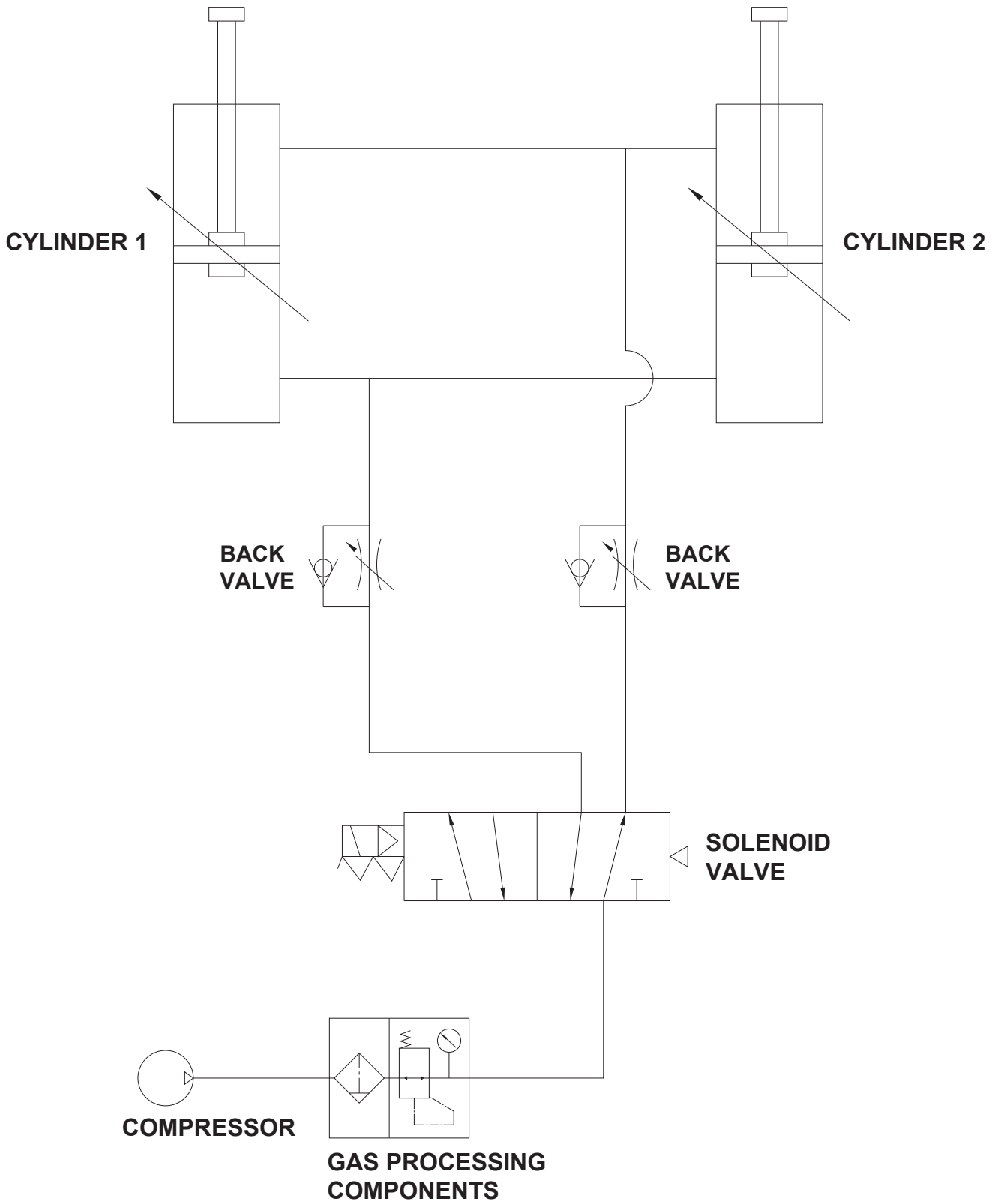

5.7 Machine assembly

1. **Connect air supply to machine to allow heat plate to rise.**
2. **Remove table from machine and store safely.**
3. **Fit the left hand and right hand table brackets (part nos.13 and 12) being careful not to trap cabling when attaching left hand table bracket.**
4. **Fit the two angled table support arms (parts no.52).**
5. **Fit the slide rail connecting boards (parts no.16) by loosely inserting the left and right hand screws (do not tighten screws yet).**
6. **Fit the two rails (part no.15).**
7. **Tighten all screws securely.**
8. **Finally place table onto slide rails (part nos.14 and 15), making sure that the bearings (parts no. 22) are securely located on slide rail tracks.**

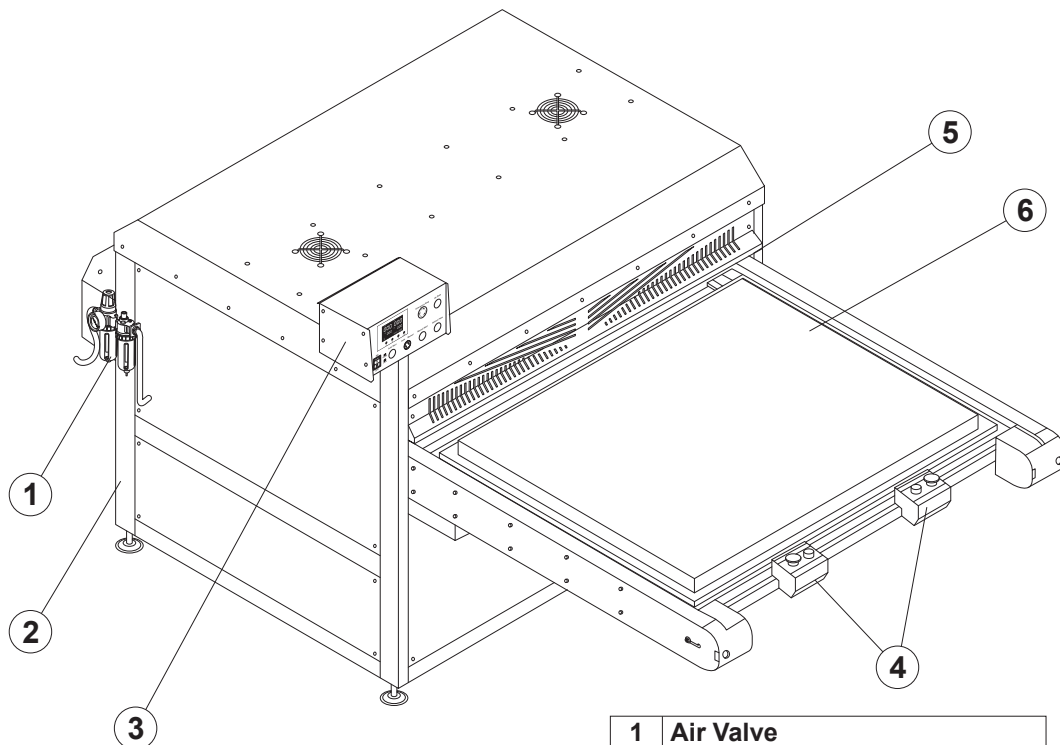

1	Air Valve
2	Machine Frame
3	Electrical Control Box
4	Emergency/ Start-up Switches
5	Upper Plate
6	Lower Plate

6. Design change

With the policy of constant improvement and/or modification to meet changing conditions, the right is reserved to change the design and/or specifications at any time without prior notification, and therefore specifications may vary and not be in accordance with this manual.

7. Guarantee (limited warranty)

A. Adkins & Sons Limited warrants that the press is free from defects in material and workmanship for a period of 12 months from the date of supply. The machine comes with a lifetime warranty on the heating element, one year warranty on parts and 90 days labour.

This warranty covers all parts to repair the defects, except when damage results from misuse or abuse, accident, alteration or negligence or when a machine has been improperly installed.

If a press covered by warranty should need to be returned to the factory for examination and repair, if on-site component replacement is not possible, A. Adkins & Sons Limited will make every effort to repair the customers press. The warranty will only be effective when A Adkins & Sons Limited authorises the original purchaser to return the machine to the factory and only when the product upon examination has proven to be defective.

Should in our opinion any part of this press be defective in materials or workmanship, it will be replaced or repaired free of charge, provided that the press has been installed and operated in the correct manner and not subjected to misuse. If A. Adkins & Sons Limited authorise a replacement press, the warranty of the replacement press shall expire on the anniversary date of the original machines invoice to the customer.

In order for this warranty to be effective, no return of machine or parts may be made without prior factory authorisation. (This will exclude any travelling and/or carriage costs which will be charged at our discretion).

This is the sole warranty given by the company; there are no warranties, which extend beyond the description on the face hereof. The seller disclaims any implied warranty of merchantability and/or any implied warranty of fitness for a particular purpose; the buyer agrees that the goods are sold "as is". A. Adkins & Sons Limited does not warrant that the functions of the press will meet the customer's requirements or expectations. The entire risk as to use, quality and performance of the press lies with the customer. (No claim of any kind shall be greater than the sale price of the product or part to which the claim is made).

In no event will A. Adkins & Sons Limited be liable for any injury, loss or damage, including loss of profits, destruction of goods or any special, incidental, consequential or indirect damages arising from the use of the press or accompanying materials. This limitation will apply even if A. Adkins & Sons Limited or its authorised agent had been advised of the possibility of such damage.

A. ADKINS & SONS LIMITED
DECLARATION OF CONFORMITY



<p>Application of Council Directives:</p> <p>Standards to which Conformity is Declared:</p>	<p>Machinery, Low Voltage. E.M.C.</p> <p><u>BS EN ISO 12100:2010</u> - Safety of machinery: Basic Technology, Principles of Design. <u>BS EN 6024-1:2006+A1:2009</u> - Safety of machinery: Electrical Equipment of Machines. <u>BS EN 60529:1992-A2:2013</u> - Degree of protection provided by enclosures. <u>BS EN ISO 13850:2015</u> - Safety of Machinery: Emergency Stops. <u>BS EN ISO 141211:2007</u> - Safety of Machinery: Principles for Risk Assessment. <u>BS EN 55011:2016+A1:2017</u> - Class A Group 2 Equipment - EMC Emissions. <u>BS EN ISO 61000-6-4:2007+A1:2011</u> - EMC Conducted Emissions. <u>BS EN ISO 61000-6-2:2005</u> - EMC Immunity.</p>
<p>Manufacturer's Name:</p>	<p><u>A. Adkins & Sons Limited</u></p>
<p>Manufacturer's Address:</p>	<p>High Cross, 18 Lancaster Road, Hinckley, Leicester, LE10 0AW, United Kingdom.</p>
<p>Type of Equipment:</p>	<p>Alpha Industrial Flatbed Series 7 Heat Press</p>
<p>Standards Compliance:</p>	
<p>Model Number:</p>	<p>.....</p>
<p>Serial Number:</p>	<p>.....</p>
<p>Year of Manufacture:</p>	<p>.....</p>

I, the undersigned, hereby declare that the equipment specified above conforms to the above directives and standards.

Place: Hinckley, United Kingdom

Signature: 

Date:

Full Name: Marie McMahon
 Position: General Manager